

MP3 DIGITAL AUDIO FM TUNER

Plays Windows Media REC VOICE recorder

Instruction Manual

PORTABLE STORAGE DEVICE & MULTI - CODEC JUKE BOX Model iHP-100

iRiver
Model iHP-100



Firmware Upgradable

Thank you for your purchase.
Please read this manual carefully
before using your new player.

iRiver Limited
<http://www.iRiverAmerica.com>

iRiver Limited
<http://www.iRiverAmerica.com>

THIS DEVICE COMPLIES WITH PART 15 OF THE FCC RULES. OPERATION IS SUBJECT TO THE FOLLOWING TWO CONDITIONS:
(1) THIS DEVICE MAY NOT CAUSE HARMFUL INTERFERENCE, AND
(2) THIS DEVICE MUST ACCEPT ANY INTERFERENCE, RECEIVED, INCLUDING INTERFERENCE THAT MAY CAUSE UNDESIRE OPERATION.

Note : This equipment has been tested and found to comply with the limits for a Class B digital device, pursuant to part 15 of the FCC Rules. These limits are designed to provide reasonable protection against harmful interference in a residential installation.

This equipment generates, uses and can radiate radio frequency energy and, if not installed and used in accordance with the instructions, may cause harmful interference to radio communications. However, there is no guarantee that interference will not occur in a particular installation. If this equipment does cause harmful interference to radio or television reception, which can be determined by turning the equipment off and on, the user is encouraged to try to correct the interference by one or more of the following measures :

- Reorient or relocate the receiving antenna.
- Increase the separation between the equipment and receiver.
- Connect the equipment into an outlet on a circuit different from that to which the receiver is connected.
- Consult the dealer or an experienced radio/TV technician for help.

NOTE: THE MANUFACTURER IS NOT RESPONSIBLE FOR ANY RADIO OR TV INTERFERENCE CAUSED BY UNAUTHORIZED MODIFICATIONS TO THIS EQUIPMENT. SUCH MODIFICATIONS COULD VOID THE USER'S AUTHORITY TO OPERATE THE EQUIPMENT.

- **Portable Storage Device**
iHP-100 can be used as a storage device.
- **USB 2.0 is supported**
iHP-100 supports USB 2.0 with maximum transfer speed of 480 Mbit/Sec.
- **Multi-Codec Player**
Supports MP3, WMA, ASF, and WAV formats as a multi-Codec player.
iHP-100 supports WAV type of 11/22/44KHz, 16bit, Mono/Stereo.
- **Firmware Upgrade**
Provides the latest updated features via firmware upgrade.
Player features such as add on, modification, and continuous improvement of the player are always provided.
- **Graphic LCD supporting Multiple Languages**
iHP-100 comes with a graphic LCD which can support multiple languages, including: English, French, Spanish, German, Italian, other alphabet-oriented fonts, Korean, Japanese (Katakana, Hiragana, Kanji), Chinese (Traditional, Simplified) and others. A total of 38 languages are supported.
- **FM Tuner**
Auto scanning and frequency memory function make it easy for you to enjoy listening to the FM Radio.
- **This player supports 6 Equalizer Patterns.**
Normal, Rock, Jazz, Classic, Ultra Bass, User EQ
- **Easy Navigation**
The simple navigation with tree configuration makes it easy to find or save any song.
- **The player can recognize up to 1000 folders and 5000 files.**
- **Graphic User Interface Menu Support**
- **Voice recording and recording (Line-In/Optical In) from an external audio equipment is supported.**
When voice recording, recording level is automatically controlled at voice recording mode.
- **Line-Out / Optical-Out function is supported**

- URL : <http://www.iRiverAmerica.com>
- Provides information on our company, products, and email addresses for support.
- Unique feature of "Firmware (system software) Upgrade" is available for download on our site. The Firmware Upgrade provides new features as well as enhancements to current features.
- Register your iRiver product online so that our Customer Service is enabled to provide support as efficiently as possible.
- Contents described in this manual may be changed to improve or any specification without notice.

The information, artwork, text, video, audio, pictures, software and other intellectual property are protected by copyright and international laws.

You may not reproduce, distribute, publicly perform, publicly display, modify or create derivative works of the intellectual property, unless authorized by the appropriate copyright owner(s). iRiver does not encourage any of our customers to use copy-righted Intellectual property illegally by using this product.

iRiver Limited does not assume any responsibility for errors or omissions in this document or make any commitment to update the information contained herein. iRiver is a registered trademark of iRiver Limited in the Republic of Korea and/or other countries and is used under license. All other brand and product names are trademarks of their respective companies or organization. All other product names may be trademarks of the companies with which they are associated.

©1999~2003 iRiver Limited, All rights reserved.

Microsoft Windows Media and the Windows logo are trademarks or registered trademarks of Microsoft Corporation in the United States and /or other countries.

1. Locating the Controls

Front View, Side View.....	5
Up/ Down Side, LCD Window.....	6
Remote Control.....	7

2. Getting started

Using AC POWER ADAPTER.....	8
Software Installation.....	9
Connecting the iHP-100 to the Host PC.....	10
Installing the iHP-100 Device Driver.....	11
Using as a Portable Storage Device.....	12
Disconnecting the iHP-100 to the Host PC.....	13
Listening to Music.....	14~15
Basic Operation.....	16~19

3. Useful Features

Navigation Mode / Menu / Mode.....	19
Playback Mode.....	20
Navigation.....	21~23
Upgrading DB.....	24
Adding DB.....	25
Operating the FM Tuner.....	26~28
Recording.....	29~31
Playback Mode.....	32
EQ.....	33
Menu.....	34~42
Firmware Upgrade.....	43

4. Additional Information

Reference.....	44
Precautions.....	45
Trouble Shooting.....	46
Accessories.....	47
Product Specifications.....	48
Regulatory information.....	49

FRONT VIEW

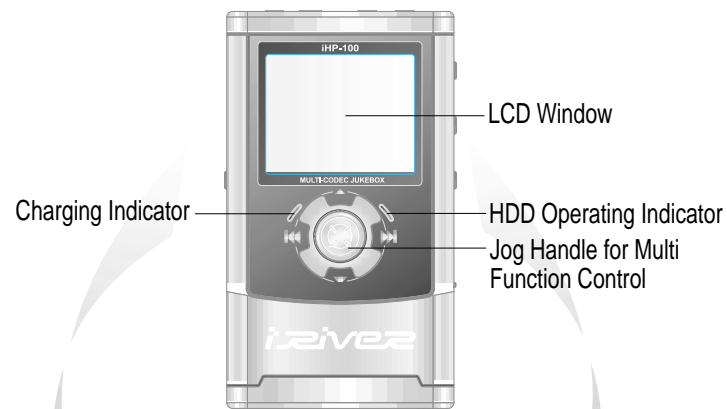

SIDE VIEW

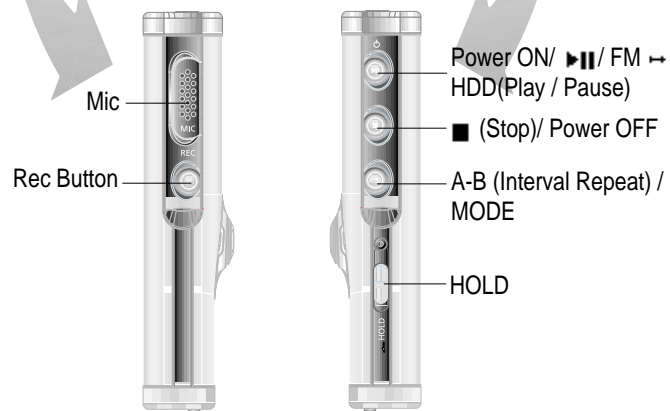

UP/ DOWN SIDE

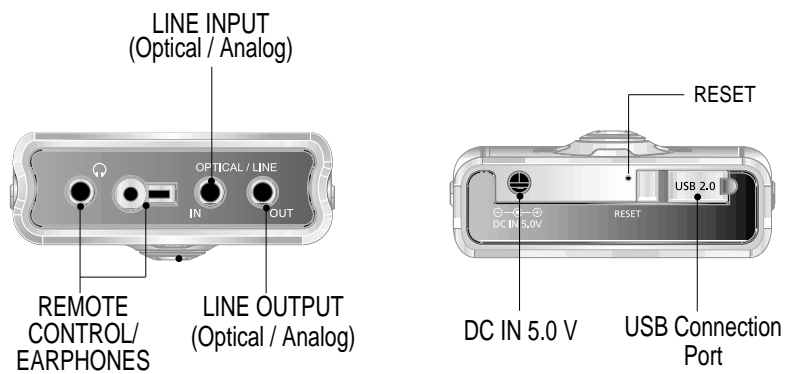

LCD Window

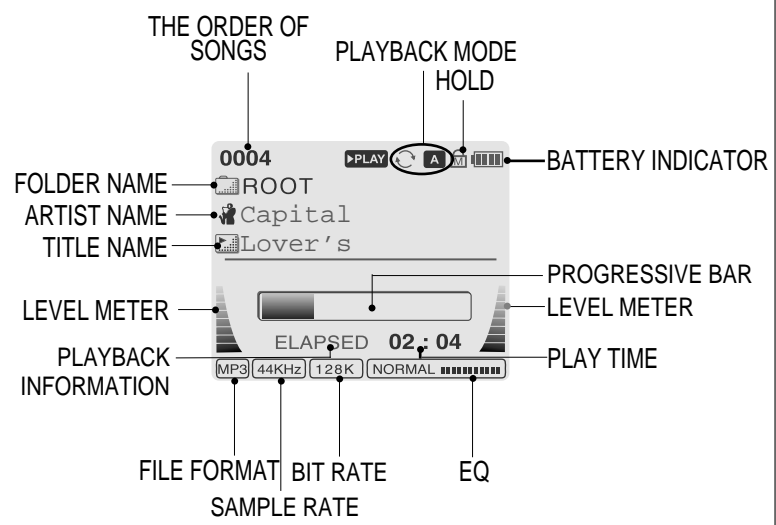

Remote Control

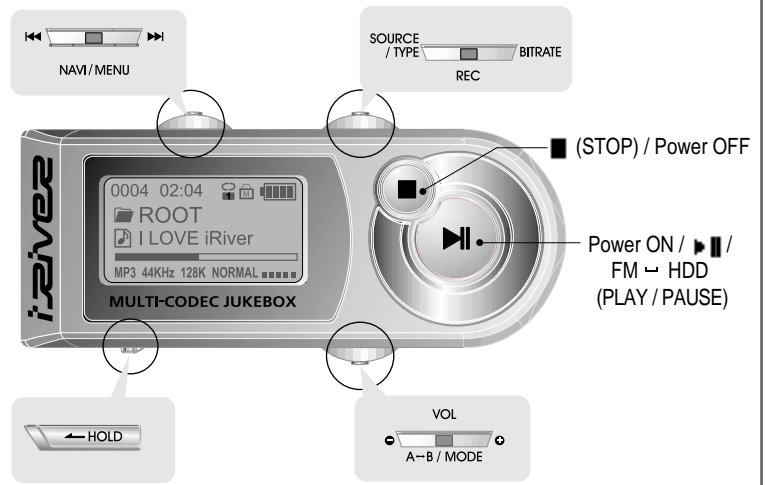

LCD Window (Remote Control)

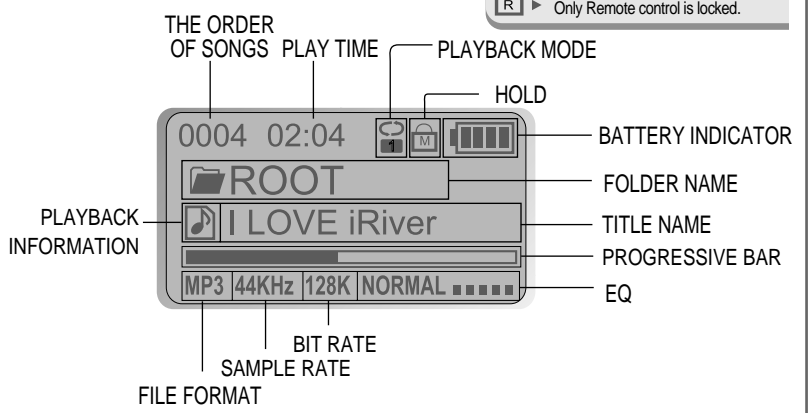

Using AC POWER ADAPTER

- 1 Use only the AC Power Adapter supplied with the player.
- 2 Connect the adapter to the 5.0V DC jack on the player and into an AC outlet.

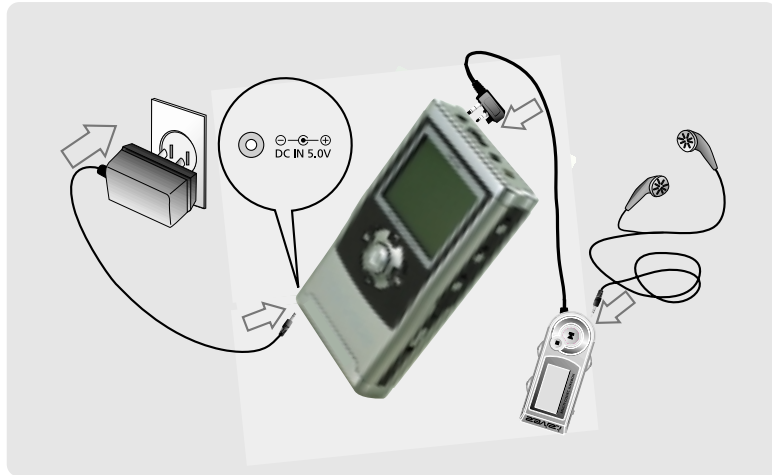

Recharging Method

- Rechargeable function can automatically be activated while the AC adapter is connected to the player.
- When fully charged, charge indicator light turns off.

Charging : Approx. 3 hours (At full discharge)

Discharging (Playback time) : Approx. 16 hours (At full charge)

To install "Program"

Windows 2000 and Windows XP have the program to support USB 2.0 Storage Device, and you can use this player without any program installation. Install the iRiver iHP Manager to use the Database Function. Windows 98 SE, ME, require the iRiver iHP Manager to be installed.

- 1 Insert the Installation CD into the CD-ROM drive. The following screen appears after inserting the CD.



- 2 Click "OK" to install the installation program.

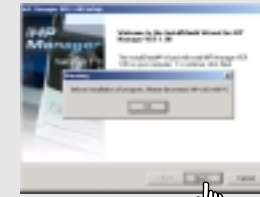

- 3 Enter user information, click "Next".



- 4 Select installation folder, click "Next".

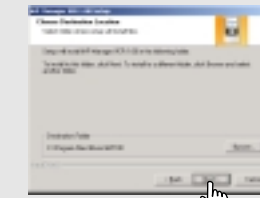

- 5 Select installation type (Typical, Minimal, or Custom), click "Next".

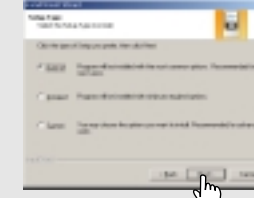

- 6 Installation is progressing.

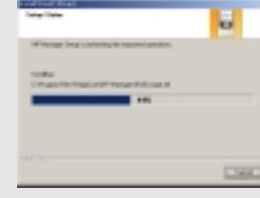

- Click "Finish".
The installation is completed.



To connect the iHP-100 to the Host PC

- Click to turn on the player.



- Connect the USB cable to the player and the PC to recognize the correct information after Host PC is operated.

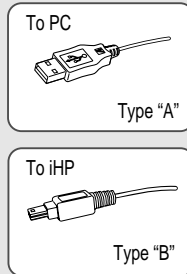
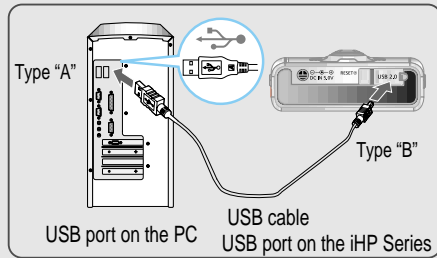

- Windows XP and Windows 2000 will display a "Device Attached" icon. Windows may ask to install a driver for the iHP driver. Please follow the provided driver installation guide on the following page.



- Once installed, open Windows Explorer and an additional drive should be listed called 'iHP-100'.

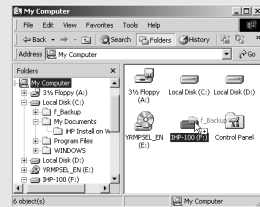

To install the iHP-100 Device Driver

This processing must be done after installing the iHP-100 Manager Program.

- If the player is recognized on your PC, "Add New Hardware Wizard" is activated. Click "Next".
- Chose "Search for the best driver for your device (Recommended)." Click Next.



- Place a checkmark next to "Specify a location" and click Browse.



- Locate the following path on your computer. C:\Program Files\iRiver\iHP100\drivers, click "OK".

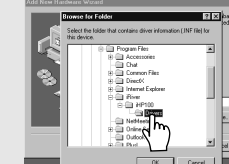

- Once the path has been located, Click "Next".



- Click "Next"



- Click "Finish"
Completed the installation of "Device Driver".



To use as a portable storage device

If the player is not connected to the host PC, connect it to the host PC. (Refer to page 10)

- 1 Check the icon of the player on the PC window and confirm whether the player is added as a new drive in Windows Explorer.

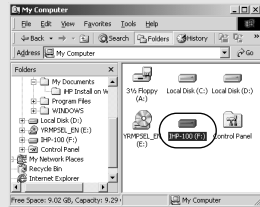

- 2 Click and Drag files from the PC to the iHP player.

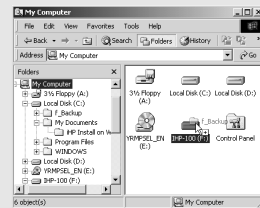

- 3 To delete files or folders from the iHP-100, select the files (folders) to be deleted and press "Delete" on the keyboard. Click "Yes" when asked to confirm the delete.

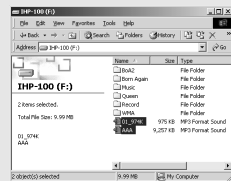

The iHP-100 operates just like an additional hard drive in Windows Explorer. Files can be copied, deleted, etc.



Note

When the iHP-100 is attached to a computer for an extended period of time, be sure to plug in the AC adapter. Low batteries can prevent the proper functioning of the iHP-100.

To disconnect the player from the Host PC

- 1 Click the 'Safely Remove Hardware' icon in the System Tray.



- 2 Click "Stop iRiver iHP-100-Driver(X)" or "Safely Remove TOSHIBA MK1_3GAL USB Disk - Drive(X)". (Where X is the drive letter assigned to the iHP-100)



- 3 Click "OK" after confirming the "Safe To Remove Hardware" message.



- 4 Disconnect the USB cable between the iHP-100 and host PC.

1 Connect the headphones and remote control as shown below.

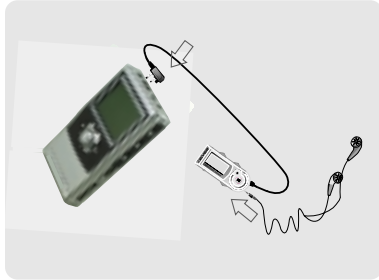

2 Put the HOLD switch to "OFF".

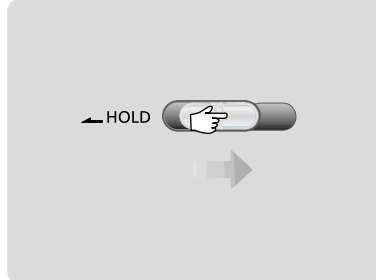

3 Press the PLAY/STOP button to turn on the player. Press it again to play.



4 To select music
 ◀◀ : To select previous track
 ▶▶ : To select next track

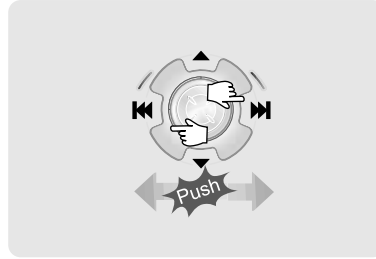

5 To adjust the volume
 ▲|+| : To increase volume
 ▼|-| : To decrease volume

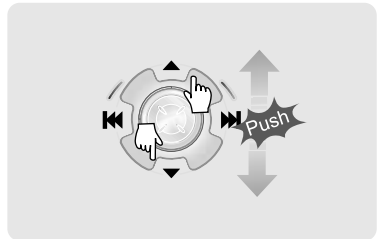

NOTE
 - When "Hold" is ON, the buttons on the player will not function.
 - In case of stop status of the player or standby status of Voice recording, the player automatically turns off according to the setting of "STOP POWER OFF" on the MENU. (Refer to page 39)

■ Power ON



■ File playback ↔ FM receiving



■ To play / Pause



■ To fast forward



■ To stop



■ To fast reverse



■ To play next track



■ To play previous track



■ To turn off the player



Tip

File Format displayed as below

MP3	▶ MP3	WMA	▶ WMA
ASF	▶ ASF	WAV	▶ WAV



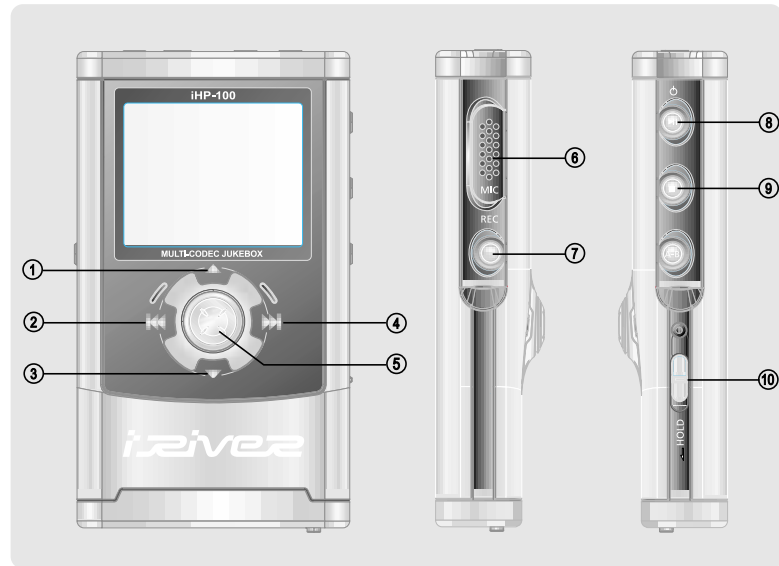

● To activate Navigation



1. To increase volume.
2. To select the previous track or FM station.
3. To increase volume.
4. To select the next track or FM station.
5. To select NAVI/MENU function.
6. Internal Microphone
7. To change record standby mode or start recording.
8. To start or pause playback to change FM → HDD.
9. To stop playback or recording or turn off.
10. HOLD: Enable or disable HOLD function. Buttons do not work when HOLD is enabled.

● To activate Menu



Basic Operation



■ To adjust the volume

Press + on volume button to increase volume and press - on button to decrease volume.



File playback → FM receiving



(Refer to page 26)

Selecting FM Mode when listening FM Stereo → Mono



■ To Record

[Record standby]



[To select source to record]

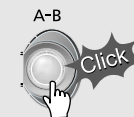

[To start recording]



[To select Bitrate Type]

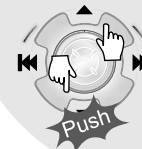

[To select File Type]

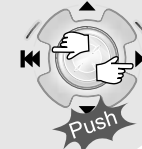

[To stop recording / Standby for recording]



NAVIGATION

■ Press NAVI/MENU button and find the desired track by pressing the VOL + or VOL - button, |◀▶| or ▶▶|, NAVI/MENU button.

■ There are two methods using ID3 Tag and PATH/NAME of File on NAVIGATION. Refer to page 21-23 for details.

The remote control operates every function by using 5 buttons.

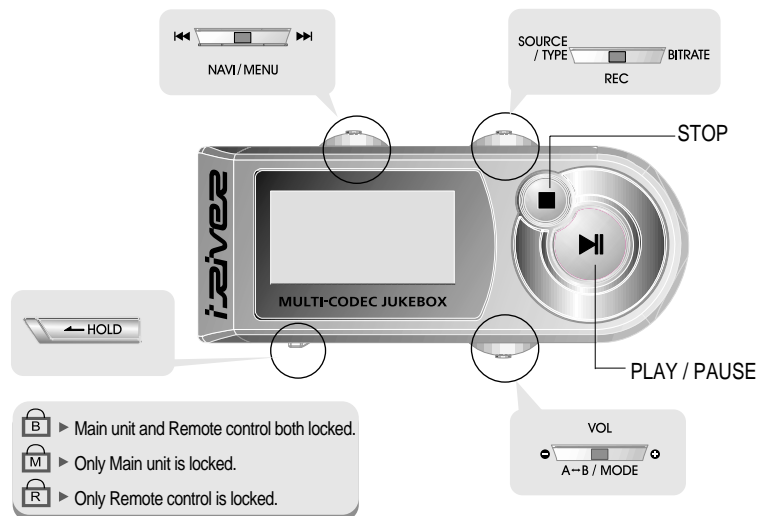

Basic Operation Function

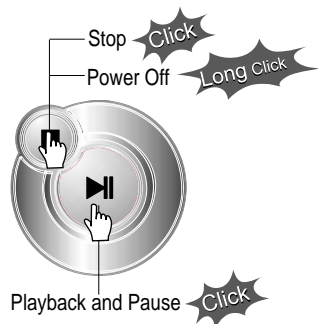

Navigation Operation

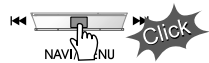

To listen to the next track, please push the jog switch to the right.

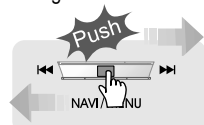

To listen to the previous track, please push the jog switch to the left.

Menu Operation



Basic Operation Function

Volume Control

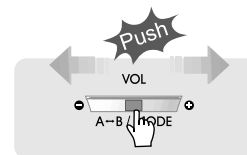

Slide jog lever to the right to increase volume or to the left to decrease volume.

Changing Mode

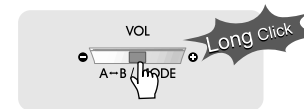

HDD - FM Changing



NAVIGATION

Press the Navi/Menu jog lever with a short click and find the desired track by pressing **⏮** or **⏭**. To play the track, press Navi/Menu with a short click.

To move to upper folder, press the STOP button. If there is no upper folder, pressing the Stop button will exit the NAVIGATION mode.

MENU

Long press of NAVI/MENU will enter the MENU.

- ⏮ Scrolling between menus : Press **⏮** and **⏭**.
- ⏮ Select Function: press Navi/Menu button.
- ⏮ Exit: Press the stop button.

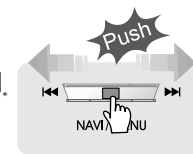

MODE

While an audio file is playing, press and hold the A-B/MODE button to activate playback modes (Repeat, Shuffle, etc.).

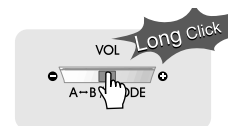

Interval Repeat

Play selected interval repeatedly while playing.

Press A-B button once to select the beginning <A> Point.

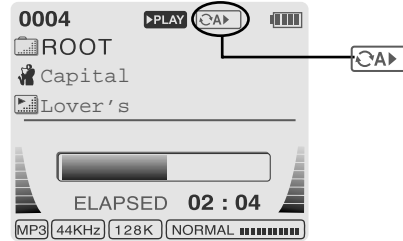

Press A-B button again to select the ending Point.

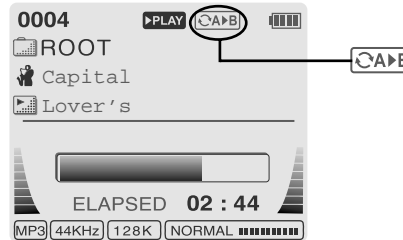

● A-B interval will be repeated.

Navigation mode is useful for quickly searching your files by using ID3 tag information and file name.

In case the database file is damaged or deleted, the Navigation function will use the normal "File Tree" method of searching.

1. Navigation using File Tree

- 1 Press the NAVI/MENU button to display the list of audio tracks. The current track will also be displayed.

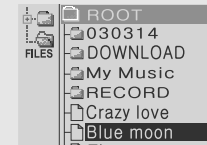

- 2 Push the NAVI/MENU handle toward ▲ or ▼ to select a track or folder to play.

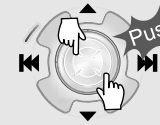

- 3 Press the NAVI/MENU button to play the selected track or display the contents of a folder.

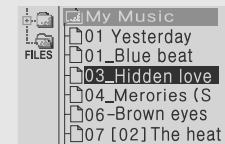
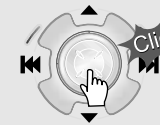

- Once you select a folder, choose the song you wish to listen to and press the NAVI/MENU button.
- Push the NAVI/MENU handle toward ◀◀ to go the upper folder or the previous menu.

2. Navigation using Music Information

Navigation mode is useful for quickly searching your files by using ID3 tag information and file name.

In case the database file is damaged or deleted, the Navigation function will use the normal "File Tree" method of searching.

- 1 Press the NAVI/MENU button.
The function selection graphic displays on the LCD.



- 2 Push the NAVI/MENU handle toward or to select the searching function.

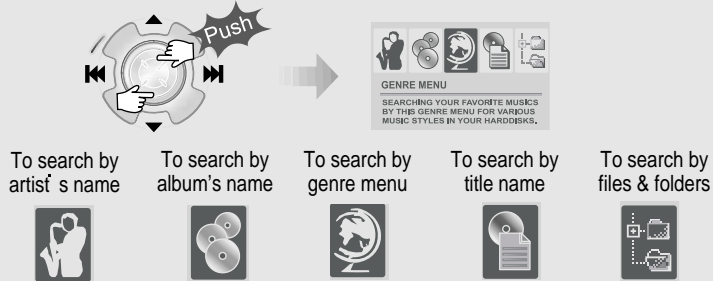

- 3 Press NAVI/MENU to display the details of the selected searching method.

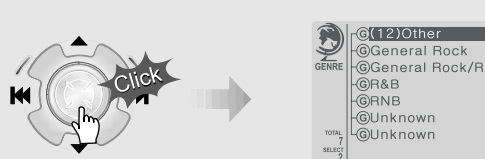

- 4 Press the NAVI/MENU handle toward or to select searching condition.



- 5 Press the NAVI/MENU button to display the detail of the selected search condition.



- If the selected search condition does not have any details, playback of matching tracks will begin immediately.



- When you select "Select All", all tracks matching the selected condition are played and (Indicating List Repeat Mode) is displayed.
- To cancel List Repeat Mode, press STOP button at the stop mode.
- Repeat 4 ~ 5 steps to search for other tracks.
- Push to go back the previous step.

To update DB

This allows you to reconstitute DB for MP3 files based on ID3 Tag information. Artist, Album, Genre, etc.

If the iRivNavi.iDB file is damaged or deleted, files can no longer be searched by ID3 Tag information. The file can be restored from the PC.

- 1 Connect the player to the host PC. (Refer to "Connecting the iHP-100 to the Host PC", page 10)

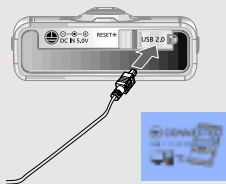

- 2 Open Windows Explorer and select the iHP-100 drive.

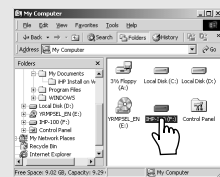

- 3 Right click on the iHP-100.

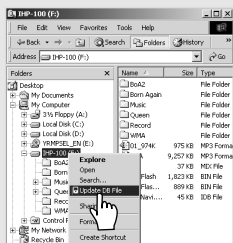

- 4 Select "DB File update" to activate DB File update.

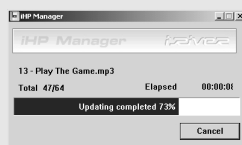

- 5 Click "OK".

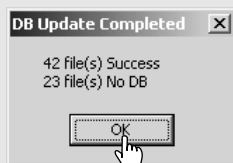

- 6 After disconnecting the player from the host PC, you can use the Navigation function to search for songs using ID3 Tag information. (Refer to "Disconnecting the player from the Host PC", page 13.)



To add DB

You can add DB file for MP3 files based on ID3 Tag information by using the host PC.

- 1 Connect the player to the host PC. (Refer to "Connecting the iHP-100 to the Host PC", page 10)

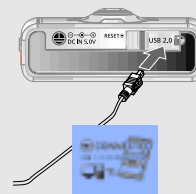

- 2 After activating the explorer on the PC, select iHP-100 driver.

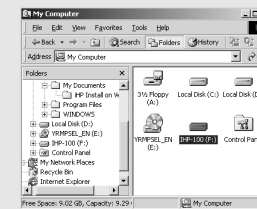

- 3 Click the right button of mouse after selecting MP3 files or Folders to add to DB.

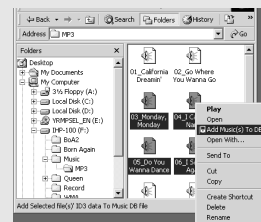

- 4 Select "Add Music(s) to DB" to activate this function.

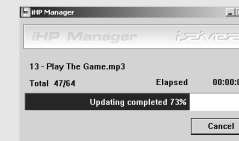

- 5 ID3 Tag information of the selected files are added to DB. In case DB file is not, new DB file (iRivNavi.iDB) is created.

- 6 After disconnecting the player from the host PC, you can search the added music by using ID3 Tag. (Refer to "Disconnecting the player from the Host PC", page 13.)



OPERATING THE FM TUNER

- While playing an Audio File, Press and hold the PLAY/PAUSE button.



The FM function picture displays on the LCD. ▶

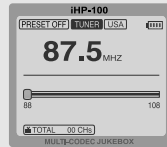

- Push the ◀◀ or ▶▶ button to select FM frequency.

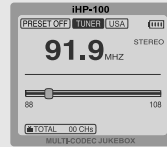
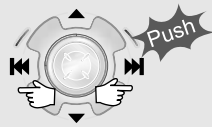

- Press the STEREO/PLAY/PAUSE button to select Stereo/Mono.



Selecting Frequency

- To change frequency, push the ◀◀ or ▶▶ switch to the left or the right.



- Auto Scan function: To select a station to store, press the NAVI/MENU button to exit Preset mode and find a station by using ◀◀ or ▶▶.



- PRESET Mode : To select a station saved in memory, press the NAVI/MENU button to enter Preset mode. Select a stored station by using the ◀◀ or ▶▶ switch.



Memory Function (Save stations manually)

- Select a station by pushing the ◀◀ or ▶▶ switch to the left or the right.



Push ◀◀ or ▶▶ and select the desired station to save the station to.

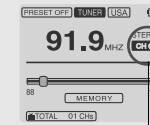

again



Save complete

Select CH02



will exit the memory function without saving.

- Up to 20 stations can be stored.

Auto Memory Function (Save stations automatically)

Automatically select station and save them in sequential order.

- Press the NAVI/MENU button to exit the Preset mode.

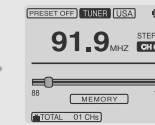

- Press and hold the A-B/MODE button.

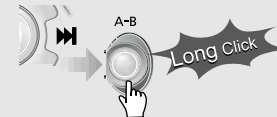

- Up to 20 stations will be stored in channels 1~20 automatically.

▶ **Note:** The Auto Memory Function may not function well in weak transmission areas.

Memory delete function (Delete saved channels)

- 1 Select the channel to be deleted at preset mode.
- 2 Press and hold the memory button.



- The next channel will appear when channel deletion is completed.
Push the MEMORY button if you want to delete the next channel also.

- ▶ FM Tuner reception may vary in different areas.
- ▶ While in Preset mode, Auto Scan and Auto Memory functions are not available.
- ▶ When the player does not have any preset channels, EMPTY will be blinking at preset mode.

Connecting the player to external audio equipment

Connect the stereo cable to the LINE IN jack on the iHP-100 and to the LINE OUT or Headphone jack of an external audio device.

If the external audio device has an Optical output, connect an Optical cable to the Optical Out jack on the external device and to the Optical In jack on the iHP-100.



Recording

- 1 Press the REC button to activate recording standby mode.



- 2 Press A-B/MODE button or push the REC switch toward SOURCE/TYPE to select the source to record
 - To record voice : MICROPHONE
 - To record from an external audio device with an Optical Out: OPTICAL.
 - To record from an external audio device with a standard Line Out or Headphone jack: LINE-IN

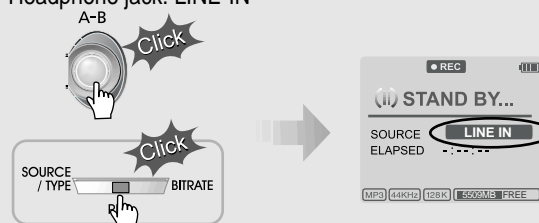

- 3 Push the MENU/NAVI handle toward [] or [], or push the REC button on the remote control toward SOURCE/TYPE to select FILE TYPE to save.

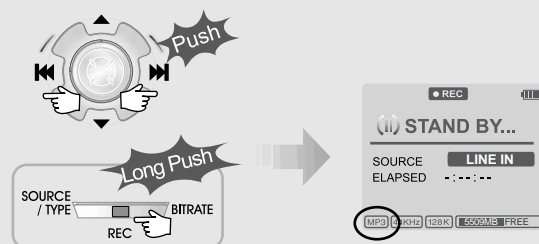

4 Push the MENU/NAVI handle toward \blacktriangle or \blacktriangledown , or push the REC button on the remote control toward BITRATE to select BITRATE TYPE to set recording quality.

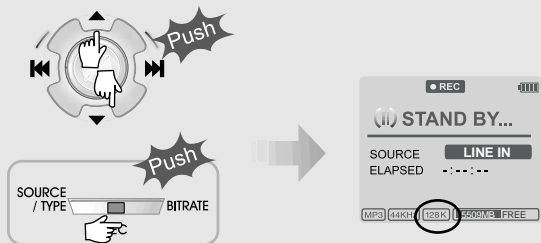

5 Push the REC button to start recording. When recording from an external audio device, be sure to start the playback on that device when recording on to the iHP-100.



NOTE Volume level can not be controlled on the iHP-100 while recording from an external device.

6 While recording, press \blacksquare (STOP/PWR OFF) to stop recording and switch to recording standby mode. Press the REC button again to begin recording to a new file.



■ Press the REC button to pause recording. And press the REC button again to restart FM recording.

To pause recording

■ During FM recording, press REC button to pause recording, press REC button again to start recording.



To stop recording

■ At recording standby mode, press and hold $\blacktriangleright\blacktriangleright$ button to go previous mode.

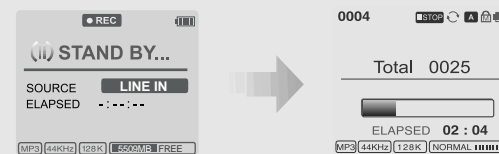

■ Pressing REC during FM reception will begin recording. There is no standby mode for FM recording.

■ Recorded files are stored in folders matching the source name from where the audio was recorded.

- Line In : ROOT\RECORD\AUDIO\AUDIOXXX.MP3(WAV)
- Mic In : ROOT\RECORD\VOICE\VOICEXXX.MP3(WAV)

■ Recording is automatically stopped if:

- The iHP-100's memory is full.
- when the recorded MP3 file size is over 195MB
- when the recorded WAV file size is over 795MB
- The recorded time is longer than 5 hours.
- The battery is low.

To play the recorded file

Press $\blacktriangleright\blacktriangleright$ button to play the recorded file at the recording standby mode.



The iHP-100 has various playback modes. Please refer to the function controls (see page 40 for details) for user-defined configurations.

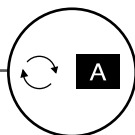

When the A-B/MODE button is pushed, the playback mode changes and an icon indicating the mode is displayed.

REPEAT

	Play a single track repeatedly. Press or to play the previous or next track.
	Play all tracks in the folder and stop.
	Play all tracks in the folder repeatedly.
	Play all tracks in the player repeatedly.

SHUFFLE

SFL	Randomly play all tracks in the player and stop.
SFL	Play a single track repeatedly. Press or to switch to a new random track.
SFL	Randomly play all tracks in the folder and stop. Press or to switch to a new random folder.
SFL	Randomly play all tracks in the folder repeatedly.
SFL	Randomly play all tracks in the player repeatedly.

INTRO

	INTRO: Play beginning 10 seconds of each track in sequential order. INTRO HIGHLIGHT: Plays 10 seconds from 1 minute into each track in sequential order. You can set this function in the MENU function.
--	---

EQ

- You can change the EQ to match your music style.
- Normal / Rock / Jazz / Classic / Ultra Bass / User EQ
- You can set the EQ function by using Function Menu. Refer to page 41.

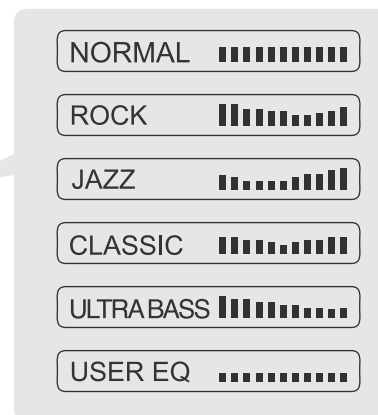
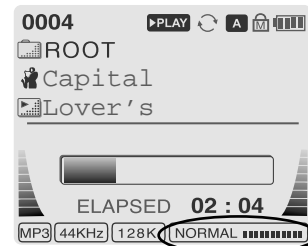

Configuration



Function Control is subject to change with different firmware versions. Users can configure their own settings.

General

- ☐ Beep Volume
- ☐ Resume
- ☐ Fade In
- ☐ Language
- ☐ Tuner Region
- ☐ Load Default
- ☐ Firmware Upgrade
- ☐ DB Scan

Display

- ☐ Back Light (Battery)
- ☐ Back Light (Adapter)
- ☐ LCD Contrast(Main)
- ☐ LCD Contrast(Remote)
- ☐ Tag Information
- ☐ Time

Timer

- ☐ Sleep Timer
- ☐ Stop Power Off

Control

- ☐ Scan Speed
- ☐ Scroll Type
- ☐ Optical Out

Mode

- ☐ Repeat
- ☐ Shuffle
- ☐ Intro

Sound

- ☐ Sound Balance
- ☐ EQ
- ☐ Bass Boost
- ☐ Treble Boost

Record

- ☐ Record Type
- ☐ Bitrate
- ☐ AGC

Menu Operation

1 Press and hold the NAVI/MENU button to display the menu system. It is composed of 7 main menus with sub-menus.

MAIN MENU

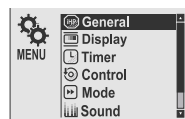

SUB MENU

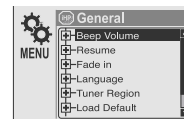

Window for SUB MENU SETTING

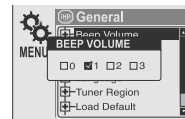

2 When you select a sub menu, you can set your preference to be displayed.

Scroll between Menu

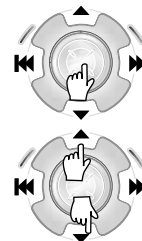

Press and hold the NAVI/MENU button to display the main menus. Push volume **▲**, **▼** to scroll between main menus, press the NAVI/MENU button to select sub menu.

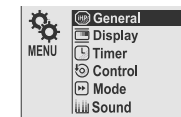

From Main Menu to Sub Menu

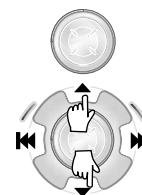

Use the **▲**, **▼** to select a sub menu, push the NAVI/MENU button to display the contents of that sub menu.

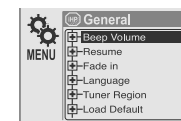

Change Settings by user



Use the **◀▶**, **▶▶** or **▲**, **▼** to change the settings. Push NAVI/MENU to save the setting.

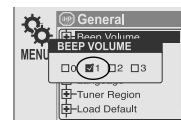

Exit Sub Menu

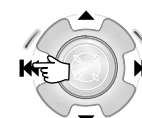

Press **◀▶** to display the initial setting menu.

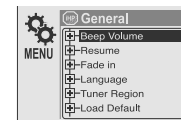

Exit Main Menu

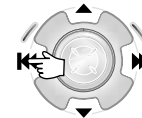

Press **◀▶** at the initial setting menu to exit Function Control Mode.

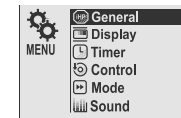

GENERAL

■ BEEP VOLUME

Set beep volume level to 0 / 1 / 2 / 3 step.

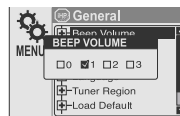

■ RESUME

When ON, player resumes to previous place in song after STOP or Power OFF.

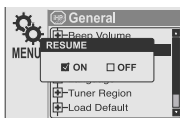

■ FADE IN

When activated, volume increases gradually at playback mode to prevent sudden loudness.

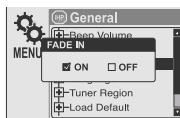

■ LANGUAGE (Supports 38 languages)

Song title and ID3 tag information is dependent on the version of the PC operating system that was used to create it. (For example, if a MP3 file is created in a Korean version of Windows, the language setting should be Korean for proper title display)



■ TUNER REGION

You can set the FM frequency and step according to your area.

Set them to fit your region to receive FM Radio.

If tuner region is newly set, the old preset stations is deleted.

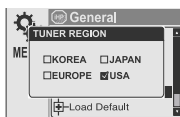

■ LOAD DEFAULT VALUE

Initialize all settings to original factory setting.

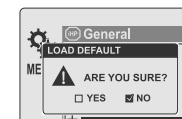

■ FIRMWARE UPGRADE

You can upgrade the player's Firmware. Refer to page 43 for details.



■ DB SCAN

Turn the Navigation to search by using ID3 Tag on or off.



When you select "YES" on the DB SCAN, it takes several seconds until power is on according to the quantity of files stored on the player.

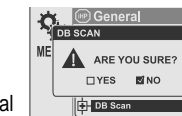

DISPLAY

■ BACK LIGHT (Battery)

You can adjust the time that the Backlight stays on while the player is operated using the battery built in the player.

Adjust Back Light by OFF / 3 sec / 5 sec / 10 sec.

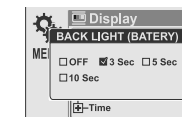

■ BACK LIGHT (Adapter)

You can adjust the time that the Backlight stays on while the player is operated using AC adapter.

Adjust Back Light by OFF / 3 sec / 5 sec / 10 sec / Always. If Always is selected, backlight is always on.

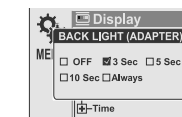

- **LCD CONTRAST (Main)**
Adjust LCD contrast of the player.

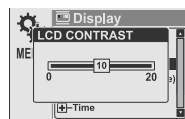

- **LCD CONTRAST (Remote)**
Adjust LCD contrast of remote control.

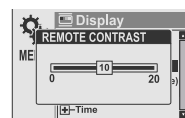

- **TAG INFORMATION**

ON : Displays track with ID3 tag information and you can change the configuration of Tag information.
OFF : Displays track with file name.

The change will take affect when the next track is played.



- **TIME**

Normal : display elapsed time.
Remain : display remaining time.

Note : In case of VBR MP3 file, the remaining time may display inaccurately.

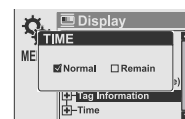

TIMER (Set Auto Power Off)

- **SLEEP POWER OFF**

Automatically power off after fixed time
(Time range can be set from 1 to 99 minutes).

▶ When the power is off, the sleep power off setting goes back to 0.



- **STOP POWER OFF**

Automatically turns power off at stop mode.
(Time range can be made from 1~60 minutes.)

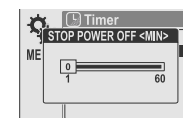

CONTROL

- **SCAN SPEED**

The fast scan speed can range from
OFF / 1x / 2x / 4x.



- **SCROLL TYPE**

Adjust scroll speed by
1x / 2x / 4x / Vertical / Horizontal.
Vertical : The scroll goes up and down
Horizontal : The scroll goes from the left to
the right.

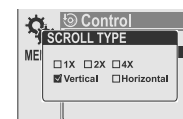

- **OPTICAL**

ON: The optical output will be enabled starting
with the next track.

⚠ **Caution** : Do not look directly into the Optical
Out jack. The laser signal can be harmful to
your eyes.

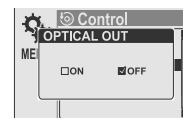

MODE (PLAYBACK MODE)

REPEAT MODE / SHUFFLE MODE

You can select a file or directory to listen to repeatedly.



You can play the selected mode simultaneously by setting REPEAT MODE / SHUFFLE MODE respectively.

(Refer to page 32 for details about each mode)



INTRO MODE

INTRO MODE plays the beginning 10 seconds of each track.

INTRO HIGHLIGHT plays 10 seconds from 1 minute into each track in sequential order.

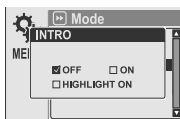

SOUND

SOUND BALANCE

Balance your sound to the right or left or keep it in the center according to your preference. When Sound Balance bar is moved to L (Left, 20), the sound outputs at the left earphone. When the bar is moved to R (Right, 20) the sound outputs at the right earphone. The default value is 0 the sound outputs the same level at both earphones.

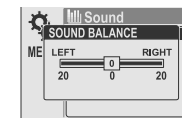

EQ

You can select 6 EQ.

EQ is selected as follows :

Normal → Rock → Jazz → Classic → Ultra Bass → User EQ

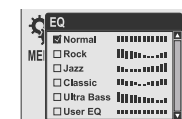

BASS BOOST

Bass Boost level is from 0 to 24dB by 2 step.

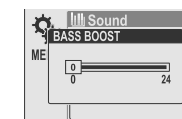

TREBLE BOOST



Treble Boost level is from 0 to 6dB by 2 step.



REC MODE

RECORD TYPE

Adjust the format to record.
You can select one of MP3 or WAV.



You can also set it by using  or  button at recording standby mode.



BIT RATE

You can adjust recording quality by setting BIT RATE.
The higher BIT RATE is, the better the recorded sound is and the lower it is, the worse the recorded sound is.

This like to more clearly state that A higher BIT RATE increases file size and shortens recording space available.

The Bit Rate can range from 40Kbps to 320kbps.
You can also set it by using  or  button at recording standby mode.

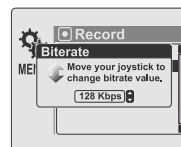

AGC

ON : When voice recording, the level is automatically controlled to help avoid distortion in the recording. Also, recordings from long distances will be improved.

AGC function is operated at voice recording mode.

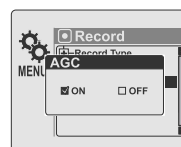

Firmware Upgradable

Upgrade your firmware at www.iriveramerica.com.

What is FIRMWARE?

It is the operating system that works in the iHP-100.
iRiver provides you with the latest and best features through Firmware Upgrade.
Visit www.iriveramerica.com to upgrade your Firmware.

How to UPGRADE?

1. Download the latest firmware upgrade file from www.iriveramerica.com
2. Extract the file and save it to the ROOT of the iHP-100.
3. Connect the AC adapter to the iHP-100.
(Caution: Only upgrade the firmware on the iHP-100 with the AC adapter connected.)
4. Select the Firmware Upgrade on the MENU.
5. Click the NAVI/MENU button after selecting 'YES' on the Alert window.
6. Check whether your LCD window shows "Firmware Upgrading..."



7. Do not turn the player off or disconnect the player from the PC until the Firmware Upgrading is done. When the power goes off automatically, the upgrade is done.
After turning the player on, confirm the Firmware Upgraded operating.

- Supported file types will have the extension MP3, WMA, ASF and WAV.
- Folders and files are sorted in alphabetical order.
- The iHP-100 can store 1,000 folders and 5,000 files (Audio or data).
- Track information is displayed either filename or ID3 TAG information.
- Physical shock can cause bad sectors on the Hard Disk inside the iHP-100. This can be recovered using Windows Scandisk.

CAUTION!

- ▶ Some earphone plugs may not fit the remote properly. Use the included earphone extension if your headphones will not plug in properly.



SAFETY

- **Avoid dropping or impacting the player.**
The player is designed to operate while walking or running, but dropping or excessively impacting the player may cause damage.
- **Avoid contacting the player with water.**
Damage to the internal parts of the player may occur if the player comes into contact with water. If your player gets wet, dry the outside with a soft cloth as soon as possible.
- Do not leave the player in a location near heat sources, or in a place subject to direct sunlight, excessive dust or sand, moisture, rain, mechanical shock, unlevelled surface, or in a car with its windows closed.
- **Keep the player away from a material with strong magnetic forces.**
This can cause malfunction in the Hard Drive.

On Headphones and Earphones

- **Road Safety**
Do not use headphones/earphones while driving, cycling, or operating any motorized vehicle. It may create a traffic hazard and is illegal in some areas. It can also be potentially dangerous to play your headsets at high volume while walking, especially at pedestrian crossings. You should exercise extreme caution or discontinue use in potentially hazardous situations.
- **Preventing hearing damage**
Avoid using headphones/earphones at high volume. Hearing experts advise against listening to continuous, loud and extended play. If you experience a ringing in your ears, reduce volume or discontinue use.
- **Consideration for others**
Keep the volume at a moderate level. This will allow you to hear outside sound and to be considerate of the people around you.

- Should any problem persist after you have checked these symptoms, consult your iRiver dealer or contact support at iRiver.com.

No Power	<ul style="list-style-type: none"> ● Check whether the battery is discharged. Check the operation after connecting AC Adapter.
No sound is heard from the player or distortion is heard during playback.	<ul style="list-style-type: none"> ● Check whether VOLUME is set to "0". Connect the remote control / earphone plug firmly. ● Check whether the plug is dirty (clean the plug with a dry and soft cloth). ● Corrupted Audio file may have a noise or sound cut off.
Characters in LCD are corrupted.	<ul style="list-style-type: none"> ● Check out Menu ▸ Display ▸ Language and confirm whether the right language has been selected.(Refer to page 36)
Poor FM Reception.	<ul style="list-style-type: none"> ● Adjust the position of the player and earphones. ● Turn off the power of other electronic devices near the player. ● The headphone cord functions as the antenna, they must be plugged in for best reception.
Failed download of a file to the player	<ul style="list-style-type: none"> ● Check the connection between your computer and the player to ensure that the cable is secure. ● Check the condition of the battery. ● Check the operation after connecting AC Adapter.
iHP will not charge properly	<ul style="list-style-type: none"> ● Check whether the adapter plug is properly connected. ● Fully charged batteries will not accept charge, the player will appear not to enter charge mode.

- Possible to loose a data by an impact from the outside, an electricity failure, or struck by lightning. A user will be responsible for the loss of the unsaved data and back up of the saved data.

1 Remote Control

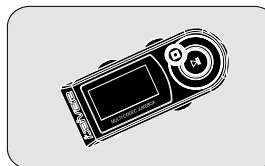

3 User Manual/ Warranty card



5 Install CD

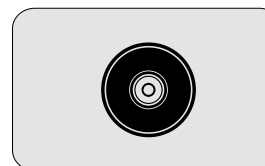

7 Earphone Extension Cable

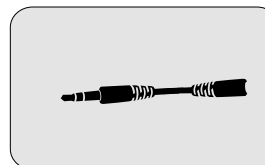

9 Carrying Case



2 Headphones and foam covers

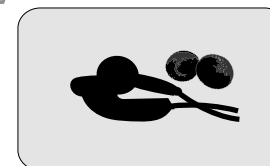

4 AC Adapter

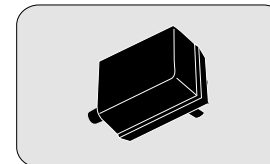

6 Line in / out Connection Cable

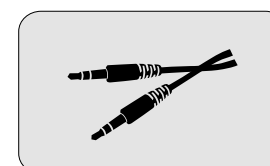

8 USB Cable

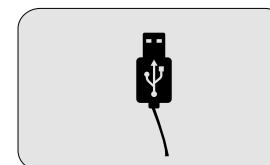

※ Accessories subject to change without notice and may vary from image shown.

Category	Item	Specifications
Audio	Frequency/Range	20Hz~20KHz
	Headphone output	20mW(L) +20mW(R) at 16 Ω Max. Volume
	S/N ratio	90dB(L), 90dB(R)(When a MP3)
	Frequency Characteristics	\pm 2dB
Audio (FM TUNER)	No. of Channels	STEREO(L+R)
	FM Frequency range	87.5MHz~108MHz
	Headphone Output	20mW(L) +20mW(R) at 16 Ω Max. Volume
	S/N ratio	50dB
	Antenna	Headphone/Earphone-Cord Antenna
File Support	File TYPE	MPEG 1/2/2.5 Layer 3, WMA , ASF, WAV
	Bit Rate	32Kbps ~ 320Kbps
	Tag	ID3 V1 , ID3 V2 2.0, ID3 V2 3.0
Power Supply	AC Adapter	DC 5V , 2A
General	Dimension	Approx. 60(W) x 19(D) x 105(H) mm
	Weight	Approx. 160 g
	Operational Temperature	0 $^{\circ}$ C ~ 40 $^{\circ}$ C
Max. Playtime	MP3 / WMA / ASF	Approx. 16 hours

Federal Communications Commission (FCC)

The device manufactured and found to comply with limits for a Class B computing device according to the specifications in FCC rules Part 15. Operation is subject to the following two conditions;

1. This device may not cause harmful interference, and
2. This device must accept any interference received, including interference that may cause undesired operation.
3. If your device needs repairs, you must arrange for the manufacturer to make them if you are to keep the device's FCC registration valid.

This equipment, like other electronic equipment, generates and uses radio frequency energy. If not installed and used according to the instructions in this manual, this equipment may cause interference with your radio and television reception.

If you think this equipment is causing interference with your radio or television reception, try turning the equipment off and on. If the interference problems stop when the equipment is switched off, then the equipment is probably causing the interference. You may be able to correct the problem by doing one or more of the following:

- Adjust the position of the radio or TV antenna
- Move away the device from the radio or TV

If necessary, consult your dealer or an experienced radio or television technician. You may find this booklet helpful: "How to Identify and Resolve Radio and TV Interference Problems"(Stock No. 004-000-00345-4), prepared by the FCC and available from the U.S Government Printing Office, Washington, DC 20402. See individual devices FCC ID and registration numbers.

For the customers in Europe



The CE mark on the player is valid only for products marketed in the European Union.