

MZ-RH10

SERVICE MANUAL

Ver. 1.0 2005.03



*US Model
Canadian Model
AEP Model
UK Model
E Model
Australian Model
Tourist Model*

US and foreign patents licensed from Dolby Laboratories.

- SonicStage is trademark or registered trademark of Sony Corporation.
- MD Simple Burner, OpenMG, "MagicGate", "MagicGate Memory Stick", "Memory Stick", Hi-MD, Net MD, ATRAC, ATRAC3, ATRAC3plus and their logos are trademarks of Sony Corporation.
- Microsoft, Windows, Windows NT and Windows Media are trademarks or registered trademarks of Microsoft Corporation in the United States and /or other countries.
- IBM and PC/AT are registered trademarks of International Business Machines Corporation.
- Macintosh is a trademark of Apple Computer, Inc. in the United States and/ or other countries.
- Pentium is a trademark or registered trademark of Intel Corporation.
- All other trademarks and registered trademarks are trademarks or registered trademarks of their respective holders.
- ™ and ® marks are omitted in this manual.
- CD and music-related data from Gracenote, Inc., copyright © 2000-2004 Gracenote. Gracenote CDDDB® Client Software, copyright 2000-2004 Gracenote. This product and service may practice one or more of the following U.S. Patents: #5,987,525; #6,061,680; #6,154,773, #6,161,132, #6,230,192, #6,230,207, #6,240,459, #6,330,593, and other patents issued or pending. Services supplied and/or device manufactured under license for following Open Globe, Inc. United States Patent 6,304,523.
Gracenote is a registered trademarks of Gracenote. The Gracenote logo and logotype, and the "Powered by Gracenote" logo are trademarks of Gracenote.

Program © 2001, 2002, 2003, 2004, 2005 Sony Corporation
Documentation © 2005 Sony Corporation

Model Name Using Similar Mechanism	NEW
MD Mechanism Type	MT-MZNH900-181J
Optical Pick-up Name	ABX-UJ

SPECIFICATIONS

Audio playing system

MiniDisc digital audio system

Laser diode properties

Material: GaAlAs

Wavelength: $\lambda = 790 \text{ nm}$

Emission duration: continuous

Laser output: less than 44.6 μW

(This output is the value measured at a distance of 200 mm from the lens surface on the optical pick-up block with 7 mm aperture.)

– Continued on next page –

PORTABLE MD RECORDER

9-879-560-01
2005C05-1
© 2005.03

Sony Corporation
Personal Audio Group
Published by Sony Engineering Corporation

SONY®

MZ-RH10

Recording and playback time

List of the recording time for each disc

When using a disc in Hi-MD mode

When recording on the recorder		Recording time ¹⁾			
Recording mode on the recorder	Codec/Bit rate	1GB Hi-MD disc	80-minute standard disc	74-minute standard disc	60-minute standard disc
PCM	Linear PCM/1.4Mbps	1 hour and 34 minutes	28 minutes	26 minutes	21 minutes
Hi-SP	ATRAC3plus/256kbps	7 hours and 55 minutes	2 hours and 20 minutes	2 hours and 10 minutes	1 hour and 40 minutes
Hi-LP	ATRAC3plus/64kbps	34 hours	10 hours and 10 minutes	9 hours and 20 minutes	7 hours and 40 minutes
When transferring from the computer		Recording time ¹⁾²⁾			
Codec/Bit rate	1GB Hi-MD disc	80-minute standard disc	74-minute standard disc	60-minute standard disc	
Linear PCM/1.4Mbps	1 hour and 34 minutes	28 minutes	26 minutes	21 minutes	
ATRAC3plus/256kbps	7 hours and 55 minutes	2 hours and 20 minutes	2 hours and 10 minutes	1 hour and 40 minutes	
ATRAC3plus/64kbps	34 hours	10 hours and 10 minutes	9 hours and 20 minutes	7 hours and 40 minutes	
ATRAC3plus/48 kbps	45 hours	13 hours and 30 minutes	12 hours and 30 minutes	10 hours	
ATRAC3/132kbps	16 hours and 30 minutes	4 hours and 50 minutes	4 hours and 30 minutes	3 hours and 40 minutes	
ATRAC3/105kbps	20 hours and 40 minutes	6 hours and 10 minutes	5 hours and 40 minutes	4 hours and 40 minutes	
ATRAC3/66kbps	32 hours and 40 minutes	9 hours and 50 minutes	9 hours	7 hours and 20 minutes	
MP3/128kbps	17 hours	5 hours	4 hours and 30 minutes	3 hours and 30 minutes	

¹⁾ Approximate time

²⁾ When transferring 4-minute tracks

When using a disc in MD mode

You cannot record in MD mode on this recorder.

When transferring from the computer		Recording time ¹⁾²⁾		
Codec/Bit rate	80-minute standard disc	74-minute standard disc	60-minute standard disc	
ATRAC(stereo)/292kbps	80 minutes	74 minutes	60 minutes	
ATRAC3/132, 105kbps	2 hours and 40 minutes	2 hours and 28 minutes	2 hours	
ATRAC3/66kbps	5 hours and 20 minutes	4 hours and 56 minutes	4 hours	

¹⁾ Approximate time

²⁾ When transferring 4-minute tracks

Revolutions

350 rpm to 3,000 rpm (CLV)

Error correction

Hi-MD:

LDC (Long Distance Code)/BIS (Burst Indicator Subcode)

MD:

ACIRC (Advanced Cross Interleave Reed Solomon Code)

Sampling frequency

44.1 kHz

Sampling rate converter

Optical (digital) input: 32 kHz/44.1 kHz/48 kHz

Audio formats supported by this recorder

Recording:

Linear PCM (44.1 kHz/16 bit)
ATRAC3plus (Adaptive TRansform Acoustic Coding 3 plus) (Hi-SP/Hi-LP)

Playback:

Linear PCM
ATRAC3plus
ATRAC3
ATRAC
MP3 (MPEG-1 Audio Layer-3/Sampling frequency 44.1 kHz/Bit rate 32 - 320 kbps (constant/variable bit rate))

Modulation system

Hi-MD:

1-7RLL (Run Length Limited)/PRML (Partial Response Maximum Likelihood)

MD:

EFM (Eight to Fourteen Modulation)

Frequency response

20 to 20,000 Hz ± 3 dB

Inputs¹⁾

MIC: stereo mini-jack (minimum input level 0.13 mV)

Line in:

stereo mini-jack for analog input (minimum input level 49 mV)
optical (digital) mini-jack for optical (digital) input

¹⁾The LINE IN (OPT) jack is used to connect either a digital (optical) cable or a line (analog) cable.

Outputs

⌚: stereo mini-jack (dedicated remote control jack)

Maximum output (DC)

Headphones:

2.8 mW + 2.8 mW (16 Ω) (European standard models)

5 mW + 5 mW (16 Ω) (Other models)

Power requirements

Sony AC Power Adaptor connected at the DC IN 3V jack:

120 V AC, 60 Hz (Models for USA, Canada, Mexico and Taiwan)

240 V AC, 50 Hz (Model for Australia)

220 V AC, 50 Hz (Models for China and Argentina)

100 - 240 V AC, 50/60 Hz (Other models)

The recorder:

Nickel metal hydride rechargeable battery

NH-14WM 1.2V 1,350 mAh (MIN) Ni-MH

LR6 (size AA) alkaline battery

AC power adaptor DC 3V

Operating temperature

+5°C (+41°F) to +35°C (+95°F)

Battery operation time²⁾

²⁾ Measured in accordance with JEITA.

Battery life¹⁾

When recording continuously in Hi-MD mode

(Unit: approx.hours)(JEITA²⁾)

Disc type	Batteries	Linear PCM	Hi-SP	Hi-LP
1GB Hi-MD disc	NH-14WM ³⁾	5.5	7.5	8.5
	LR6 ⁴⁾	2	3	3
	NH-14WM + LR6	8	11.5	12.5
60/74/80-minute standard disc	NH-14WM	5	7.5	8.5
	LR6	4	6	6.5
	NH-14WM + LR6	9.5	14.5	16.5

¹⁾ Measured with "EL Light" is set to "Auto Off" (page 58).

²⁾ Measured in accordance with the JEITA (Japan Electronics and Information Technology Industries Association) standard.

³⁾ When using a 100% fully charged nickel metal hydride rechargeable battery

⁴⁾ When using a Sony LR6 (size AA) alkaline dry battery (produced in Japan)

When playing continuously in Hi-MD mode

(Unit: approx.hours)(JEITA)

Disc type	Batteries	Linear PCM	Hi-SP	Hi-LP	MP3 ¹⁾
1GB Hi-MD disc	NH-14WM	9	12.5	14.5	13
	LR6	9.5	13.5	15.5	14.5
	NH-14WM + LR6	20	28.5	33	30
60/74/80-minute standard disc	NH-14WM	7.5	12	15	13.5
	LR6	8	13	16	14.5
	NH-14WM + LR6	17	27.5	34	30.5

¹⁾ Tracks transferred at 128 kbps

When playing continuously in MD mode

(Unit: approx.hours)(JEITA)

Disc type	Batteries	SP	LP2	LP4
60/74/80-minute standard disc	NH-14WM	13.5	15	15.5
	LR6	16	17.5	18.5
	NH-14WM + LR6	32	35.5	37

Dimensions

Approx. 80.2 × 18.9 × 84.1 mm (w/h/d)

(3¹/₄ × 3³/₄ × 3³/₈ in.) (excluding projecting parts and controls)

Mass

Approx. 120 g (4.2 oz) (the recorder only)

Approx. 147 g (5.2 oz) (including the rechargeable battery)

Supplied accessories

AC power adaptor

Remote control

Earphones

Dedicated USB cable

NH-14WM Nickel metal hydride rechargeable battery

Battery carrying case

Dry battery case

Optical cable (except US and Canadian models)

Clamp filters (small-size)

CD-ROM (SonicStage/MD Simple Burner)

Carrying pouch

* Do not play a CD-ROM on an audio CD player.

Design and specifications are subject to change without notice.

On power sources

- For use in your house: Use the AC power adaptor supplied with this recorder. Do not use any other AC power adaptor since it may cause the recorder to malfunction.

Polarity of the plug



Notes on chip component replacement

- Never reuse a disconnected chip component.
- Notice that the minus side of a tantalum capacitor may be damaged by heat.

Flexible Circuit Board Repairing

- Keep the temperature of the soldering iron around 270 °C during repairing.
- Do not touch the soldering iron on the same conductor of the circuit board (within 3 times).
- Be careful not to apply force on the conductor when soldering or unsoldering.

CAUTION
Use of controls or adjustments or performance of procedures other than those specified herein may result in hazardous radiation exposure.

TABLE OF CONTENTS

1. SERVICING NOTES	4
2. GENERAL	5
3. DISASSEMBLY	
3-1. Disassembly Flow	6
3-2. Case (Lower) Block	6
3-3. Main Board	7
3-4. Panel (Upper) Section	7
3-5. Mechanism Deck (MT-MZNH900-181J)	8
3-6. Battery Case Block	8
3-7. Gear (BSA), Gear (SB)	9
3-8. OP Service Assy	9
3-9. DC Motor SSM18D/C-NP (Spindle) (M701), DC Motor (Sled) (M702), DC Motor Unit (Over Write Head Up/Down) (M703) ...	10
3-10. Holder Assy	10
3-11. Position of Ferrite Core	11
4. TEST MODE	12
5. ELECTRICAL ADJUSTMENTS	16
6. DIAGRAMS	
6-1. Block Diagram – MD SERVO Section –	21
6-2. Block Diagram – AUDIO Section –	22
6-3. Block Diagram – POWER SUPPLY Section –	23
6-4. Schematic Diagram – MAIN Board (1/9) –	25
6-5. Schematic Diagram – MAIN Board (2/9) –	26
6-6. Schematic Diagram – MAIN Board (3/9) –	27
6-7. Schematic Diagram – MAIN Board (4/9) –	28
6-8. Schematic Diagram – MAIN Board (5/9) –	29
6-9. Schematic Diagram – MAIN Board (6/9) –	30
6-10. Schematic Diagram – MAIN Board (7/9) –	31
6-11. Schematic Diagram – MAIN Board (8/9) –	32
6-12. Schematic Diagram – MAIN Board (9/9) –	33
6-13. Printed Wiring Board – MAIN Board (Component Side) –	34
6-14. Printed Wiring Board – MAIN Board (Conductor Side) –	35
7. EXPLODED VIEWS	
7-1. Case (Lower) Section	48
7-2. Panel (Upper) Section	49
7-3. Chassis Section	50
7-4. Mechanism Deck Section (MT-MZNH900-181J)	51
8. ELECTRICAL PARTS LIST	52

SAFETY-RELATED COMPONENT WARNING!!

COMPONENTS IDENTIFIED BY MARK \triangle OR DOTTED LINE WITH MARK \triangle ON THE SCHEMATIC DIAGRAMS AND IN THE PARTS LIST ARE CRITICAL TO SAFE OPERATION. REPLACE THESE COMPONENTS WITH SONY PARTS WHOSE PART NUMBERS APPEAR AS SHOWN IN THIS MANUAL OR IN SUPPLEMENTS PUBLISHED BY SONY.

ATTENTION AU COMPOSANT AYANT RAPPORT À LA SÉCURITÉ!

LES COMPOSANTS IDENTIFIÉS PAR UNE MARQUE \triangle SUR LES DIAGRAMMES SCHÉMATIQUES ET LA LISTE DES PIÈCES SONT CRITIQUES POUR LA SÉCURITÉ DE FONCTIONNEMENT. NE REMPLACER CES COM- POSANTS QUE PAR DES PIÈCES SONY DONT LES NUMÉROS SONT DONNÉS DANS CE MANUEL OU DANS LES SUPPLÉMENTS PUBLIÉS PAR SONY.

SECTION 1 SERVICING NOTES

NOTES ON HANDLING THE OPTICAL PICK-UP BLOCK OR BASE UNIT

The laser diode in the optical pick-up block may suffer electrostatic break-down because of the potential difference generated by the charged electrostatic load, etc. on clothing and the human body. During repair, pay attention to electrostatic break-down and also use the procedure in the printed matter which is included in the repair parts. The flexible board is easily damaged and should be handled with care.

NOTES ON LASER DIODE EMISSION CHECK

The laser beam on this model is concentrated so as to be focused on the disc reflective surface by the objective lens in the optical pick-up block. Therefore, when checking the laser diode emission, observe from more than 30 cm away from the objective lens.

UNLEADED SOLDER

Boards requiring use of unleaded solder are printed with the lead-free mark (LF) indicating the solder contains no lead. (Caution: Some printed circuit boards may not come printed with the lead free mark due to their particular size)

LF : LEAD FREE MARK

Unleaded solder has the following characteristics.

- Unleaded solder melts at a temperature about 40 °C higher than ordinary solder.
Ordinary soldering irons can be used but the iron tip has to be applied to the solder joint for a slightly longer time. Soldering irons using a temperature regulator should be set to about 350 °C.
Caution: The printed pattern (copper foil) may peel away if the heated tip is applied for too long, so be careful!
- Strong viscosity
Unleaded solder is more viscous (sticky, less prone to flow) than ordinary solder so use caution not to let solder bridges occur such as on IC pins, etc.
- Usable with ordinary solder
It is best to use only unleaded solder but unleaded solder may also be added to ordinary solder.

NOTES ON REPLACEMENT OF CSP (CHIP SIZE PACKAGE) IC

Replacement of MM1690NCBE (IC401), SN761059AZQLR (IC501), SC901585VAR2 (IC601) and CXD2681-225GG (IC801) used in this set requires a special tool.

OPERATION CHECK WHEN THE MAIN BOARD IS REMOVED

In making an operation check with the MAIN board removed from the set, short the SL894 of the MAIN board with the solder before starting the operation check.

Note: Be sure to remove the solder used for shortcircuit after the repair is completed.

– MAIN BOARD (Conductor Side) –

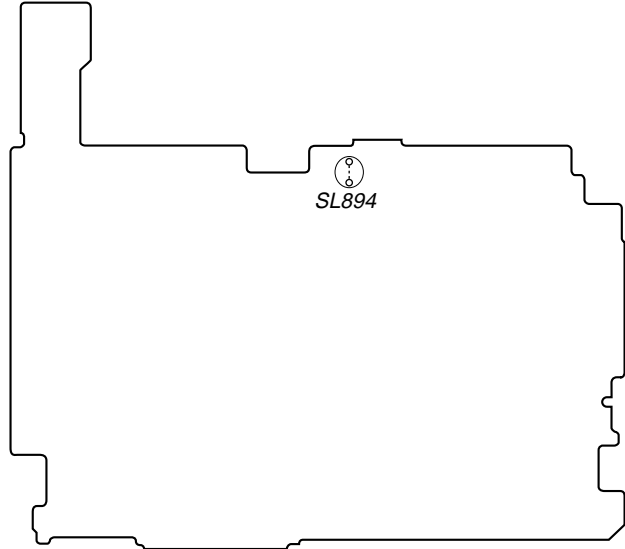

Providing the required system environment

System requirements

The following system environment is required in order to use the SonicStage Ver. 3.0/MD Simple Burner Ver. 2.0 software for the MD Walkman.

Computer	IBM PC/AT or Compatible <ul style="list-style-type: none"> • CPU: Pentium III 450 MHz or higher • Hard disk drive space: 200 MB or more (1.5 GB or more is recommended) (The amount space will vary according to Windows version and the number of music files stored on the hard disk.) • RAM: 128 MB or more Others <ul style="list-style-type: none"> • CD drive (capable of digital playback by WDM) (A CD-R/RW drive is necessary for CD writing) • Sound Board • USB port
Operating System	Factory installed: Windows XP Media Center Edition 2005/Windows XP Media Center Edition 2004/Windows XP Media Center Edition/Windows XP Professional/Windows XP Home Edition/Windows 2000 Professional/Windows Millennium Edition/Windows 98 Second Edition
Display	High Color (16bit) or higher, 800 × 600 dots or better (1024 × 768 dots or better is recommended)
Others	<ul style="list-style-type: none"> • Internet access: for Web registration, EMD services and CDDB • Windows Media Player (version 7.0 or higher) installed for playing WMA files

This software is not supported by the following environments:

- OSs other than the indicated above
- Personally constructed PCs or operating systems
- An environment that is an upgrade of the original manufacturer-installed operating system
- Multi-boot environment
- Multi-monitor environment
- Macintosh

Notes

- We do not ensure trouble-free operation on all computers that satisfy the system requirements.
- The NTFS format of Windows XP/Windows 2000 Professional can be used only with the standard (factory) settings.
- For Windows 2000 Professional users, install Service Pack 3 or later version before using the software.
- We do not ensure trouble-free operation of the system suspend, sleep, or hibernation function on all computers.

SECTION 2 GENERAL

This section is extracted from instruction manual.

Looking at controls

The recorder

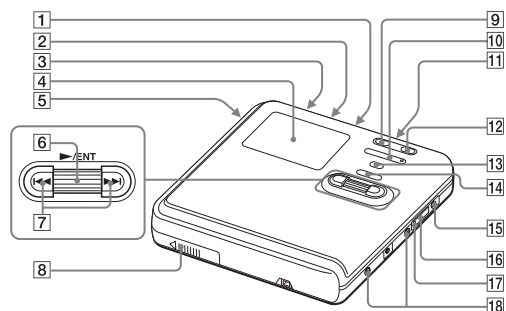

- | | |
|--|--|
| <p>1 MIC (PLUG IN POWER) jack¹⁾</p> <p>2 LINE IN (OPT) jack</p> <p>3 HOLD switch
Slide the switch in the direction of the arrow to disable the buttons on the recorder. To prevent the buttons from being accidentally operated when you carry the recorder, use this function.</p> <p>4 Display window</p> <p>5 OPEN switch</p> <p>6 Jog dial (▶) (play)/ENT</p> <p>7 ◀◀ (AMS, fast rewind), ▶▶ (AMS, fast forward) button</p> <p>8 Battery compartment</p> <p>9 (pause) button</p> <p>10 VOL (volume) +¹⁾, - button</p> | <p>11 Ⓜ (earphones) jack</p> <p>12 REC(+▶)/T MARK button</p> <p>13 ◉SEARCH/◉LIGHT/◉MENU button²⁾</p> <p>14 ■ (stop) ◉ CANCEL/CHG button</p> <p>15 DC IN 3V jack</p> <p>16 Ⓜ USB cable connecting jack</p> <p>17 The cover of the Ⓜ USB cable connecting jack</p> <p>18 Terminals for attaching dry battery case</p> |
|--|--|

¹⁾ There are tactile dots beside the VOL + button and the MIC (PLUG IN POWER) jack.
²⁾ ◉ indicates a function that requires a slight press of the button. ◉ indicates a function that requires pressing the button for 2 seconds or more.

The display window of the recorder

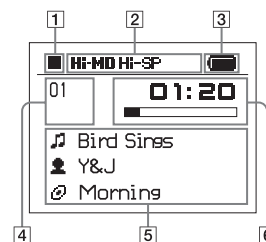

- | | |
|--|---|
| <p>1 Operating condition indication display area
Displays the indications of each operating condition.
■: stop
▶: play
 : pause
◀◀: fast rewind
▶▶: fast forward
◀◀▶▶: AMS
REC: record/record pause</p> <p>2 Selected operating condition display area
Displays the operating mode, play mode, or selected menu item, etc.</p> <p>3 Battery indication
Shows the approximate remaining battery power. If the batteries are weak, the indication becomes empty and starts flashing.</p> | <p>4 Track number and group number display area
Displays the track number or group number.</p> <p>5 Text information display area
Displays titles, menu items, error messages, etc. Titles are preceded by the following icons.
♪: track name
Ⓜ: artist name*
Ⓜ: album name*
Ⓜ: group name
Ⓜ: disc name
* Appears only for discs used in Hi-MD mode.</p> <p>6 Time display area
Displays the elapsed time, remaining time of the track or disc, etc.</p> |
|--|---|

The earphones with a remote control

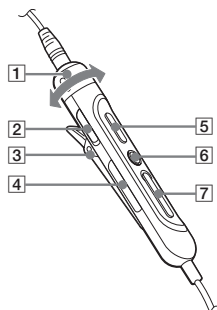

- | | |
|--|--|
| <p>1 VOL (volume) +, - control</p> <p>2 HOLD switch
Slide the switch in the direction of the arrow to disable the buttons on the remote control. To prevent the buttons from being accidentally operated when you carry the recorder, use this function.</p> | <p>3 Clip</p> <p>4 Ⓜ (group) +, - button</p> <p>5 ▶ (play, pause) button</p> <p>6 ■ (stop) button</p> <p>7 ◀◀ (AMS, fast rewind), ▶▶ (AMS, fast forward) button</p> |
|--|--|

SECTION 3 DISASSEMBLY

- This set can be disassembled in the order shown below.

3-1. DISASSEMBLY FLOW

Note 1: The process described in [] can be performed in any order.

Note 2: Without completing the process described in [], the next process can not be performed.

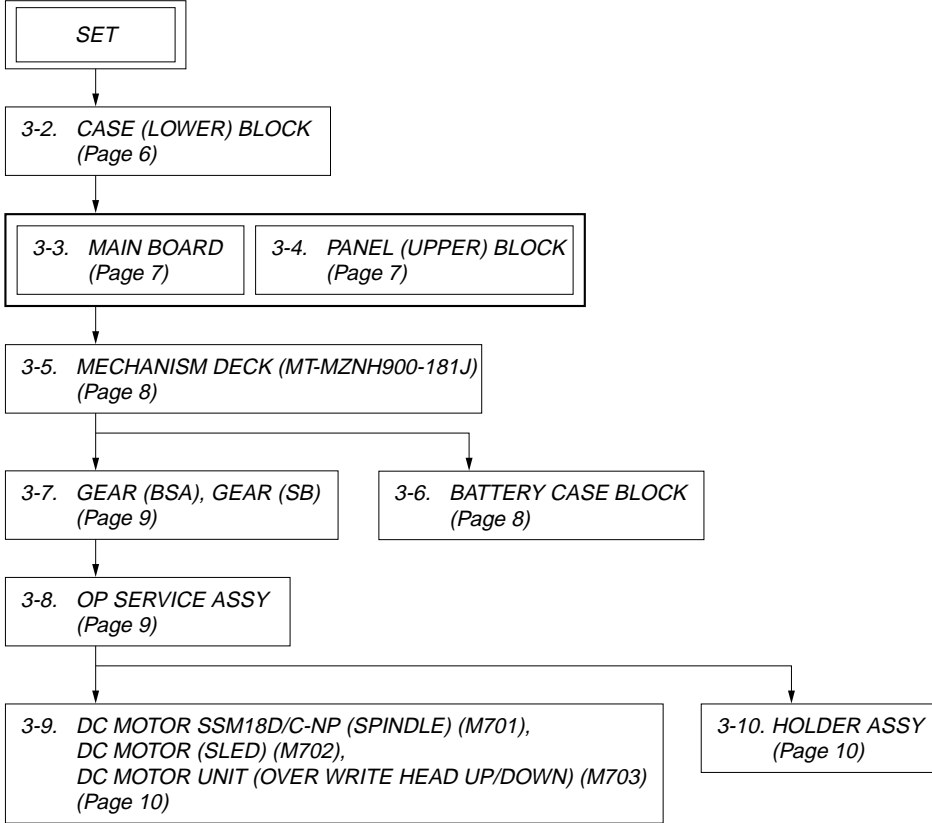

Note: Follow the disassembly procedure in the numerical order given.

3-2. CASE (LOWER) BLOCK

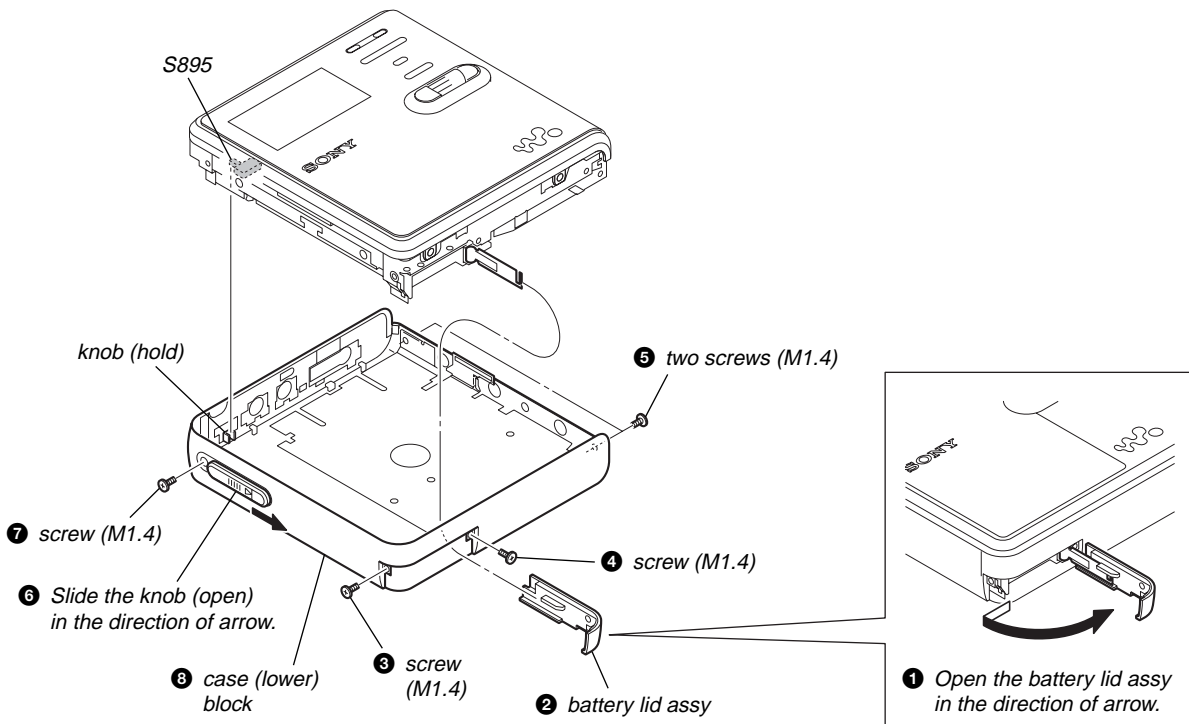

3-3. MAIN BOARD

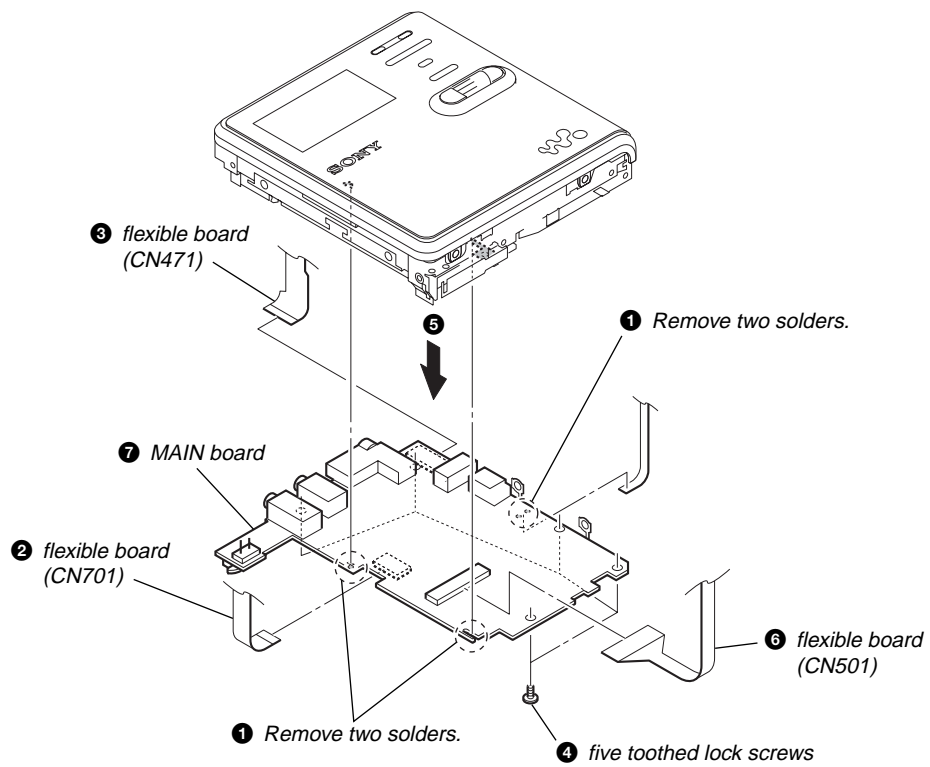

3-4. PANEL (UPPER) SECTION

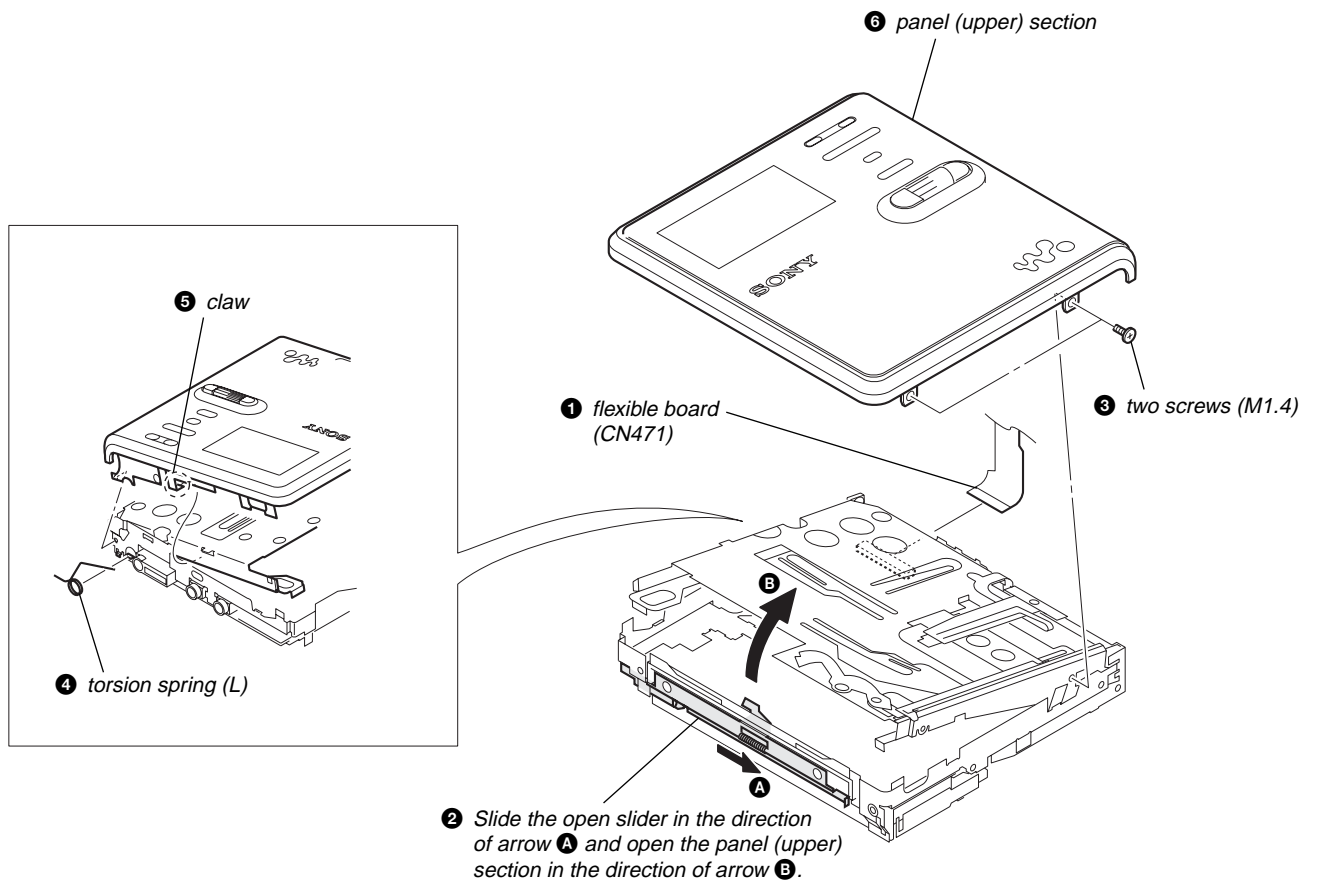

3-5. MECHANISM DECK (MT-MZNH900-181J)

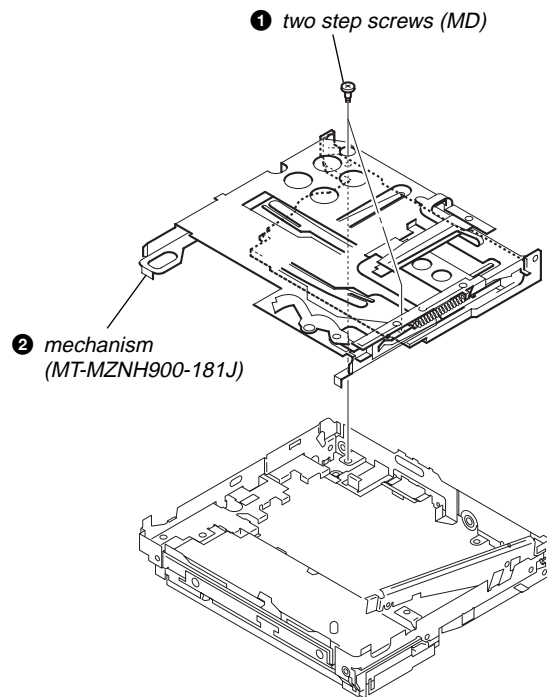

3-6. BATTERY CASE BLOCK

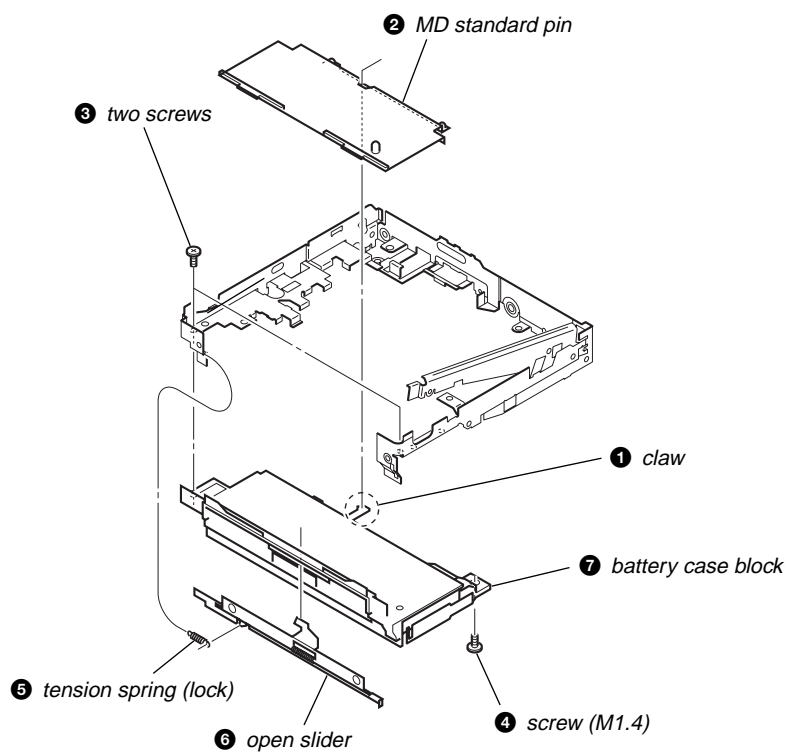

3-7. GEAR (BSA), GEAR (SB)

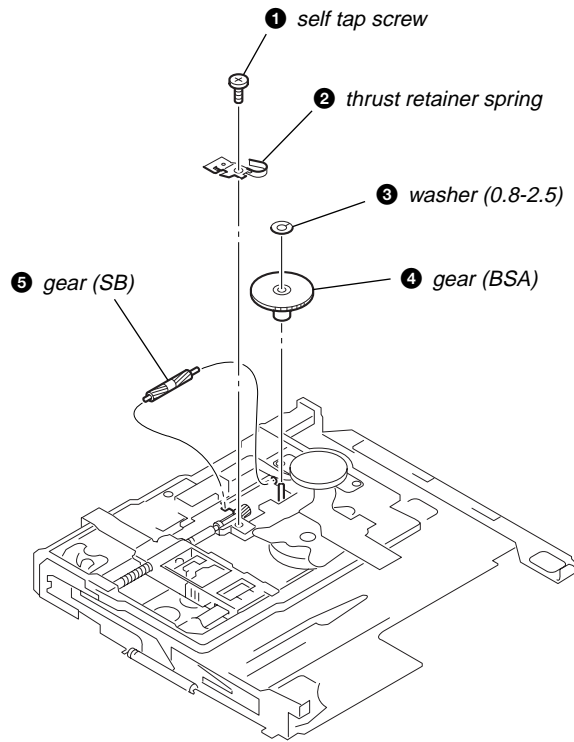

3-8. OP SERVICE ASSY

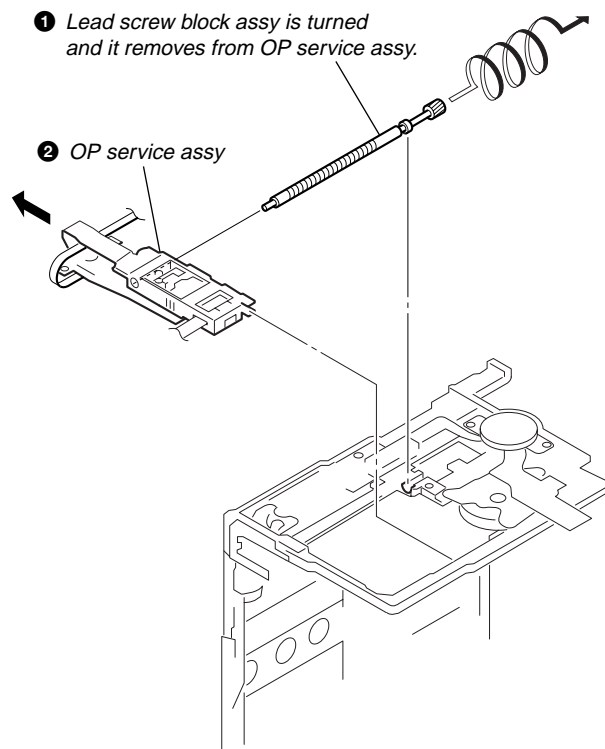

3-9. DC MOTOR SSM18D/C-NP (SPINDLE) (M701), DC MOTOR (SLED) (M702), DC MOTOR UNIT (OVER WRITE HEAD UP/DOWN) (M703)

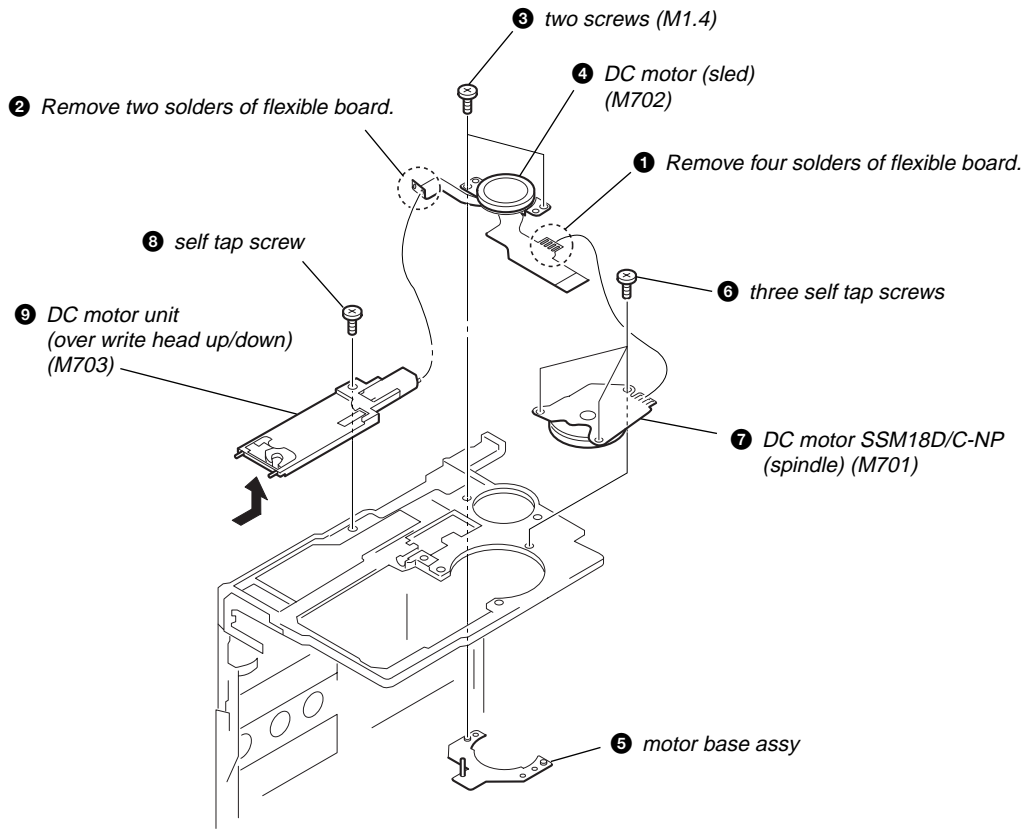

3-10. HOLDER ASSY

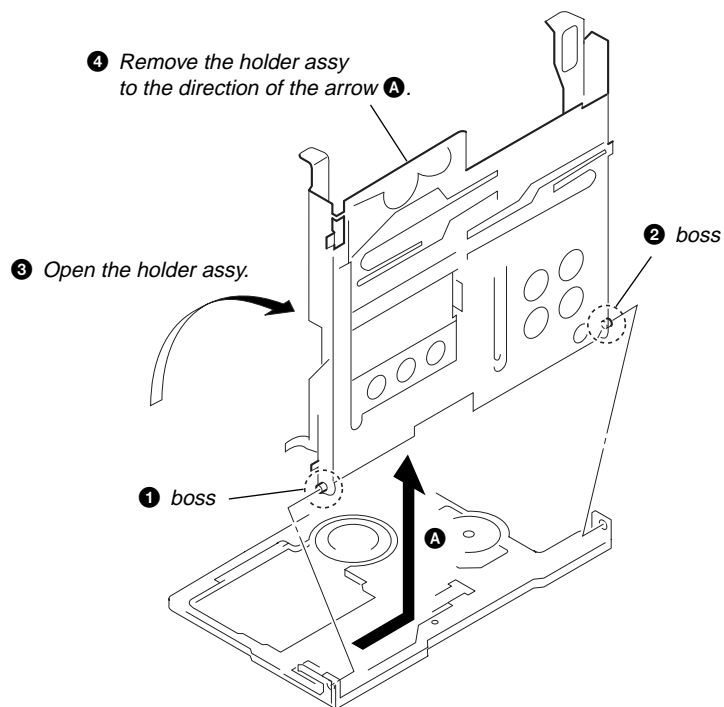

3-11. POSITION OF FERRITE CORE

-AC ADAPTOR-

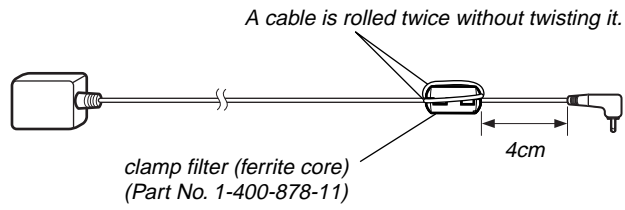

-USB CABLE-

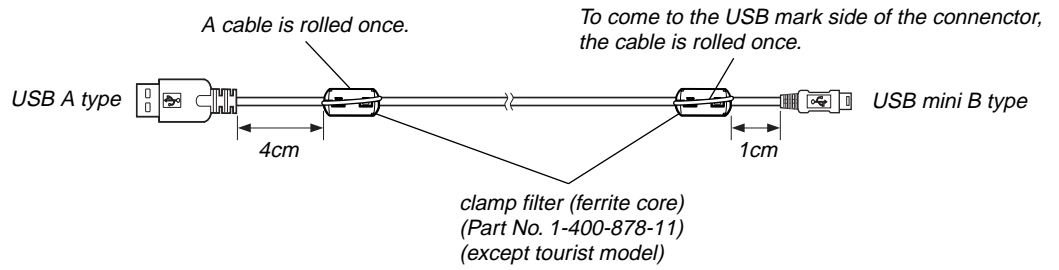

-REMOTE CONTROL UNIT-

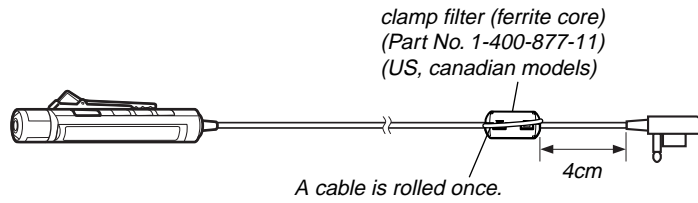

SECTION 4 TEST MODE

OUTLINE

Operation in the test mode is performed with the set. A key having no particular description in the text, indicates a set key. Also, For the LCD display, the LCD on the remote commander is shown. (The running system is displayed in set EL instead of the disk mark)

Remote commander LCD display	Set EL display
(all off)	off
(all lit)	■
(inner rotation, outer lit)	▶
(inner lit, outer off)	◀◀
(inner off, outer lit)	▶▶

1. OPERATION IN SETTING THE TEST MODE

- When the test mode becomes active, first the Display Check mode is selected.
- Other mode can be selected from the Display Check mode.
- When the test mode is set, the LCD repeats the following display.
- When the key is pressed and hold down, the display at that time is held so that display can be checked.

Display check mode:

Set EL display

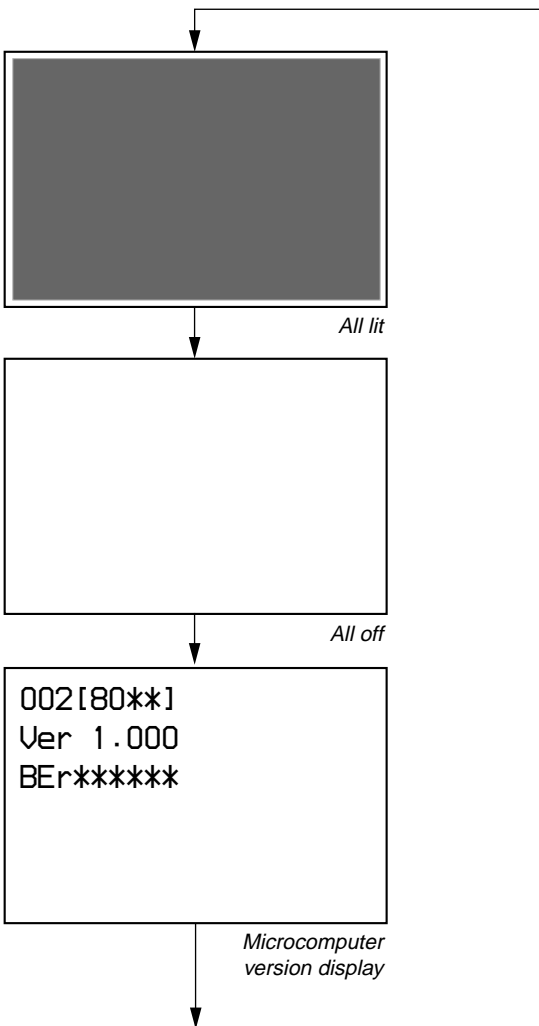

Remote commander LCD display

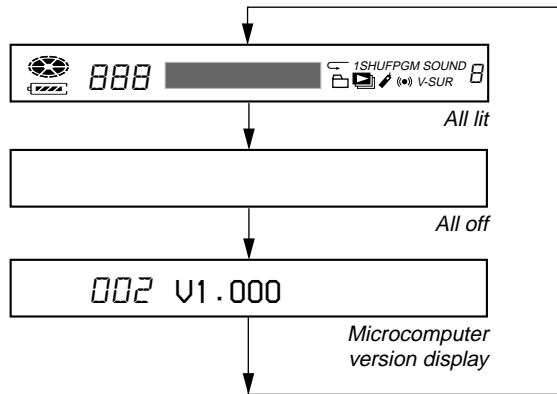

2. CONFIGURATION OF THE TEST MODE

Flow of the test mode:

Display Check Mode

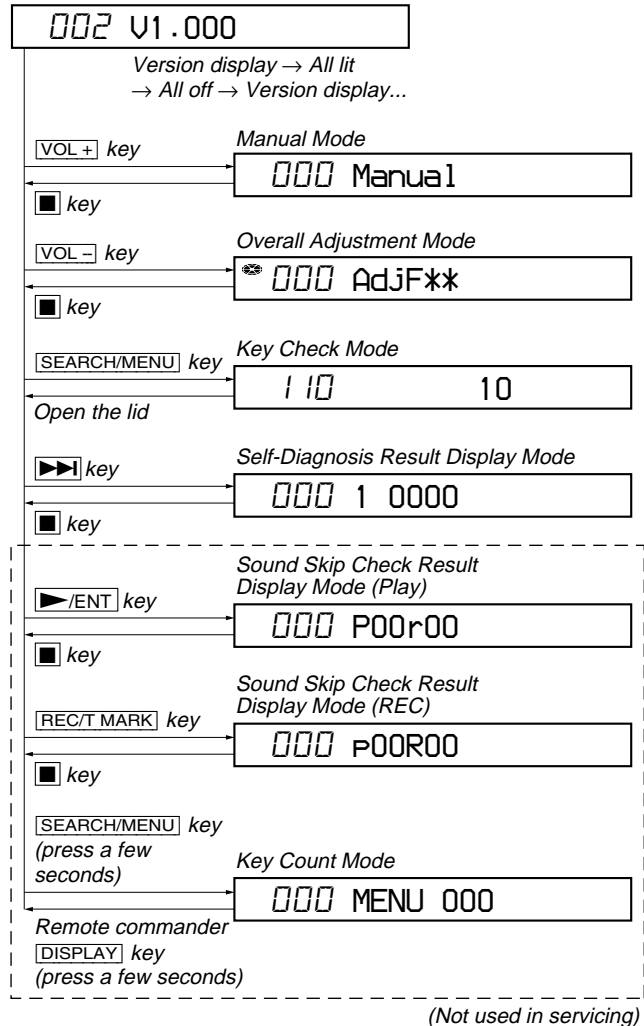

3. MANUAL MODE

This is mode to adjust or check the operation of the set by function.

Operation of The Manual Mode

1. Enter the test mode (Display Check mode).
2. Press the [VOL+] key to activate the Manual mode where the LCD displays as shown below.

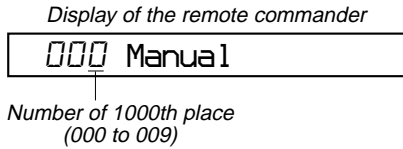

3. During Manual mode, the optical pick-up moves outward or inward while the [▶▶] or [◀◀] key is pressed for several seconds respectively.
4. Each test item is assigned with a four-digit item number; 1000th place is a top item, 100th place is a major item, 10th place is a medium item, and unit place is a minor item.

Flow of manual mode operation:

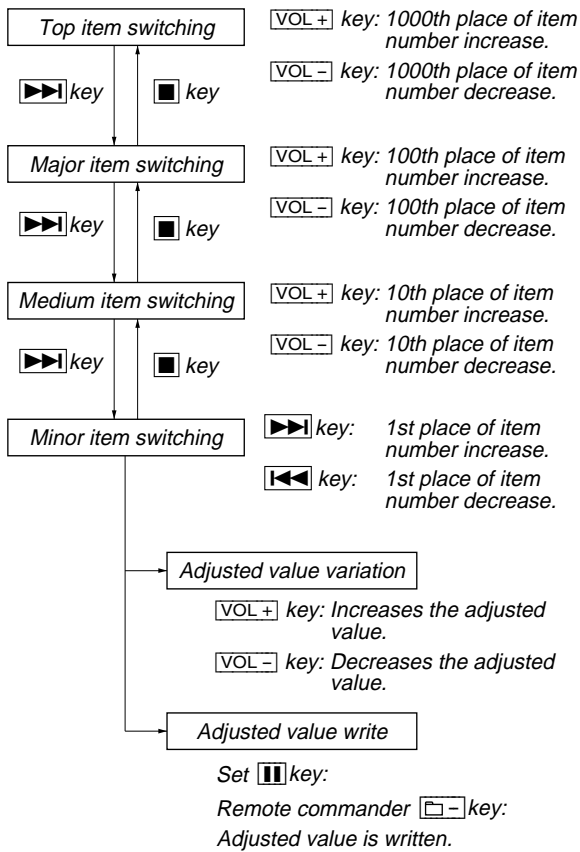

5. The display changes as shown below each time the [SEARCH/MENU] key is pressed.

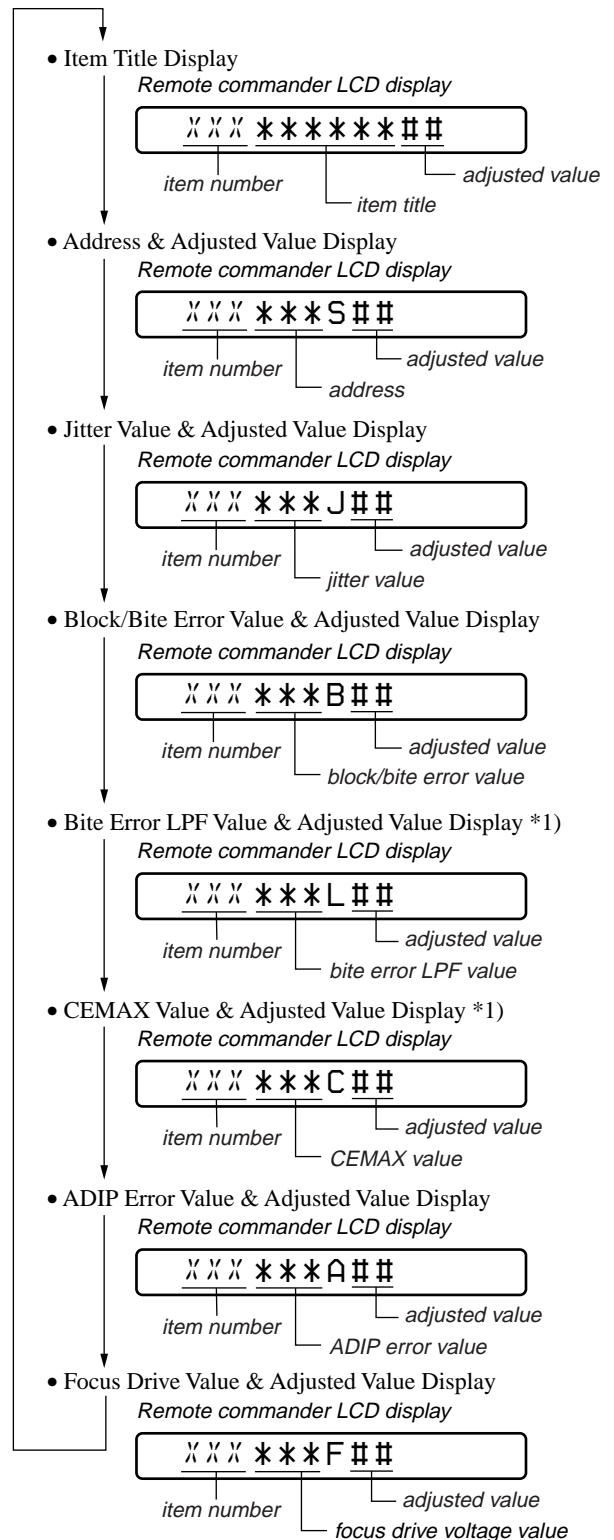

*1) It is skipped from the item number 5000 less than 8000.

6. To release the Manual mode, press the [■] key to return to the Display Check mode.

4. OVERALL ADJUSTMENT MODE

4-1. Operation of The Overall Adjustment Mode

1. Enter the test mode (Display Check mode).
2. Press the [VOL-] key to activate the Overall Adjustment mode where the LCD displays as shown below.

Display of the remote commander

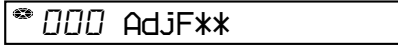

Disc mark:

Lit the inner segments: Completed the power supply adjustment.
 Lit the outer segments: Completed the check of charge function.

“**”:

If “DF” or “FF” is displayed, it mean that completed the servo overall adjustment.

3. To release the Overall Adjustment mode, press the [] key and return to the Display Check mode.

Flow of overall adjustment mode:

Overall Adjustment Mode

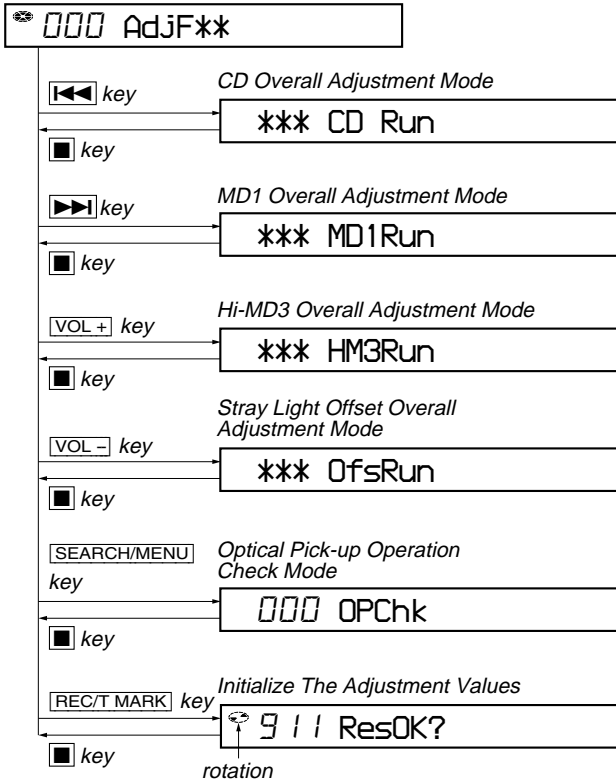

4-2. Error Message in The Overall Adjustment Mode

In the Overall Adjustment mode, if an error occurred, it displays as following table.

Display	Description
Close!	Dose not close the lid
DfDis!	Unsuitableness disc was inserted
NoChg!	Does not finish the check of charge function yet
NotCD!	Does not complete the CD Overall adjustment before the MD1 Overall adjustment
NotM1!	Does not complete the MD1 Overall adjustment before the Hi-MD3 Overall adjustment
NotH3!	Does not complete the Hi-MD3 Overall adjustment before the Stray Light Offset Overall adjustment
****NG	Error of item number “****”

5. SELF-DIAGNOSIS RESULT DISPLAY MODE

This set uses the self-diagnostic function system in which if an error occurred during the recording or playing, the mechanism control block and the power supply control block in the microcomputer detect it and record its cause as history in the nonvolatile memory. By checking this history in the test mode, you can analyze a fault and determine its location.

Total recording time is recorded as a guideline of how long the optical pick-up has been used, and by comparing it with the total recording time at the time when an error occurred in the self-diagnosis result display mode, you can determine when the error occurred.

Clear the total recording time, if the optical pick-up was replaced.

5-1. Operation of The Self-Diagnosis Result Display Mode

1. Enter the test mode (Display Check mode).
2. Press the [] key to activate the Self-Diagnosis Result Display mode where the LCD displays as shown below.

Display of the remote commander

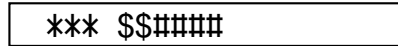

“***” : Error display code
 “\$\$” : Error rivision history code
 “####” : Addition information when error occurs

3. To release the Self-Diagnosis Result Display mode, press the [] key and return to the Display Check mode.

Flow of Self-diagnosis Result Display mode operation:

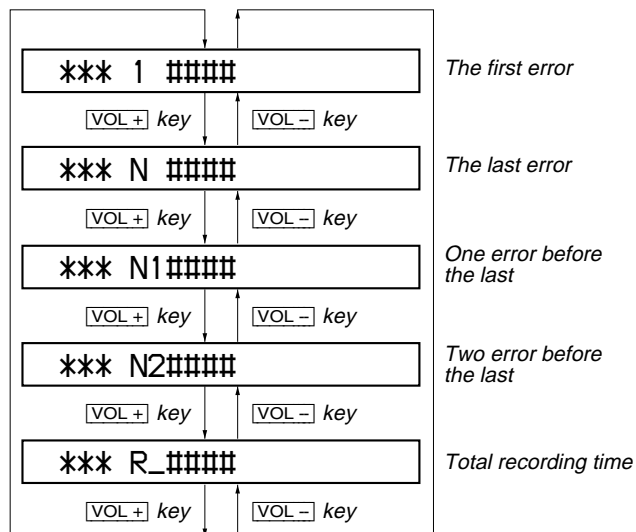

5-2. Error Code of The Self-Diagnosis Result Display Mode

Error display code	Description
000	No error
001	Attempt to access an abnormal address
002	High temperature detected
003	Focus error (no change)
004	Abnormal rotation of disc
005	Fault of disc discriminate
006	Error of access loop (no change)
007	Error of access loop (with change)
008	Could not read address
009	Focus error (with change)
012	Could not read data with SYNC
013	TOC address data error
032	Focus error, ABCD offset error
033	Tracking error, offset error
034	X1 tracking error, Tracking error, offset error

Error display code	Addition information when error occurs
000	0000
001	Illegal cluster specified when error occurs
002 to 034	Total recording time when error occurs

5-3. Clear The Total Recording Time

After replacing the optical pick-up, clear the total recording time.

1. Enter the test mode (Display Check mode).
2. Press the **[▶▶]** key to activate the Self-Diagnosis Result Display mode.
3. Press the **[VOL-]** key once to display the total recording time indication.
4. Press the **[■]** key on the set or **[□-]** key on the remote commander and display "ClrOK?".
5. Press the **[■]** key on the set or **[□-]** key on the remote commander again to display "RecT 0" and clear the total recording time.

6. KEY CHECK MODE

This mode is used for key check.

Operation of The Key Check Mode

1. Enter the test mode (Display Check mode).
2. Press the **[SEARCH/MENU]** key to activate the Key Check mode where the LCD displays as shown below.

Display of the remote commander

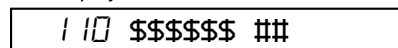

“\$\$\$\$\$\$” : Pressed key name.

When remote commander key is pressed, display becomes as “r\$\$\$\$\$”.

When the jog dial is turned, it displays “JOG+ X” or “JOG-X” (“X” is number of 1 to 3). If the jog dial is turned four click, it displays “JOG+OK” or “JOG-OK”.

“##” : Key voltage of remote commander. (Hexadecimal number)

3. When all keys check is OK on the main unit, it displays as follows.

Display of the remote commander



When all keys check is OK on the remote commander, it displays as follows.

Display of the remote commander

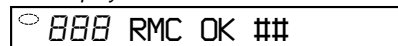

4. When all keys check are OK both the main unit and the remote commander, it display backs to the Display Check mode automatically.
5. To release the Key Check mode, open the lid and return to the Display check mode.

SECTION 5 ELECTRICAL ADJUSTMENTS

1. PRECAUTIONS FOR ADJUSTMENT

1. Adjustment must be done in the test mode only. After adjusting, release the test mode. A key having no particular description in the text, indicates a set key. Also, for the LCD display, the LCD on the remote commander is shown.
2. Use the following tools and measuring instruments.
 - Digital multi meter
 - Regulated dc power supply (two sets)
 - Ampere meter
 - Laser power meter
 - CD adjustment disc TDYS-1 (Part No. : 4-963-646-01)
 - MD1/HiMD1 hybrid adjustment disc MDW-74/GA2
 - Hi-MD3 adjustment disc HMD1GSDJ (Part No. : 8-892-388-38) *1
 - Remote commander in accessories (with LCD)
 - AC adapter in accessories

*1) Hi-MD3 adjustment disc (HMD1GSDJ) is consumable. Therefore if it is used 400 times, exchange it for a new.

2. ADJUSTMENT SEQUENCE

Adjustment must be done with the following order.

Adjustment order:

1. Entering the test mode
- Note:** Enter the test mode with a key.
2. Initialize the adjustment value
3. Power supply voltage adjustment
4. Charge function check
5. Laser power check
6. Setting the adjustment values
7. Servo Overall adjustment
8. Resume clear
9. Releasing the test mode

3. ADJUSTMENT OF THE EACH ITEM

3-1. Initialize The Adjustment Value

Procedure:

1. In the test mode (Display Check mode), press the [VOL-] key to enter the Overall adjustment mode.
2. Press the [REC/T MARK] key and display “911 ResOK?”.
3. Press the [] key on the set or [] key on the remote commander to display “911 Reset!” and initialize the adjustment values.
4. Press the [] key and back to Display Check mode.

3-2. Power Supply Voltage Adjustment

Adjustment must be done with the following order.

3-2-1. Setting

Procedure:

1. Apply the voltage of 1.2 V to the battery terminals, and enter the test mode (Display Check mode).
2. Press the [VOL+] key to enter the Manual mode.
3. Press the [VOL+] key twice to display as follows.

Display of the remote commander

002 POWER

4. Press the [] key once, press the [VOL+] key once, and press the [] key once again to display as follows.

Display of the remote commander

2 10 PwrAdj

5. Repeat the next procedures (3-2-2. PwrAdj Adjustments), and adjust all contents of “table 3-2-1. PwrAdj Specifications”.

3-2-2. PwrAdj adjustments

Repeat the following procedures and adjust all contents of “table 3-2-1. PwrAdj Specifications”.

Example Display (Item No. 2211)

2 11 VC1 **

adjustment value (hexadecimal)

Procedure:

1. Connect the digital multi meter to measuring point (refer to the following table) and CL433 (GND).
2. Press the [] key to change the item numberr to 2211.
3. Adjust with [VOL+]/[VOL-] keys so that the value of digital multi meter becomes specification value.
4. Press the [] key on the set or [] key on the remote commander to write the adjusted value. (Shifts to the next item automatically)
5. Repeat adjustment from step 3 until item number 2233.

ItemNo.	Display	Specification value	Measuring point
2211	211 VC1 **	2.05V + 0.02V	CL8029
2212	212 VC1H N **	2.25V ± 0.01V	CL8029
2213	213 VC2 **	1.20V + 0.01V	CL8001
2214	214 DDC3 L **	3.10V ± 0.015V	CL658
2215	215 DDC3 H **	3.10V ± 0.015V	CL658
2216	216 REG1 L **	3.02V ± 0.02V	CL362
2217	217 REG1 H **	3.02V ± 0.02V	CL362
2218	218 REG2 1 **	2.275V ± 0.01V	CL518
2219	219 REG2 2 **	2.480V ± 0.01V	CL518
2221	221 REG2 3 **	2.740V ± 0.01V	CL518
2222	222 REG2 4 **	2.985V ± 0.01V	CL518
2223	223 REG3 **	2.52V ± 0.02V	CL511
2224	224 VREC 1 **	0.89V ± 0.02V	CL604
2225	225 VREC 2 **	1.08V ± 0.02V	CL604
2226	226 VREC 3 **	1.52V ± 0.02V	CL604
2227	227 VREC 4 **	2.27V ± 0.02V	CL515
2228	228 VREC 5 **	2.97V ± 0.02V	CL515
2229	229 VREC 6 **	0.94V ± 0.02V	CL604
2231	231 VREC 7 **	1.28V ± 0.02V	CL604
2232	232 VREC 8 **	2.57V ± 0.02V	CL604
2233	233 VREC 9 **	2.57V ± 0.02V	CL604

Note1: “**” is adjustment value (hexadecimal number).

Note2: Ground point of all measuring points is CL433.

Note3: Refer to page 17 for adjustment location.

Table 3-2-1. PwrAdj Specifications

3-2-3. VBsAdj adjustments

Procedure:

1. In the “3-2-2. PwrAdj Adjustments” completed status, display as follows.

Display of the remote commander



2. Apply the voltage of 5 V to the CL453 and CL460 (GND).
3. Press the **▶▶** key to change the item number to 2241.
4. Adjust with **VOL+ / VOL-** keys so that the value of digital multi meter becomes specification value. (Refer to “table 3-2-2. VBsAdj Specifications”)
5. Press the **||** key on the set or **[-]** key on the remote commander to write the adjusted value.
6. Repeat adjustments to item number 2243 at the same manner as step 4 to step 5.
7. Select the item number 2244, and turn off the power supply of battery terminal.
8. Repeat adjustments to item number 2244 and 2245 at the same manner as step 4 to step 5.
9. Apply the voltage of 1.2 V to the battery terminal again.
10. Turn off the voltage of 5 V to the CL453 and CL460 (GND).
11. Press the **■** key three times and back to the Display Check mode.

ItemNo.	Display	Specification value	Measuring point
2241	241 REG4 **	1.13 V ± 0.01 V	CL8001
2242	242 REG5 **	2.05 V + 0.02 V	CL8029
2243	243 REG6 **	3.30 V ± 0.01 V	CL8055
2244	244 DDC5 L **	2.00 V + 0.02 V	CL935
2245	245 DDC5 H **	1.95 V ± 0.01 V	CL935

Note1: “**” is adjustment value (hexadecimal number).

Note2: Ground point of all adjustment points is CL433.

Table 3-2-2. VBsAdj Specifications

Adjustment Location:

– MAIN BOARD (Component Side) –

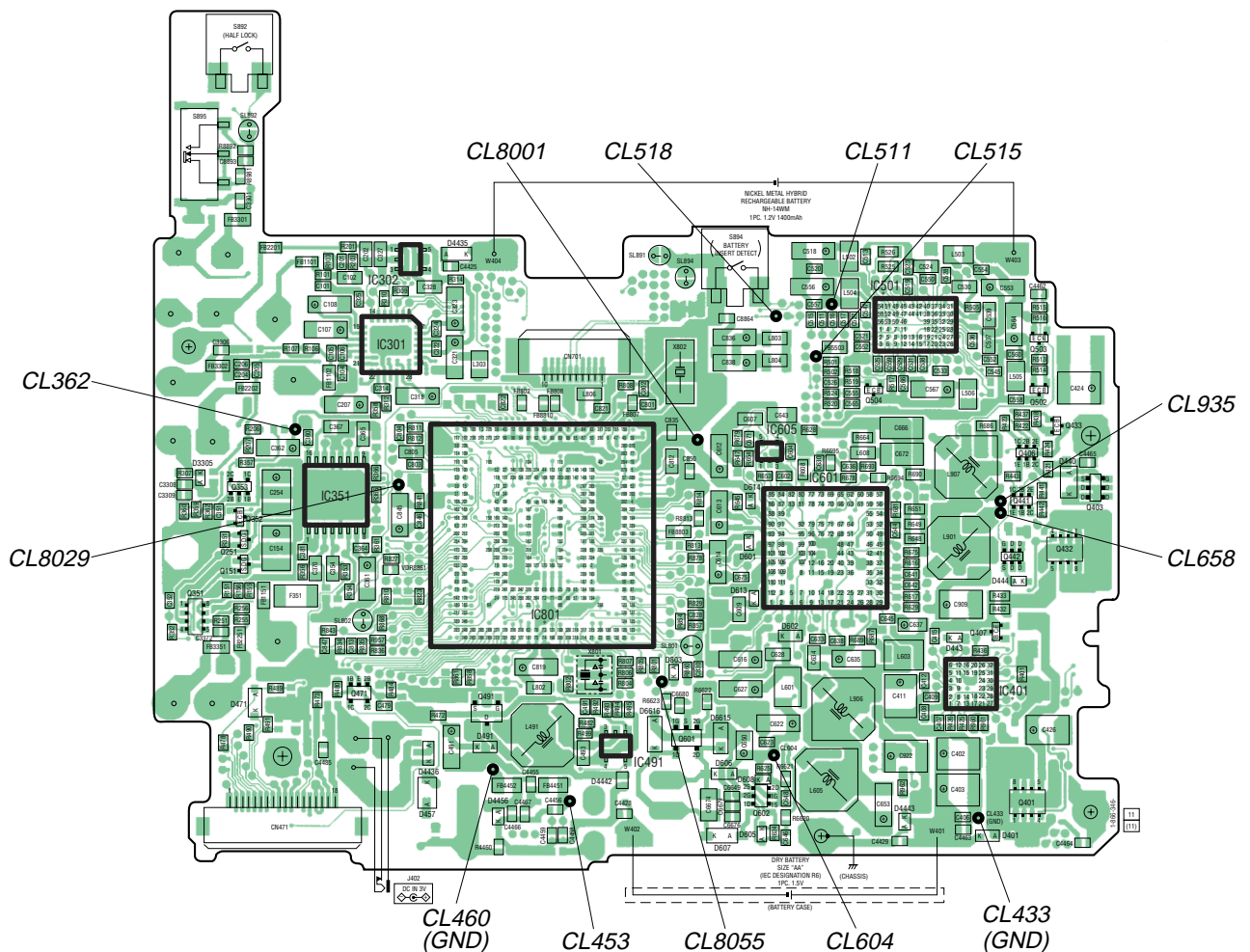

3-3. Charge Function Check

Note1: When perform this check, don't apply a voltage to battery terminals.
Note2: Be sure to disconnect the AC adapter when connecting the resistors.
 Doing so with the power supply connected causes a trouble.

3-3-1. Voltage adjustment and checks

Procedure:

1. Connect the digital multi meter to battery terminals.
2. Connect the AC adapter to the set.
3. Enter the test mode (Display Check mode).
4. Press the [VOL+] key to enter the Manual mode.
5. Press the [VOL+] key twice, press the [▶▶] key once, press the [VOL+] key once, press the [▶▶] key once, press the [VOL+] key three times to display as follows.

Display of the remote commander



6. Press the [▶▶] key to select the item number 2261 and display as follows.

Display of the remote commander



adjustment value (hexadecimal)

7. Adjust with [VOL+]/[VOL-] keys so that the value of digital multi meter becomes $1.80 \pm 0.01V$.
8. Press the [H] key on the set or [◀-] key on the remote commander to write the adjusted value.
9. Press the [▶▶] key to select the item number 2262.
10. Confirm that the value of digital multi meter is $1.20 \pm 0.024V$.
11. Press the [▶▶] key to select the item number 2263.
12. Confirm that the value of digital multi meter is $2.17 \pm 0.05V$.
13. Press the [■] key four times and back to the Display Check mode.

3-3-2. Ampere checks

Procedure:

1. Connect the 22 ohms resistor (more than 0.1 watts) and ampere meter to battery terminals.
2. Connect the AC adapter to the set.
3. Enter the test mode (Display Check mode).
4. Press the [VOL+] key to enter the Manual mode.
5. Press the [VOL+] key twice, press the [▶▶] key once, press the [VOL+] key once, press the [▶▶] key once, press the [VOL+] key three times, press the [▶▶] key four times to select the item number 2264.
6. Confirm that the value of ampere meter becomes specification value. (Refer to "table 3-3-1. Ampere Specifications")
7. Press the [■] key four times and back to the Display Check mode.
8. Cut the power supply and remove the resistor that connected to the battery terminals.
9. Repeat checks to item number 2267 at the same manner as step 1 to step 8. (Refer to "table 3-3-1. Ampere Specifications" for the kind of the resistor that connected to the battery terminals at step 1)

ItemNo.	Display	Specification value	Connected Resistor
2264	20mA I **	20 mA \pm 11 mA	22 Ω (more than 0.1W)
2265	140mA I **	140 mA \pm 14 mA	10 Ω (more than 1.0W)
2266	170mA I **	170 mA \pm 15 mA	10 Ω (more than 1.0W)
2267	500mA I **	500 mA \pm 32 mA	2.2 Ω (more than 1.5W)

Table 3-3-1. Ampere Specifications

3-4. Laser Power Check

Procedure:

1. Enter the test mode (Display Check mode).
2. Press the [VOL+] key to enter the Manual mode.
3. Open the lid and press the [◀◀] key continuously until the optical pick-up moves to the most inward track.
4. Press the [VOL-] key once to display as follows.

Display of the remote commander



5. Press the [▶▶] key three times to select the item number 9111 and display as follows.

Display of the remote commander

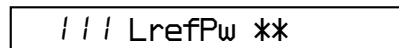

6. Set the laser power meter so that the laser beam from the optical pick-up aims at the objective lens of laser power meter at right angle. (Confirm it with the disc not inserted)
7. Confirm that the value of laser power meter is $0.860 \text{ mW} \pm 19.2\%$.
8. Press the [▶▶] key to select the item number 9112.
9. Confirm that the value of laser power meter is $0.763 \text{ mW} \pm 18.2\%$.
10. Press the [▶▶] key to select the item number 9113.
11. Confirm that the value of laser power meter is $6.87 \text{ mW} \pm 12\%$.
12. Press the [■] key four times and back to the Display Check mode.

3-5. Setting The Adjustment Values

3-5-1. Hi-MD3 setting

Preparation:

1. Perform calculation every item based on the data given by the Hi-MD3 adjustment disc by referring to the following table. (Round off the value in decimal place)
2. Convert the calculated value into hexadecimal number.

Note: The Hi-MD3 adjustment parameters vary depending on the disc, and therefore use the parameters of the disc used when performing the adjustment.

Item No.	Calculating formula (*3)
0211	Pr_nominal / 0.05
(*1)	Por / 0.05
0212	Kr \times (-100)
0213	Pw_nominal / 0.05
(*2)	Ppw / 0.05
0214	Kw \times (-100)
0215	Prmin / 0.05
0216	Pwmin / 0.05

- *1) If the "Pr_nominal" value is indicated, use the "Pr_nominal" value and not used "Por" value.
- *2) If the "Pw_nominal" value is indicated, use the "Pw_nominal" value and not used "Ppw" value.
- *3) Round off after the decimal point.

Table 3-5-1. Hi-MD3 adjustment parameter

Example of Calculation:

Item No.	Parameter		Result	
			Decimal	Hexadecimal
0211	Pr_nominal	2.48 mW	50	32h
0212	Kr	-0.3 %/°C	30	1Eh
0213	Pw_nominal	7.35 mW	147	93h
0214	Kw	-0.4 %/°C	40	28h
0215	Prmin	1.9 mW	38	26h
0216	Pwmin	5.8 mW	116	74h

Procedure:

1. Enter the test mode (Display Check mode).
2. Press the [VOL+] key to enter the Manual mode.
3. Press the [▶▶] key once, press the [VOL+] key once, and press the [▶▶] key once again to display as follows.

Display of the remote commander



4. Press the [▶▶] key once to select the item number 0211.
5. Adjust with [VOL+]/[VOL-] keys so that the adjustment value of LCD becomes calculated value.
6. Press the [■] key on the set or [□-] key on the remote commander to write the adjusted value.
7. Press the [▶▶] key to next item.
8. Repeat adjustment from step 4 until item number 0216.

3-5-2. Destination setting

Procedure:

1. Enter the test mode (Display Check mode).
2. Press the [VOL+] key to enter the Manual mode.
3. Press the [▶▶] key five time to select the item number 0113 and display as follows.

Display of the remote commander



adjustment value (hexadecimal)

4. Press the [VOL+]/[VOL-] key and set the according value to each destination referring to the following table.
5. Press the [■] key on the set or [□-] key on the remote commander to write the adjusted value.
6. Press the [▶▶] key to select the item number 0114.
7. Repeat adjustment from step 3.
8. Press the [■] key four times and back to the Display Check mode.

Destination	Setting value	
	Item No. 0113	Item No. 0114
US and Canadian	20	80
AEP, UK and East European	A0	80
E, Hong Kong, Korean, Australian and Tourist	24	80

Table 3-5-2. Destination Setting

3-5-3. Other setting

Procedure:

1. Enter the test mode (Display Check mode).
2. Press the [VOL+] key to enter the Manual mode.
3. Press the [VOL+] key once and press the [▶▶] key five time to select the item number 1113 and display as follows.

Display of the remote commander

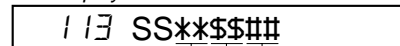

adjustment value (hexadecimal)

4. Adjust with [VOL+]/[VOL-] keys so that the adjustment value of “**” on the LCD becomes “1A”.
5. Press the [■] key on the set or [□-] key on the remote commander to write the adjusted value. (\$\$ blinks and disc mark rotates on the LCD)
6. Adjust with [VOL+]/[VOL-] keys so that the adjustment value of “\$\$” on the LCD becomes “20”.
7. Press the [■] key on the set or [□-] key on the remote commander to write the adjusted value. (### blinks and disc mark rotates on the LCD)
8. Adjust with [VOL+]/[VOL-] keys so that the adjustment value of “###” on the LCD becomes “94”.
9. Press the [■] key on the set or [□-] key on the remote commander to write the adjusted value.
10. Press the [VOL+] key once to change the adjustment value of “**” on the LCD into “1B”.
11. Press the [■] key on the set or [□-] key on the remote commander to write the adjusted value. (\$\$ blinks and disc mark rotates on the LCD)
12. Adjust with [VOL+]/[VOL-] keys so that the adjustment value of “\$\$” on the LCD becomes “F1”.
13. Press the [■] key on the set or [□-] key on the remote commander to write the adjusted value. (### blinks and disc mark rotates on the LCD)
14. Adjust with [VOL+]/[VOL-] keys so that the adjustment value of “###” on the LCD becomes “1A”.
15. Press the [■] key on the set or [□-] key on the remote commander to write the adjusted value.
16. Press the [■] key four times and back to the Display Check mode.

3-6. Servo Overall Adjustment

Note1: Be sure to adjustment so that the set is horizontal and the LCD is upside. Unless performed in that state, it is not adjusted correctly.

Note2: If NG is displayed in the middle of this adjustments, perform “3-2. Initialize The Adjustment Value” and “3-5. Setting The Adjustment Values” again, then retry this adjustments from step 1.

Procedure:

1. Enter the test mode (Display Check mode).
2. Press the **[VOL-]** key to enter the Overall Adjustment mode.
3. Insert the CD adjustment disc (TDYS-1).
4. Put the main unit horizontal so that the LCD becomes upside, and press the **[◀◀]** key.
5. Wait until “CD OK” is displayed on the LCD.
6. Insert the MD1/HiMD1 hybrid adjustment disc (MDW-74/GA2).
7. Put the main unit horizontal so that the LCD becomes upside, and press the **[▶▶]** key.
8. Wait until “MD1 OK” is displayed on the LCD.
9. Insert the Hi-MD3 adjustment disc (HMD1GSDJ).
10. Put the main unit horizontal so that the LCD becomes upside, and press the **[VOL+]** key.
11. Wait until “HMD3OK” is displayed on the LCD.
12. Eject the disc and close the lid.
13. Put the main unit horizontal so that the LCD becomes upside, and press the **[VOL-]** key.
14. Wait until “OfstOK” is displayed on the LCD.
15. Press the **[■]** key and back to the Display Check mode.

3-7. Resume Clear

Procedure:

1. Enter the test mode (Display Check mode).
2. Press the **[VOL+]** key to enter the Manual mode.
3. Press the **[VOL+]** key once, press the **[▶▶]** key once, press the **[VOL-]** key once, press the **[▶▶]** key once, and press the **[VOL+]** key twice, press the **[▶▶]** key three times to select the item number 1933.
4. Press the **[II]** key on the set or **[☐-]** key on the remote commander to resume clear.
5. Press the **[■]** key four times and back to the Display Check mode.

3-8. Releasing The Test Mode

Note: When the power supply is switched on in the state where all electrical adjustments have not finished, it is displayed on LCD as “Error EE” and the usual operation can't be performed. When a power supply is accidentally turn off in the middle of electrical adjustments, it is again set as test mode and electrical adjustments is mode to complete.

SECTION 6 DIAGRAMS

6-1. BLOCK DIAGRAM – MD SERVO Section –

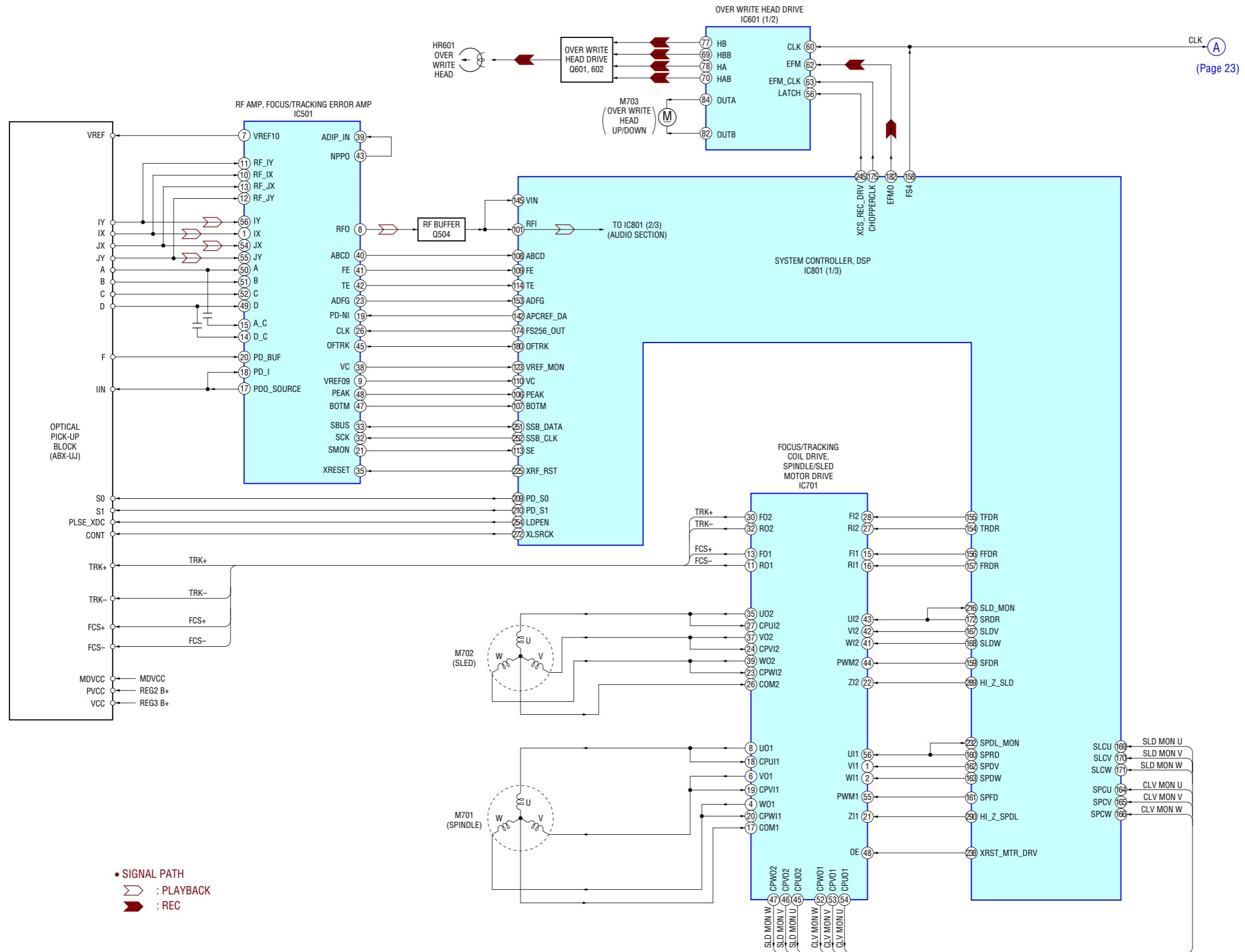

6-2. BLOCK DIAGRAM – AUDIO Section –

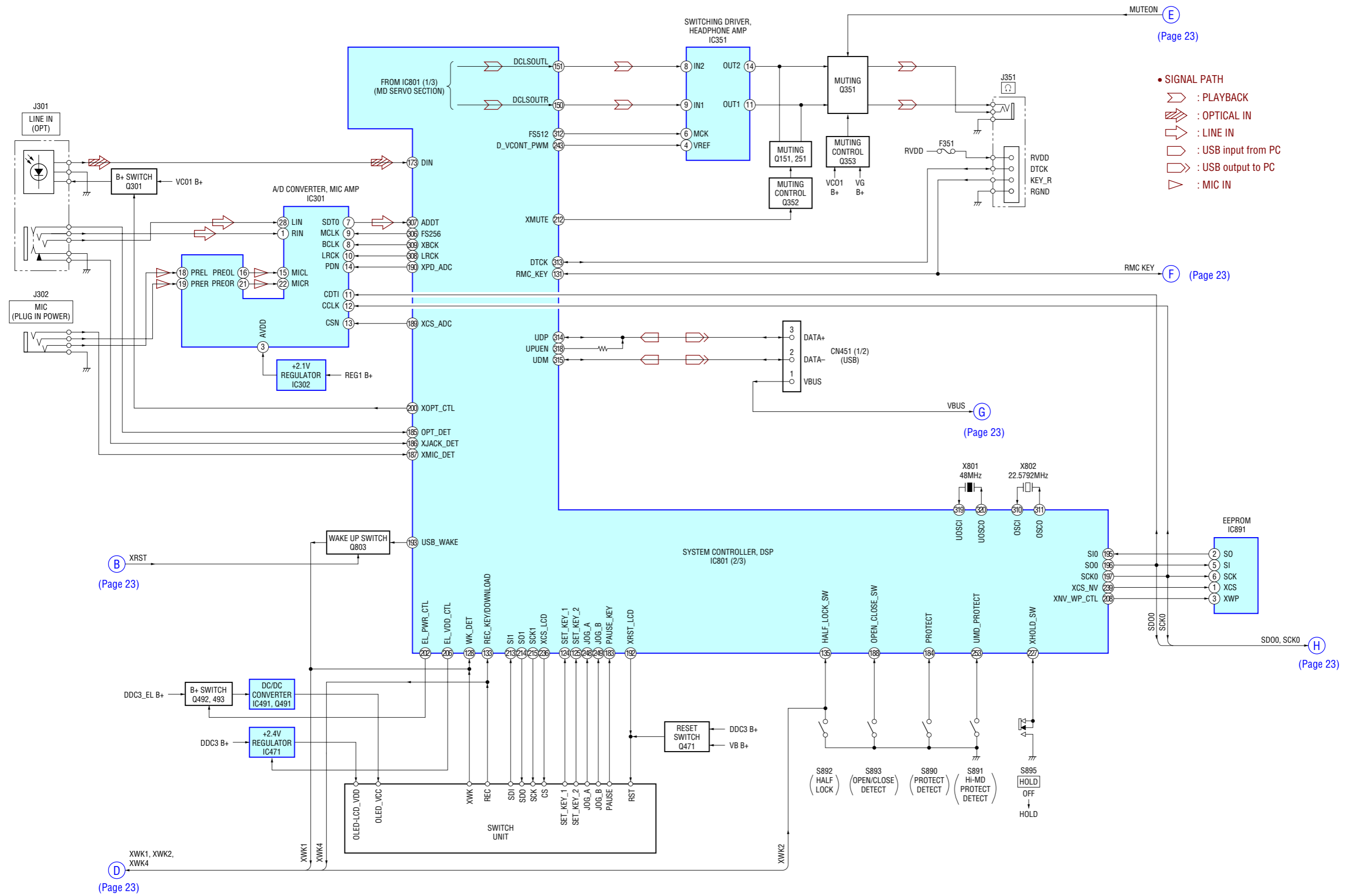

6-3. BLOCK DIAGRAM – POWER SUPPLY Section –

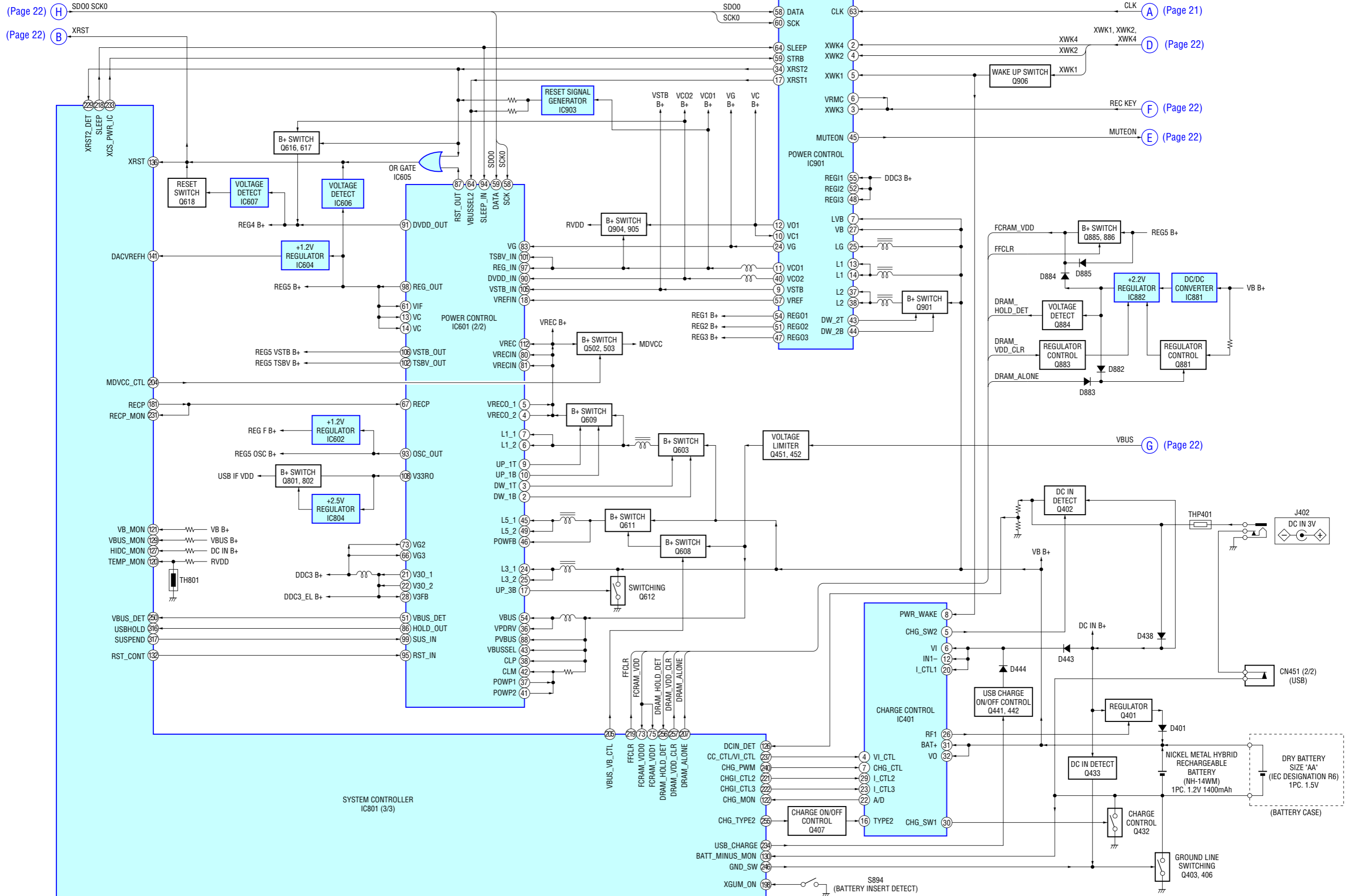

(Page 22) H
(Page 22) B

CLK (A) (Page 21)

XWK1, XWK2, XWK4 (D) (Page 22)

REC KEY (F) (Page 22)

MUTEON (E) (Page 22)

VBUS (G) (Page 22)

• Note For Printed Wiring Boards and Schematic Diagrams

Note on Printed Wiring Board:

- : parts extracted from the component side.
- : parts extracted from the conductor side.
- △ : internal component.
- : Pattern from the side which enables seeing. (The other layers' patterns are not indicated.)

Caution:
 Pattern face side: Parts on the pattern face side seen from the pattern face are indicated.
 Conductor Side: Parts on the conductor side are indicated.
 Parts face side: Parts on the parts face side seen from the parts face are indicated.
 Component Side: Parts on the component side are indicated.

* Replacement of IC401, IC501, IC601 and IC801 used in this set requires a special tool.

- MAIN board is multi-layer printed board. However, the patterns of intermediate-layer have not been included in this diagrams.
- Lead Layouts

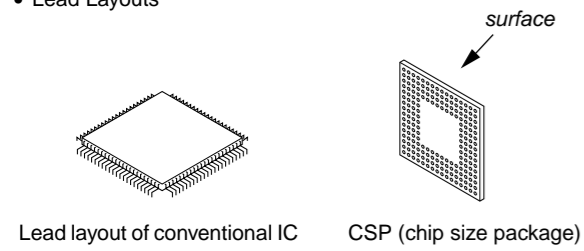

Note on Schematic Diagram:

- All capacitors are in μF unless otherwise noted. (p: pF) 50 WV or less are not indicated except for electrolytics and tantalums.
- All resistors are in Ω and $1/4 W$ or less unless otherwise specified.
- △ : internal component.
- : panel designation.

Note:
 The components identified by mark △ or dotted line with mark △ are critical for safety. Replace only with part number specified.

Note:
 Les composants identifiés par une marque △ sont critiques pour la sécurité. Ne les remplacer que par une pièce portant le numéro spécifié.

- : B+ Line.
- Power voltage is dc 1.5 V and fed with regulated dc power supply from battery terminal.
- Voltages and waveforms are dc with respect to ground under no-signal conditions.
- no mark : PLAYBACK
- * : Impossible to measure
- Voltages are taken with a VOM (Input impedance 10 M Ω). Voltage variations may be noted due to normal production tolerances.
- Waveforms are taken with a oscilloscope. Voltage variations may be noted due to normal production tolerances.
- Circled numbers refer to waveforms.
- Signal path.
- ▷ : PLAYBACK
- ◀ : REC
- ◀ : OPTICAL IN
- ▷ : LINE IN
- ▷ : USB input from PC
- ▷ : USB output to PC
- ▷ : MIC IN

* Replacement of IC401, IC501, IC601 and IC801 used in this set requires a special tool.

- The voltage and waveform of CSP (chip size package) cannot be measured, because its lead layout is different form that of conventional IC.

• Waveforms

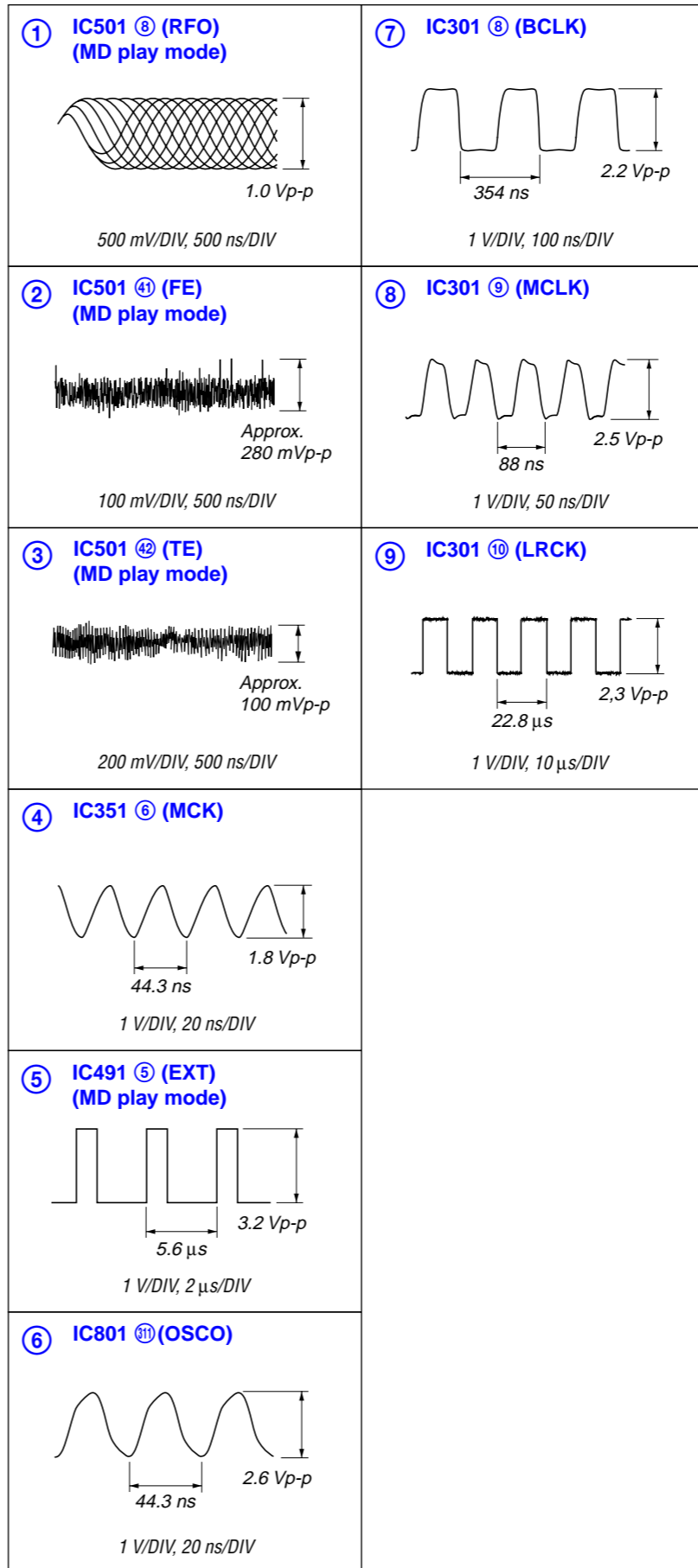

6-4. SCHEMATIC DIAGRAM – MAIN Board (1/9) – • See page 36 for IC Block Diagrams.

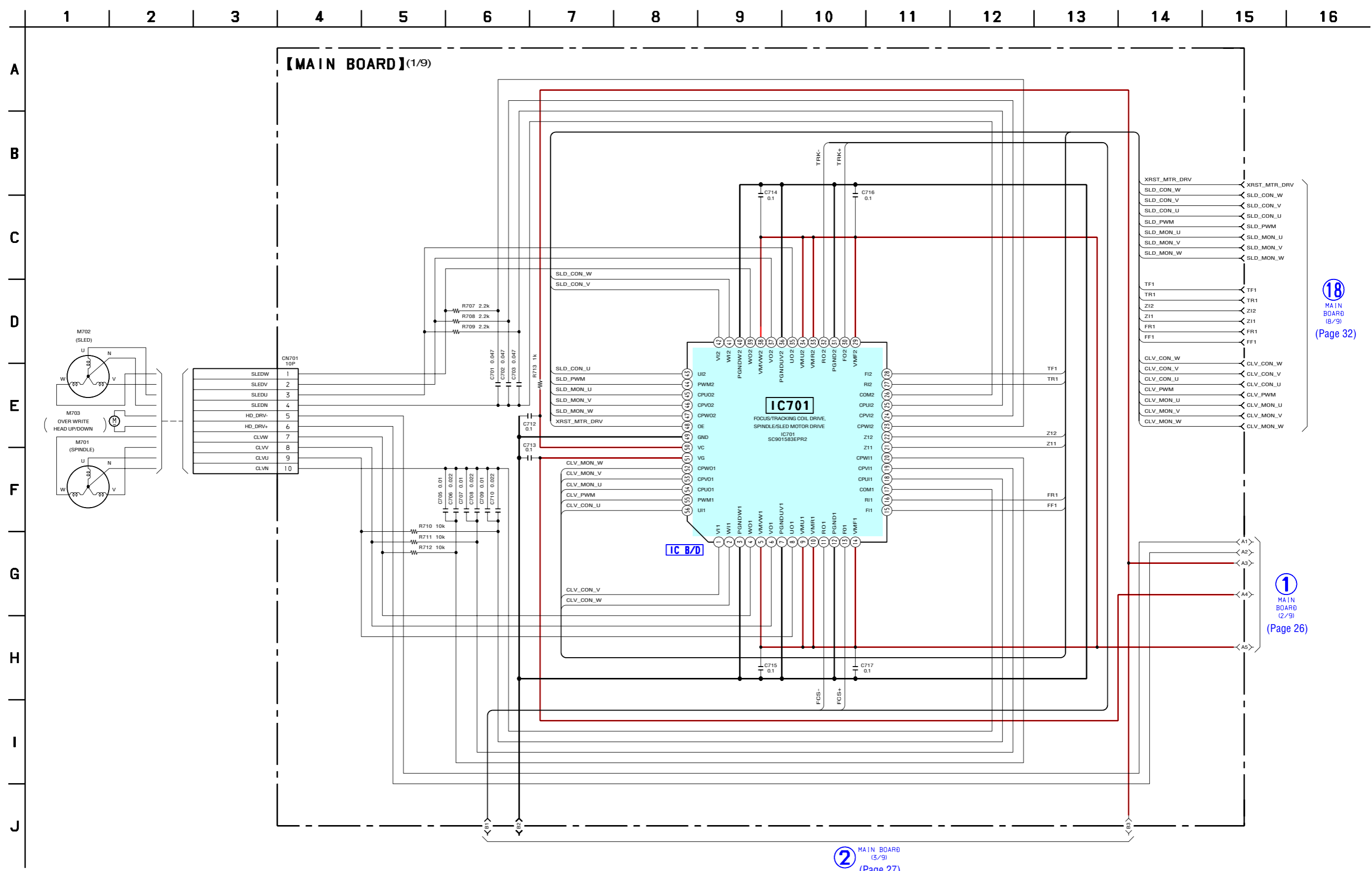

18 MAIN BOARD (8/9) (Page 32)

1 MAIN BOARD (2/9) (Page 26)

2 MAIN BOARD (3/9) (Page 27)

6-5. SCHEMATIC DIAGRAM – MAIN Board (2/9) – See page 36 for IC Block Diagrams.

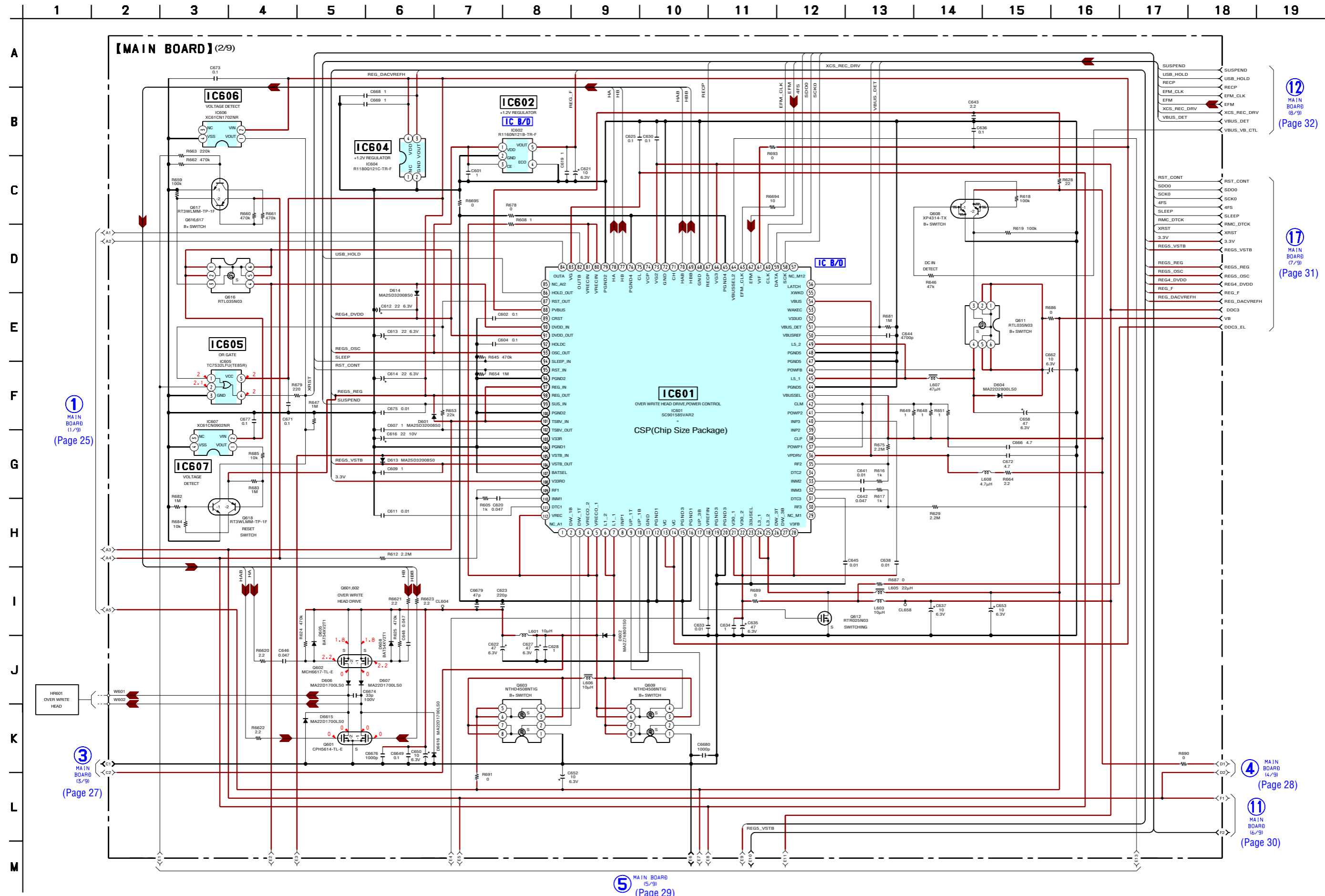

6-6. SCHEMATIC DIAGRAM – MAIN Board (3/9) – • See page 24 for Waveforms. • See page 36 for IC Block Diagrams.

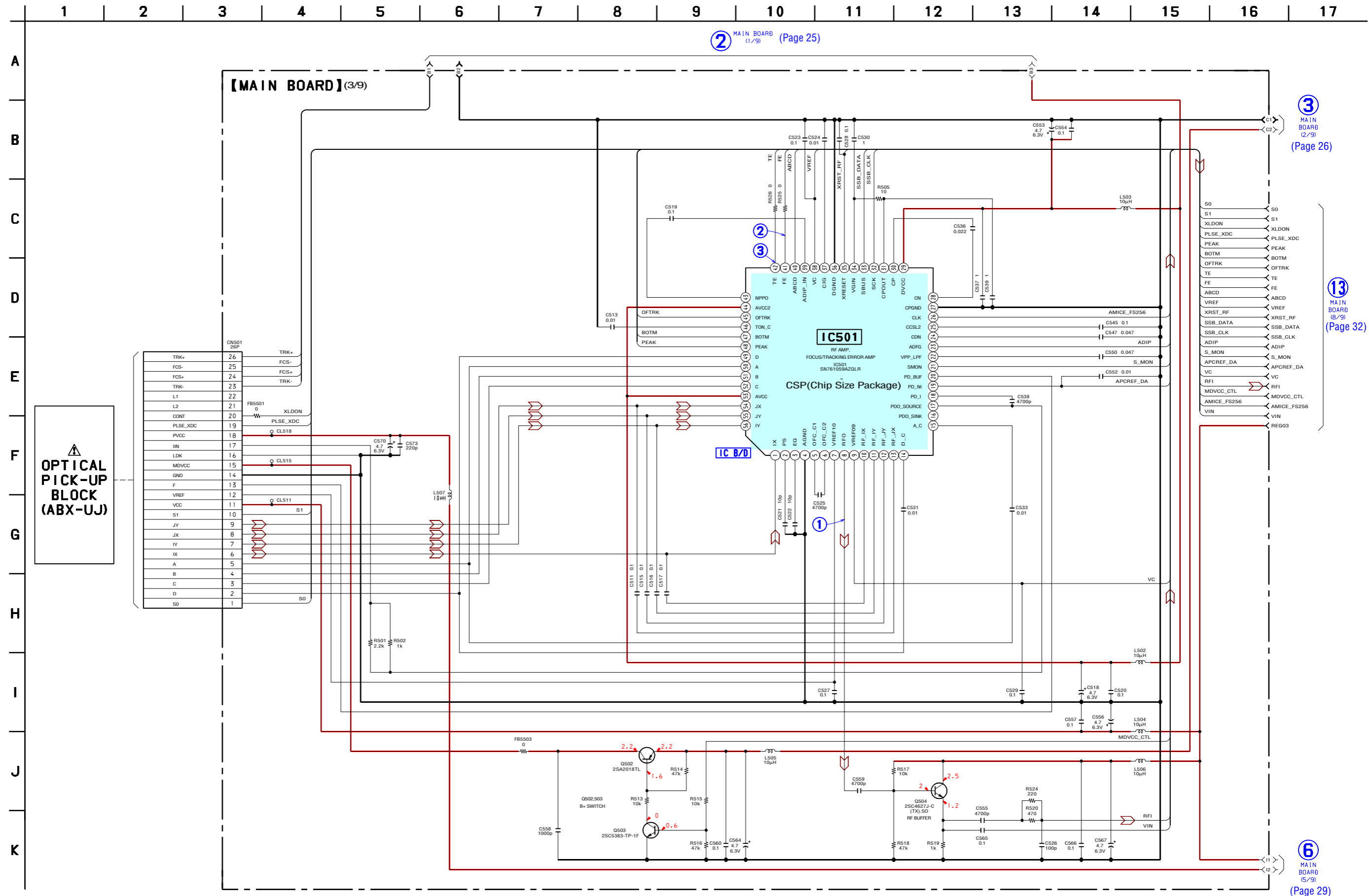

The components identified by mark Δ or dotted line with mark Δ are critical for safety. Replace only with part number specified. Les composants identifiés par une marque Δ sont critiques pour la sécurité. Ne les remplacer que par une pièce portant le numéro spécifié.

6-7. SCHEMATIC DIAGRAM – MAIN Board (4/9) – • See page 36 for IC Block Diagrams.

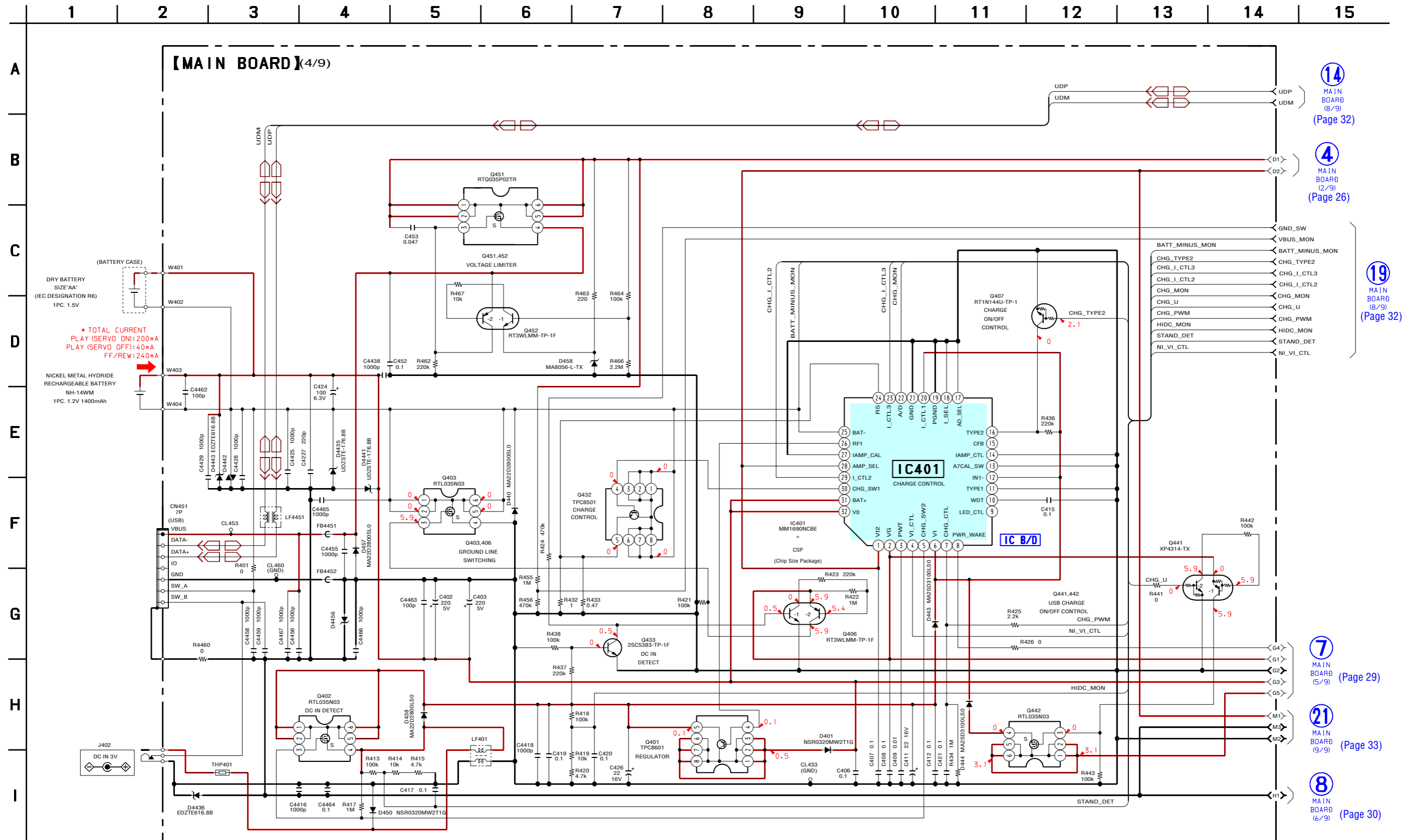

14 MAIN BOARD (8/9) (Page 32)

4 MAIN BOARD (2/9) (Page 26)

19 MAIN BOARD (8/9) (Page 32)

7 MAIN BOARD (5/9) (Page 29)

21 MAIN BOARD (9/9) (Page 33)

8 MAIN BOARD (6/9) (Page 30)

6-8. SCHEMATIC DIAGRAM – MAIN Board (5/9) – • See page 36 for IC Block Diagrams.

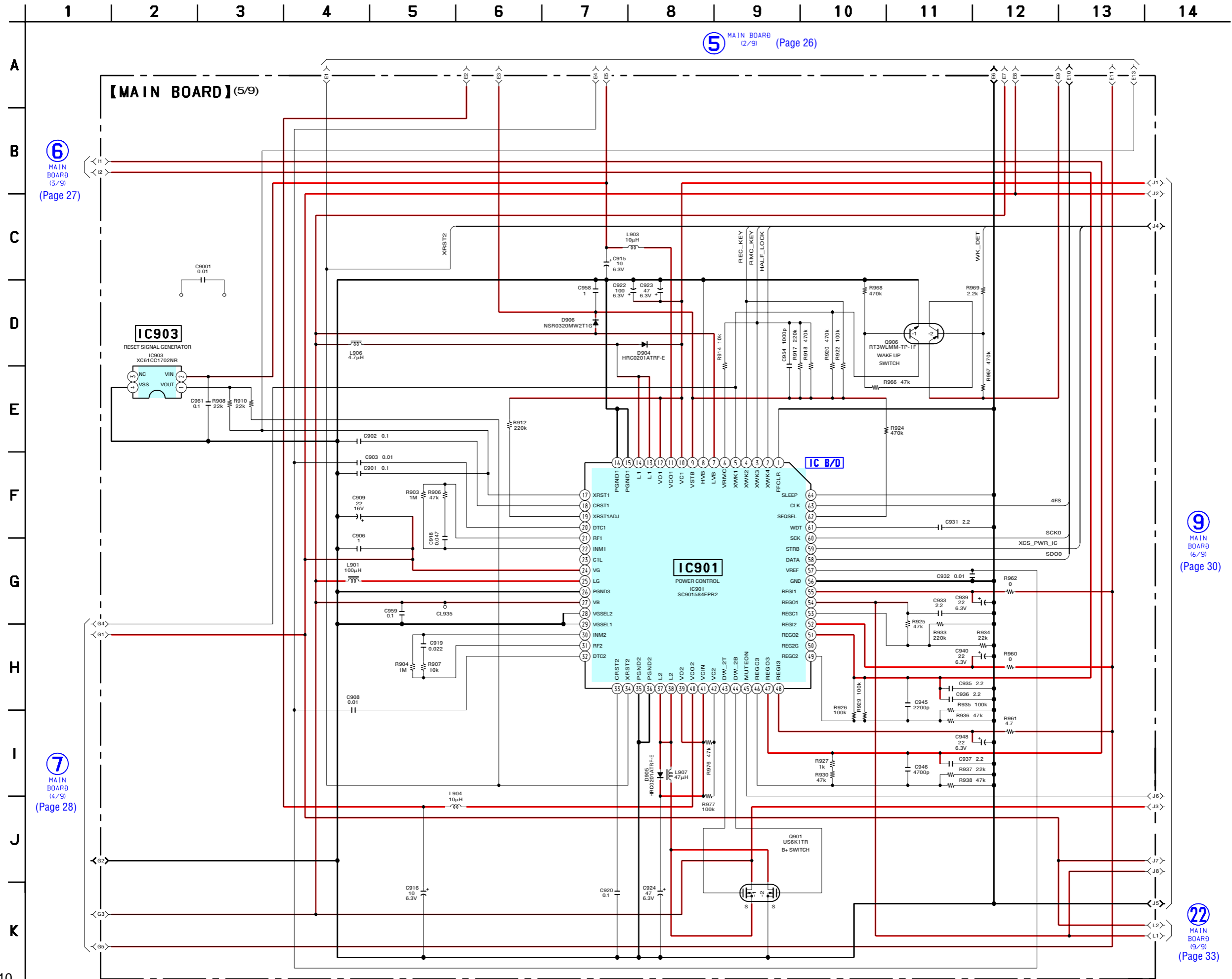

5 MAIN BOARD (2/9) (Page 26)

6 MAIN BOARD (3/9) (Page 27)

9 MAIN BOARD (6/9) (Page 30)

7 MAIN BOARD (4/9) (Page 28)

22 MAIN BOARD (9/9) (Page 33)

6-9. SCHEMATIC DIAGRAM – MAIN Board (6/9) – • See page 24 for Waveforms. • See page 36 for IC Block Diagrams.

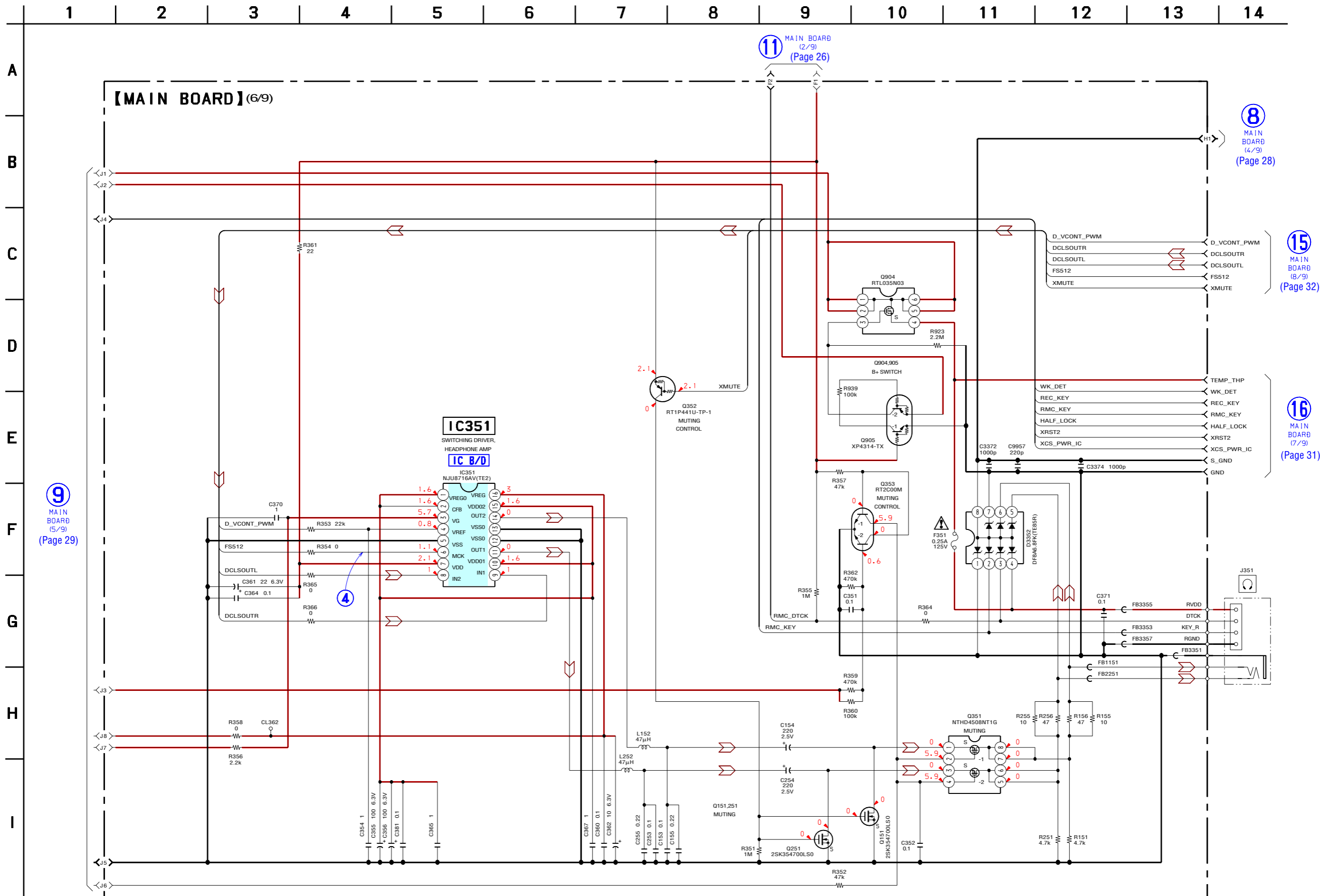

9 MAIN BOARD (5/9) (Page 29)

11 MAIN BOARD (2/9) (Page 26)

8 MAIN BOARD (4/9) (Page 28)

15 MAIN BOARD (8/9) (Page 32)

16 MAIN BOARD (7/9) (Page 31)

The components identified by mark \triangle or dotted line with mark \triangle are critical for safety. Replace only with part number specified. Les composants identifiés par une marque \triangle sont critiques pour la sécurité. Ne les remplacer que par une pièce portant le numéro spécifié.

6-10. SCHEMATIC DIAGRAM – MAIN Board (7/9) – • See page 24 for Waveforms. • See page 36 for IC Block Diagrams.

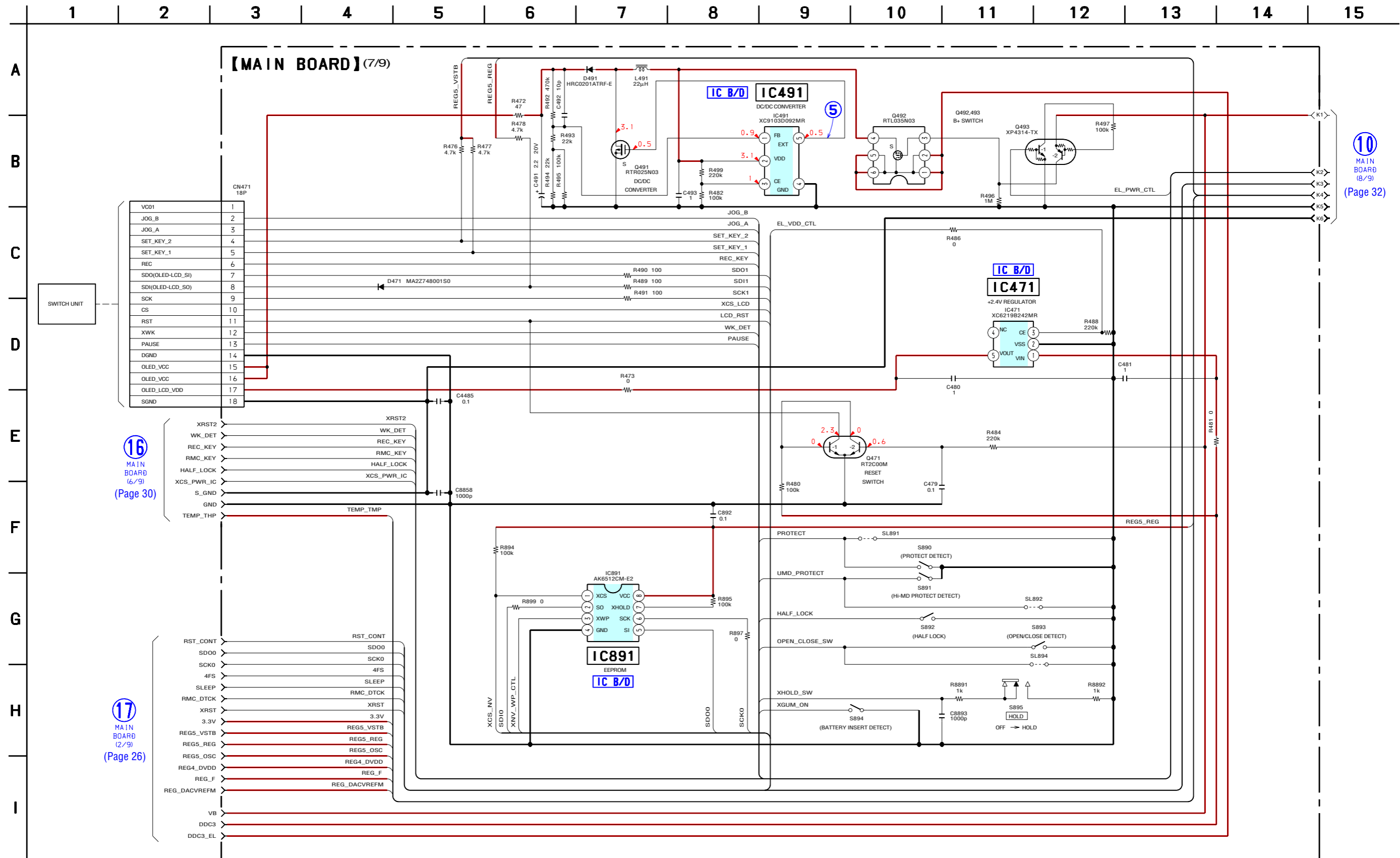

6-11. SCHEMATIC DIAGRAM – MAIN Board (8/9) – • See page 24 for Waveforms. • See page 41 for IC Pin Function Description.

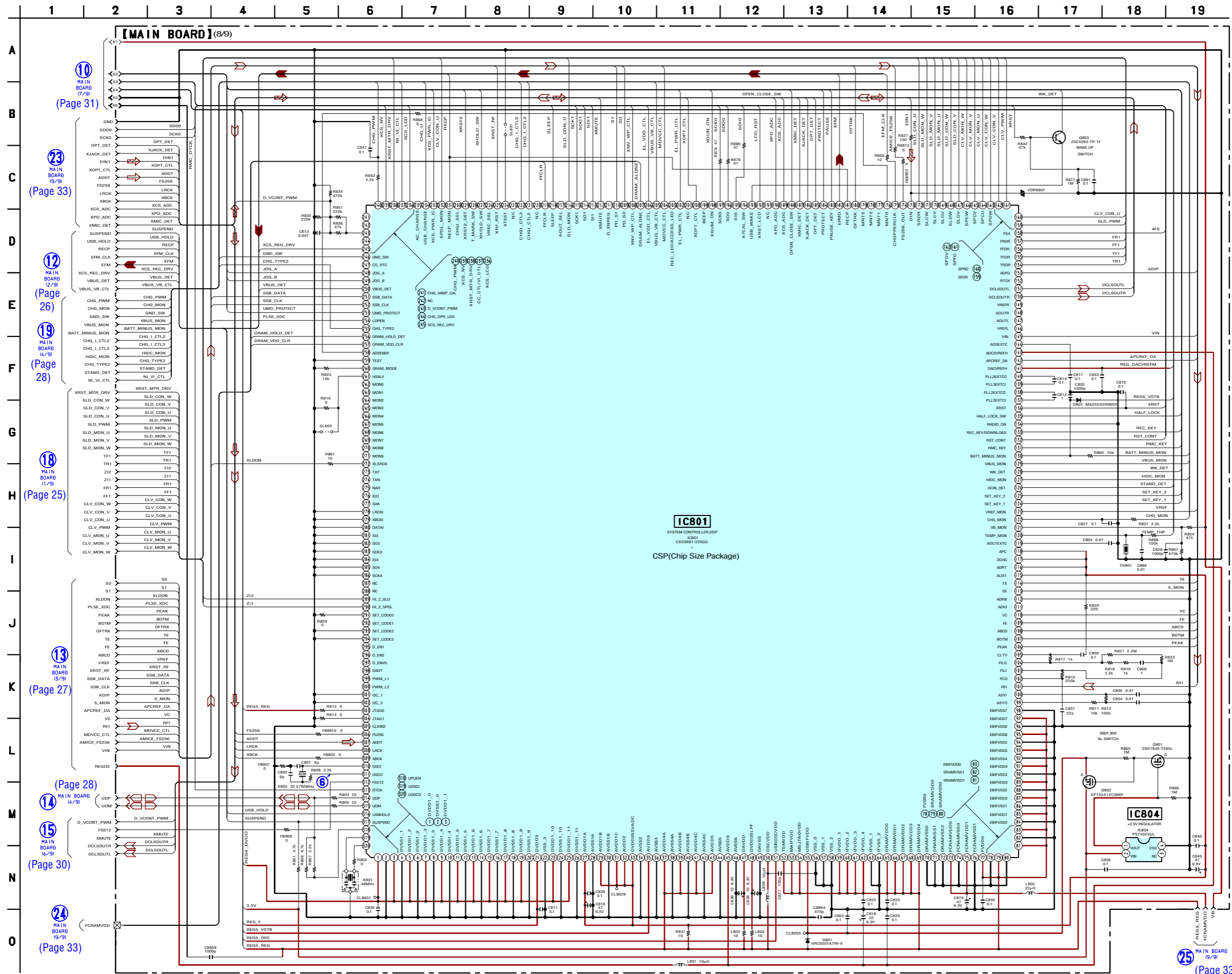

6-12. SCHEMATIC DIAGRAM – MAIN Board (9/9) – • See page 24 for Waveforms. • See page 36 for IC Block Diagrams.

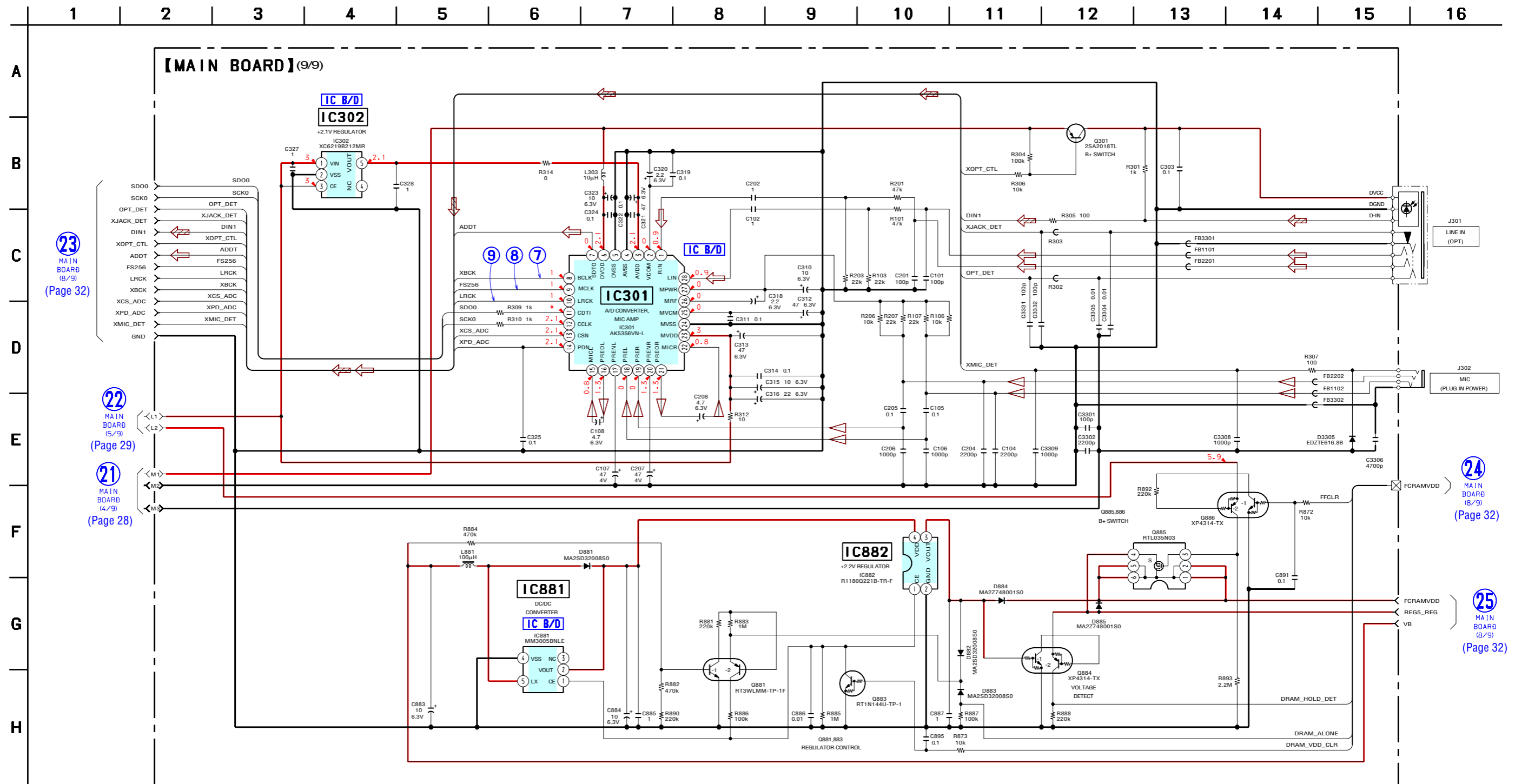

6-13. PRINTED WIRING BOARD – MAIN Board (Component Side) –  : Uses unleaded solder.

• Semiconductor Location

Ref. No.	Location
D438	H-8
D450	I-8
D458	I-5
D604	F-3
D801	H-6
D881	D-8
D882	E-7
D883	E-7
D884	E-7
D885	E-6
D904	H-4
D905	H-2
D906	H-4
D3352	G-9
D4441	D-2
IC471	H-9
IC602	F-5
IC604	F-5
IC606	G-3
IC607	F-4
IC701	E-6
IC804	I-6
IC881	E-8
IC882	E-7
IC891	F-8
IC901	H-3
IC903	I-4
Q301	D-9
Q402	H-8
Q451	J-5
Q452	I-5
Q492	J-6
Q493	I-6
Q603	H-5
Q608	F-2
Q609	H-4
Q611	F-2
Q612	H-4
Q616	F-4
Q617	G-4
Q618	F-3
Q801	I-6
Q802	H-6
Q803	G-6
Q881	D-7
Q883	F-7
Q884	E-7
Q885	E-6
Q886	F-5
Q901	G-2
Q904	I-5
Q905	I-5
Q906	J-3

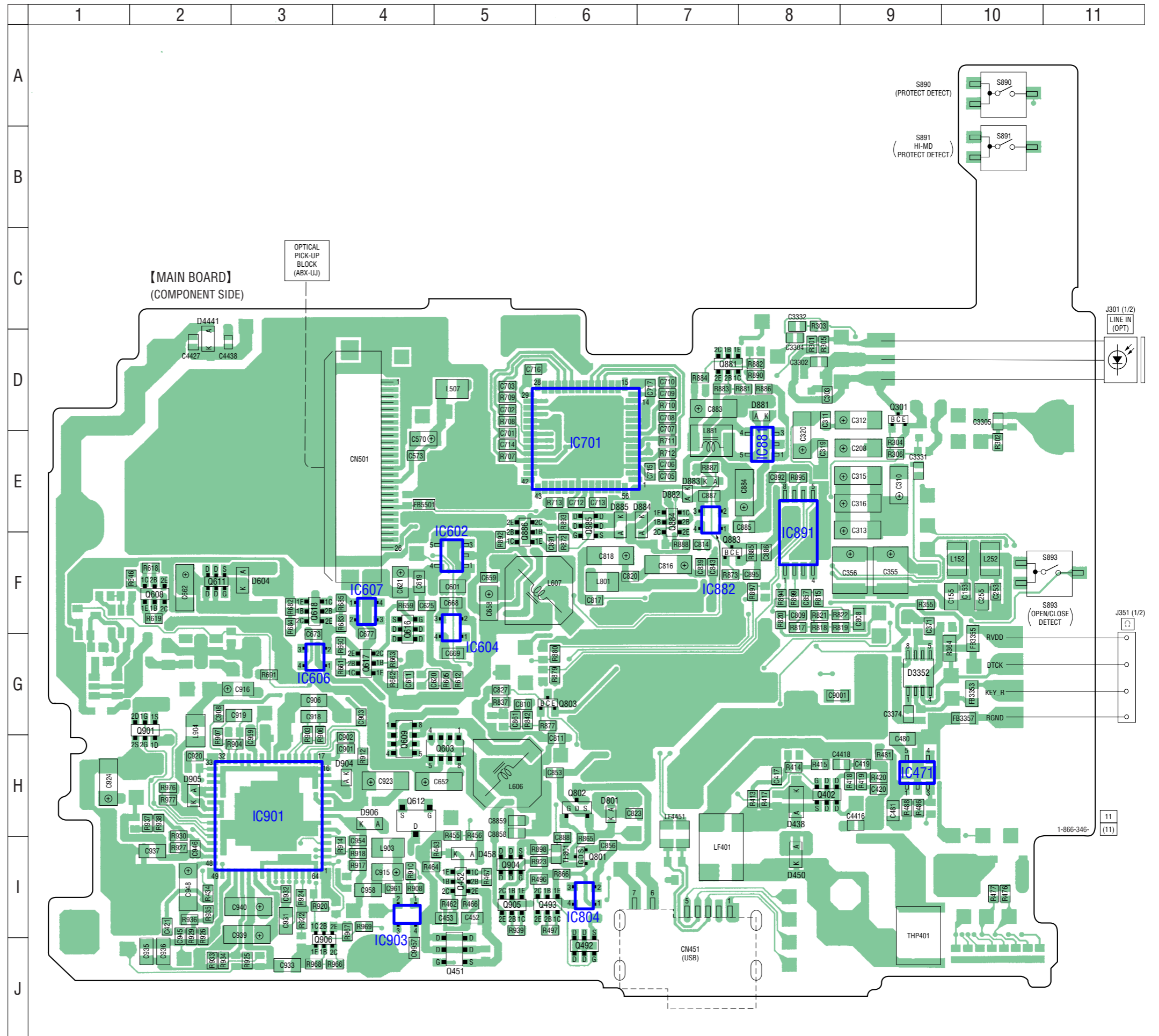

6-14. PRINTED WIRING BOARD – MAIN Board (Conductor Side) –  : Uses unleaded solder.

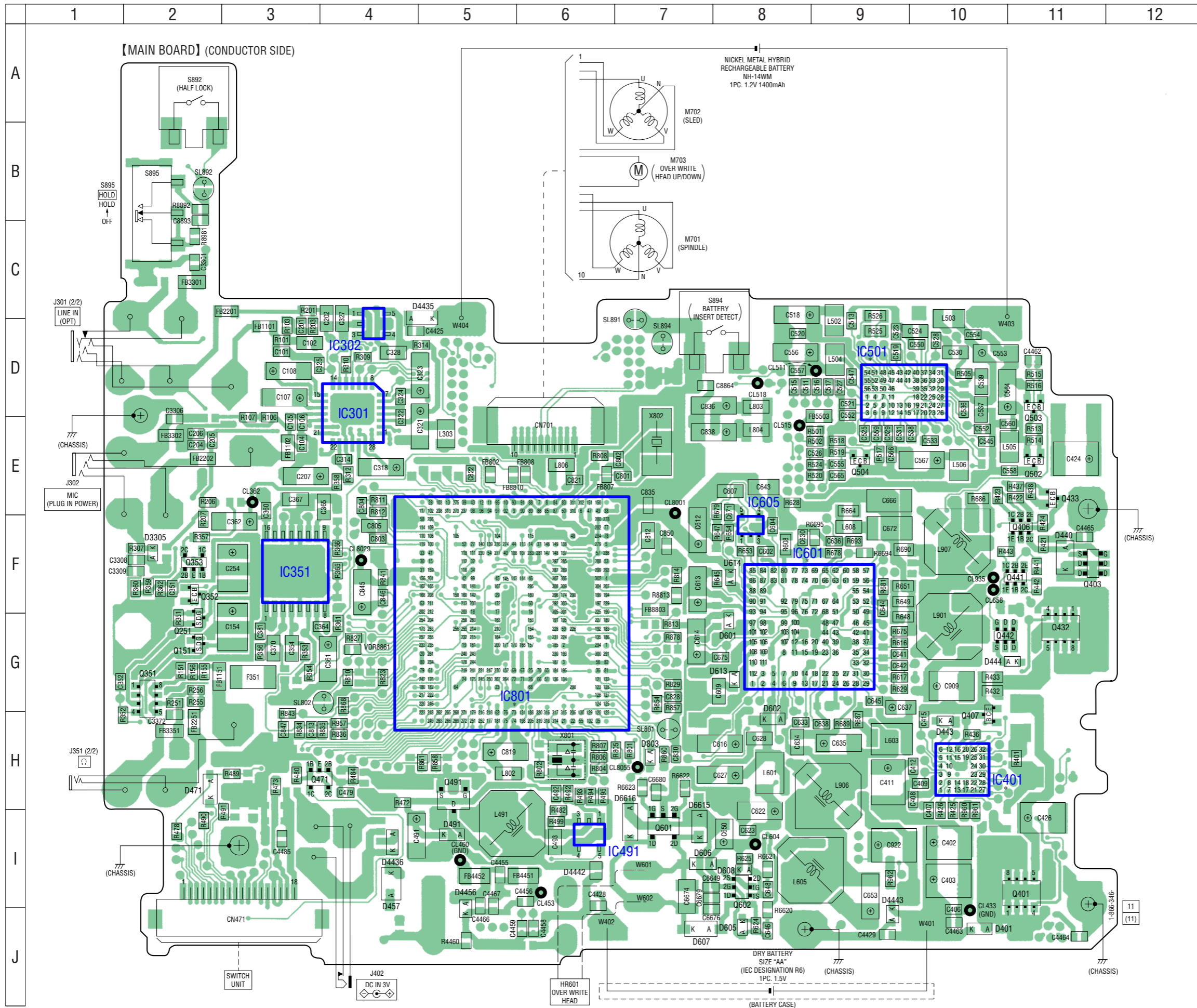

• Semiconductor Location

Ref. No.	Location
D401	J-10
D440	F-11
D443	H-10
D444	G-11
D457	I-4
D471	H-2
D491	I-5
D601	G-8
D602	H-8
D605	J-8
D606	I-7
D607	J-7
D608	I-8
D613	G-8
D614	F-8
D803	H-7
D3305	F-2
D4435	C-5
D4436	I-4
D4443	J-9
D4456	J-5
D6615	I-7
D6616	I-7
IC301	D-4
IC302	D-4
IC351	F-3
IC401	H-10
IC491	I-6
IC501	D-9
IC601	G-8
IC605	F-8
IC801	G-5
Q151	G-2
Q251	G-2
Q351	G-2
Q352	F-2
Q353	F-2
Q401	I-11
Q403	F-11
Q406	F-11
Q407	H-10
Q432	G-11
Q433	E-11
Q441	F-11
Q442	G-10
Q471	H-3
Q491	H-5
Q502	E-11
Q503	D-11
Q504	E-9
Q601	I-7
Q602	I-8

• IC Block Diagram

IC301 AK5356VN-L

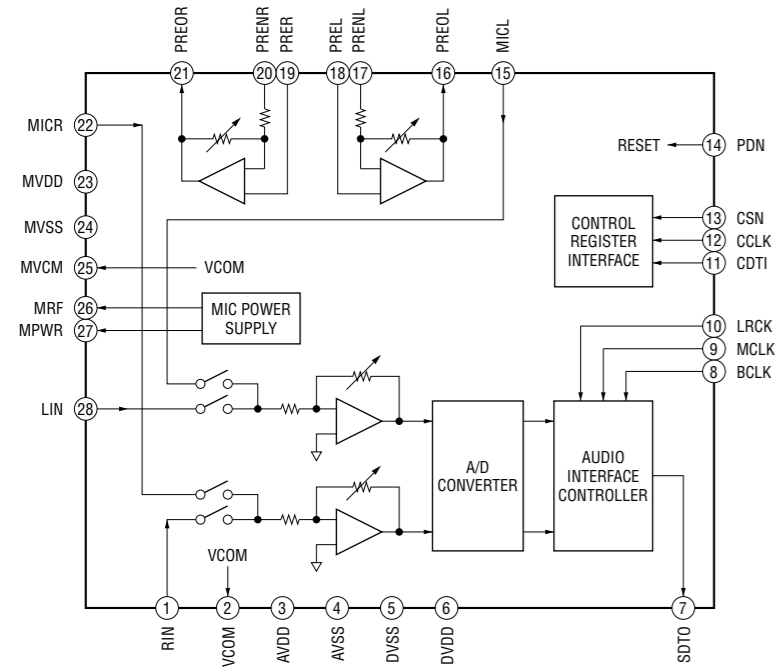

IC302 XC6219B212MR
IC471 XC6219B242MR

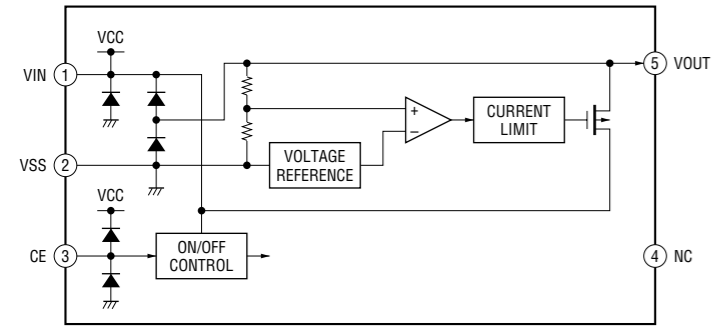

IC351 NJU8716AV (TE2)

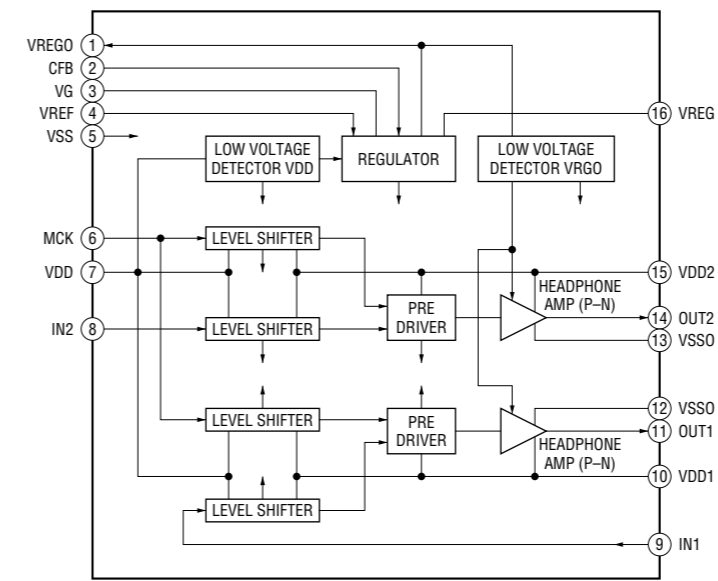

IC401 MM1690NCBE

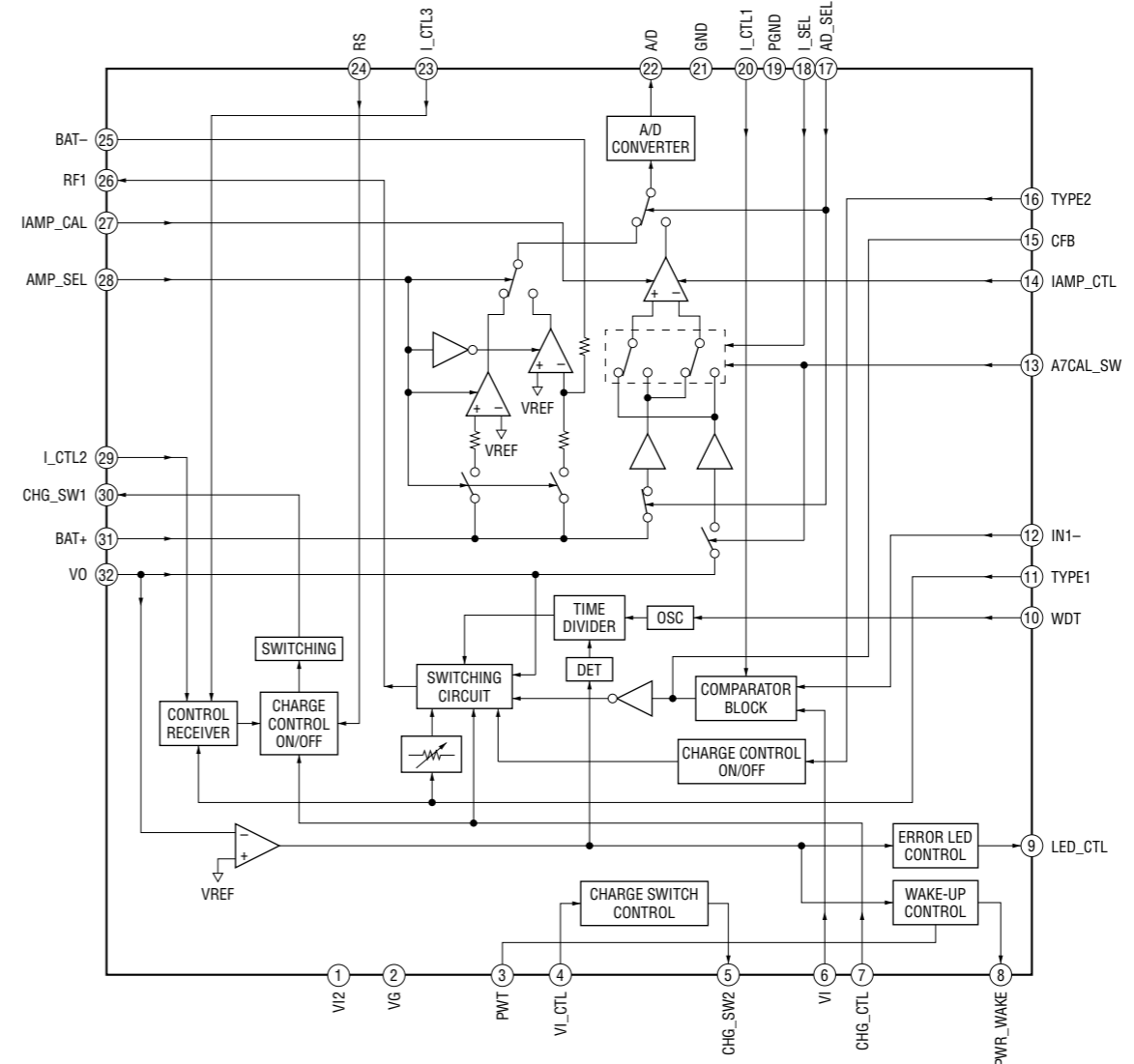

IC491 XC9103D092MR

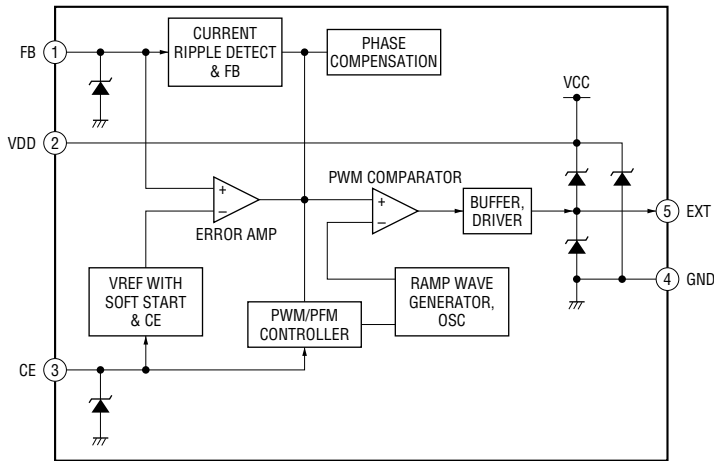

IC501 SN761059AZQLR

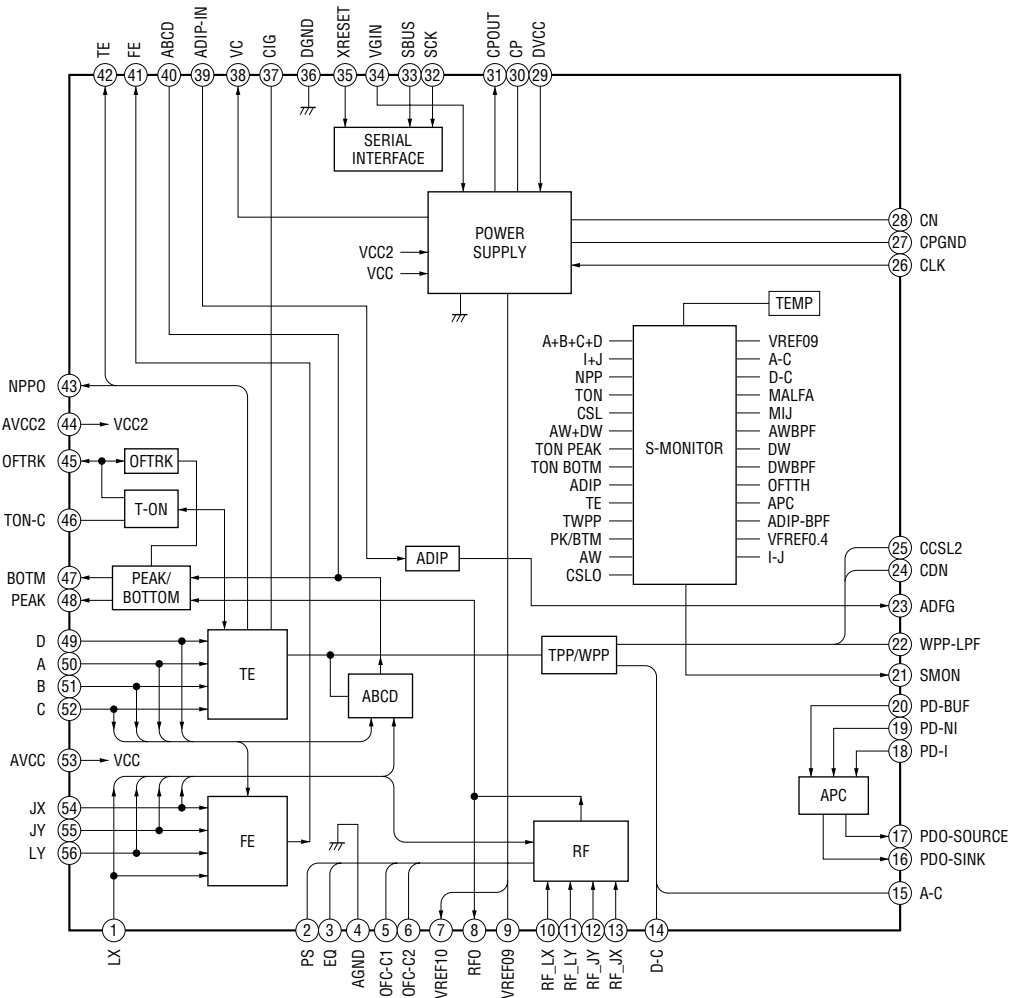

IC601 SC901585VAR2

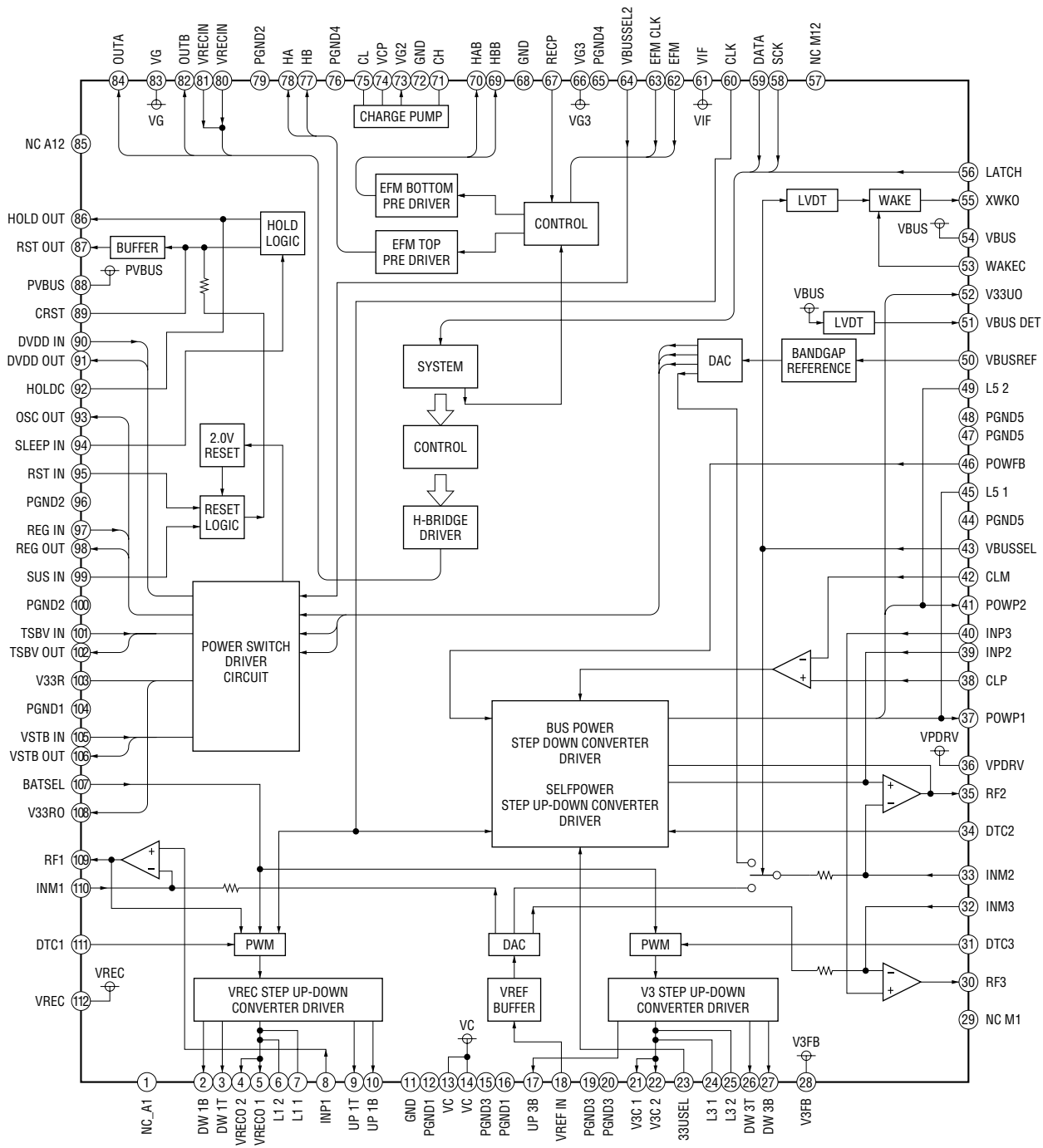

IC602 R1160N121B-TR-FA

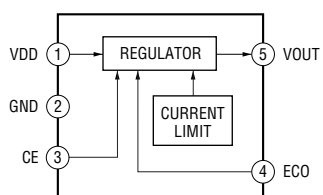

IC701 SC901583EPR2

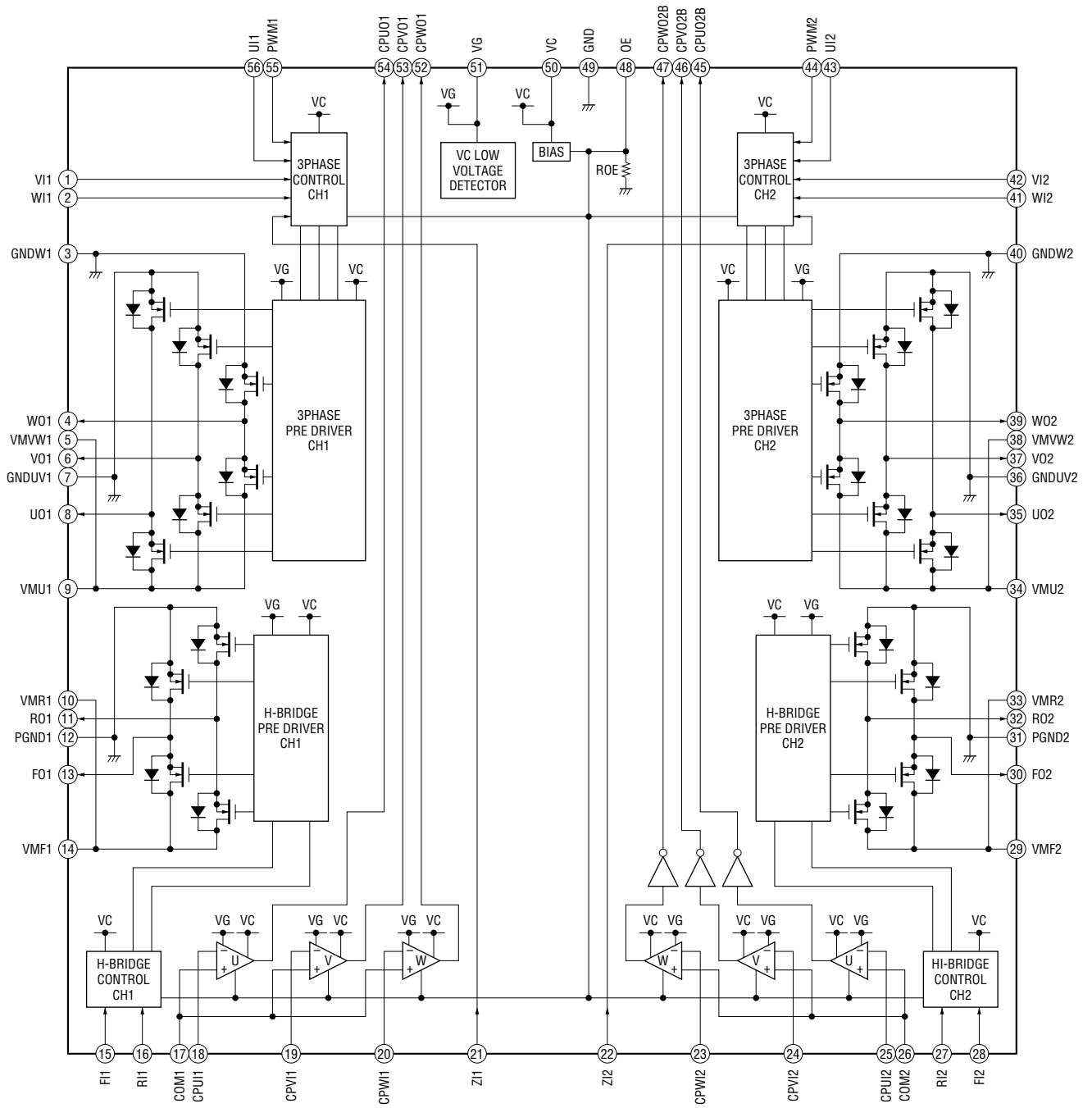

IC881 MM3005BNLE

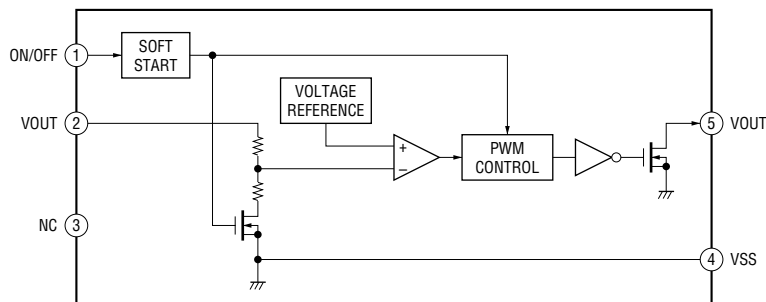

MZ-RH10

IC891 AK6512CM-E2

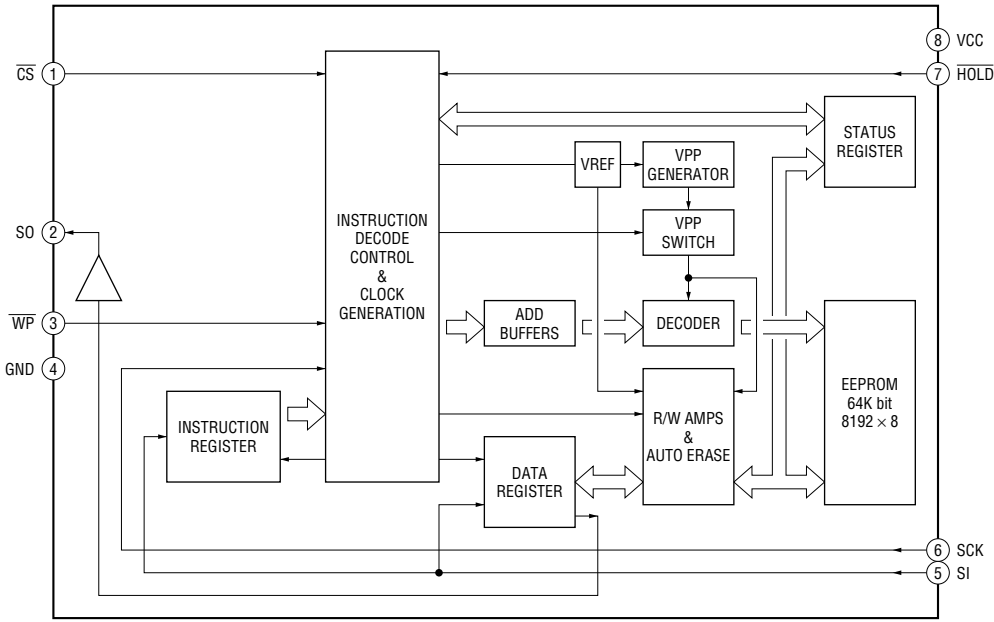

IC901 SC901584EPR2

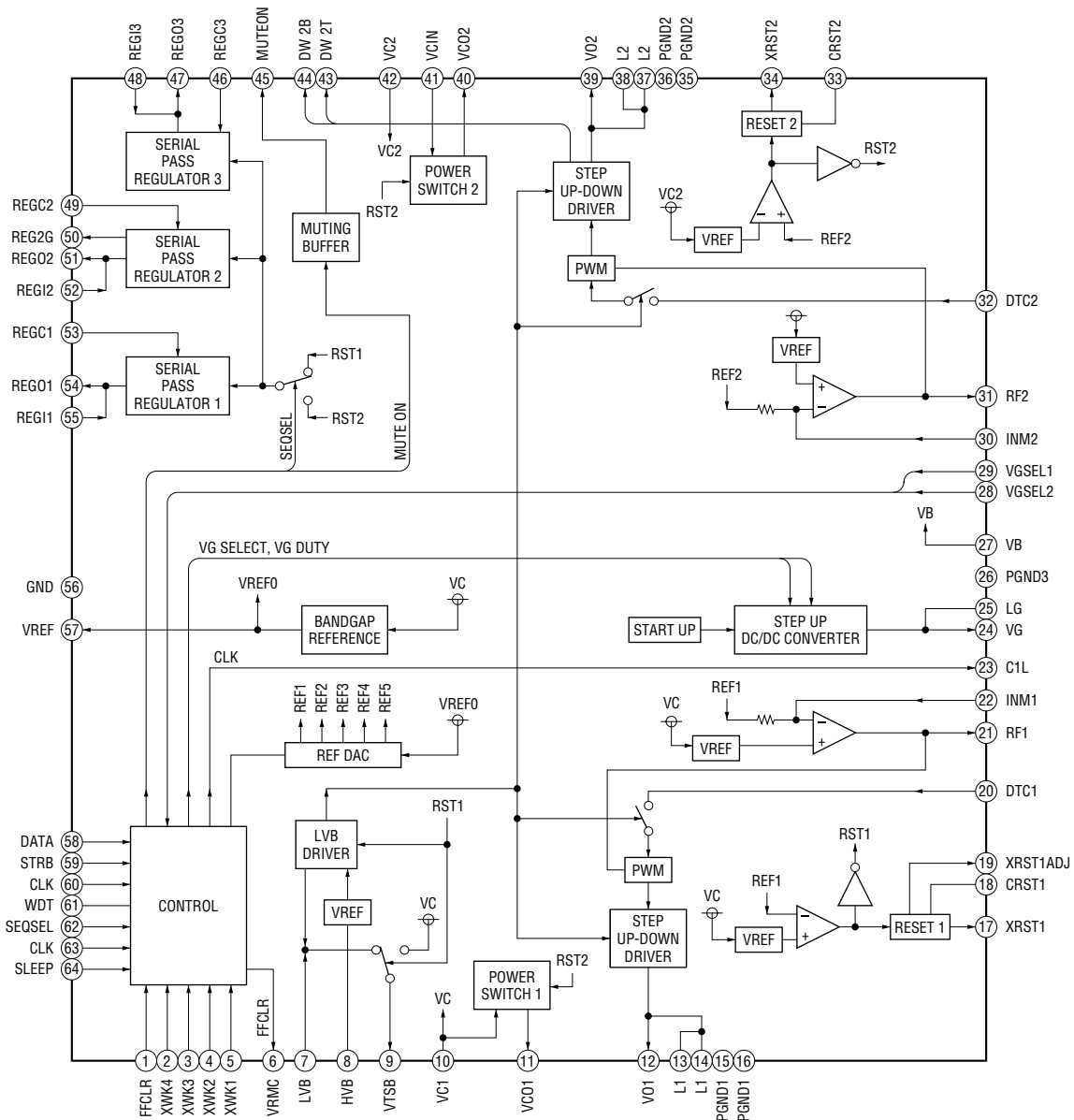

• IC PIN FUNCTION DESCRIPTION
IC801 CXD2681-225GG (SYSTEM CONTROLLER, DSP)

Pin No.	Pin Name	I/O	Description
1	DVDD1_0	-	Power supply terminal (DSP logic system)
2	DVSS1_0	-	Ground terminal (DSP logic system)
3	DVDD1_1	-	Power supply terminal (DSP logic system)
4	DVSS1_1	-	Ground terminal (DSP logic system)
5	DVDD1_2	-	Power supply terminal (DSP logic system)
6	DVSS1_2	-	Ground terminal (DSP logic system)
7	DVDD1_3	-	Power supply terminal (DSP logic system)
8	DVSS1_3	-	Ground terminal (DSP logic system)
9	DVDD1_4	-	Power supply terminal (DSP logic system)
10	DVSS1_4	-	Ground terminal (DSP logic system)
11	DVDD1_5	-	Power supply terminal (DSP logic system)
12	DVSS1_5	-	Ground terminal (DSP logic system)
13	DVDD1_6	-	Power supply terminal (DSP logic system)
14	DVSS1_6	-	Ground terminal (DSP logic system)
15	DVDD1_7	-	Power supply terminal (DSP logic system)
16	DVSS1_7	-	Ground terminal (DSP logic system)
17	DVDD1_8	-	Power supply terminal (DSP logic system)
18	DVSS1_8	-	Ground terminal (DSP logic system)
19	DVDD1_9	-	Power supply terminal (DSP logic system)
20	DVSS1_9	-	Ground terminal (DSP logic system)
21	DVDD3	-	Power supply terminal (DSP logic system)
22	VSS_3	-	Ground terminal (DSP logic system)
23	DVDD1_10	-	Power supply terminal (DSP logic system)
24	DVSS1_10	-	Ground terminal (DSP logic system)
25	DVDD1_11	-	Power supply terminal (DSP logic system)
26	DVSS1_11	-	Ground terminal (DSP logic system)
27	AVDD1A	-	Power supply terminal (for PLL)
28	AVSS1A	-	Ground terminal (for PLL)
29	AVDD1B	-	Power supply terminal (for RFA of asymmetry correction cell)
30	AVSS1B	-	Ground terminal (for RFA of asymmetry correction cell)
31	AVDD1C	-	Power supply terminal (for ASYO of asymmetry correction cell)
32	AVDD2	-	Power supply terminal (for A/D converter)
33	DVDD25SVADC	-	Power supply terminal (for A/D converter)
34	AVSS2	-	Ground terminal (for A/D converter)
35	AVDD3	-	Power supply terminal (for A/D converter)
36	AVSS3	-	Ground terminal (for A/D converter)
37	AVDD4A	-	Power supply terminal (for PLL)
38	AVSS4A	-	Ground terminal (for PLL)
39	AVDD4B	-	Power supply terminal (for PLL)
40	AVSS4B	-	Ground terminal (for PLL)
41	AVDD4C	-	Power supply terminal (for D/A converter)
42	AVSS4C	-	Ground terminal (for D/A converter)
43	AVDD5	-	Power supply terminal (for PLL)
44	AVSS5	-	Ground terminal (for PLL)
45	AVDD6	-	Power supply terminal (for A/D converter)
46	AVSS6	-	Ground terminal (for A/D converter)

Pin No.	Pin Name	I/O	Description
47	DAVDD	-	Power supply terminal (for D/A converter)
48	DVDD25LPF	-	Power supply terminal (for D/A converter)
49	DAVSS	-	Ground terminal (for D/A converter)
50	OSCVDD	-	Power supply terminal (for 22.5792 MHz OSC)
51	USBOSCVDD	-	Power supply terminal (for the USB 48 MHz OSC)
52	TSMVDD	-	Power supply terminal (for the TSB master communication)
53	MAIFVDD	-	Power supply terminal (for MA interface)
54	MSJTAGVDD	-	Power supply terminal (for MS interface and JTAG)
55	USBIFVDD	-	Power supply terminal (for USB interface)
56 to 58	VSS_0 to VSS_2	-	Power supply terminal (for 22.5792 MHz OSC, USB 48 MHz OSC, TSB master communication, MS interface, MA interface, JTAG and USB interface)
59 to 62	IFVDD_1 to IFVDD_4	-	Power supply terminal (for interface)
63, 64	IFVSS_1, IFVSS_2	-	Ground terminal (for interface)
65 to 69	DRAMVDD0 to DRAMVDD4	-	Power supply terminal (for D-RAM/DSP interface)
70 to 72	DRAMVSS0 to DRAMVSS2	-	Ground terminal (for D-RAM/DSP interface)
73	FCRAMVDD0	-	Power supply terminal (for D-RAM)
74	FCRAMVSS0	-	Ground terminal (for D-RAM)
75	FCRAMVDD1	-	Power supply terminal (for D-RAM)
76	FCRAMVSS1	-	Ground terminal (for D-RAM)
77	FVDD0	-	Power supply terminal (for flash memory)
78	FVSS0	-	Ground terminal (for flash memory)
79	SRAMVDD0	-	Power supply terminal (for S-RAM)
80	SRAMVSS0	-	Ground terminal (for S-RAM)
81	SRAMVDD1	-	Power supply terminal (for S-RAM)
82	SRAMVSS1	-	Ground terminal (for S-RAM)
83	EBIFVDD0	-	Power supply terminal (for external flash memory bus interface)
84	EBIFVSS0	-	Ground terminal (for external flash memory bus interface)
85	EBIFVDD1	-	Power supply terminal (for external flash memory bus interface)
86	EBIFVSS1	-	Ground terminal (for external flash memory bus interface)
87	EBIFVDD2	-	Power supply terminal (for external flash memory bus interface)
88	EBIFVSS2	-	Ground terminal (for external flash memory bus interface)
89	EBIFVDD3	-	Power supply terminal (for external flash memory bus interface)
90	EBIFVSS3	-	Ground terminal (for external flash memory bus interface)
91	EBIFVDD4	-	Power supply terminal (for external flash memory bus interface)
92	EBIFVSS4	-	Ground terminal (for external flash memory bus interface)
93	EBIFVDD5	-	Power supply terminal (for external flash memory bus interface)
94	EBIFVSS5	-	Ground terminal (for external flash memory bus interface)
95	EBIFVDD6	-	Power supply terminal (for external flash memory bus interface)
96	EBIFVSS6	-	Ground terminal (for external flash memory bus interface)
97	EBIFVDD7	-	Power supply terminal (for external flash memory bus interface)
98	EBIFVSS7	-	Ground terminal (for external flash memory bus interface)
99	ASYO	O	Playback EFM duplex signal output terminal
100	ASYI	I	Playback EFM comparator slice level input terminal
101	RFI	I	Playback EFM RF signal input from the RF amplifier
102	PCO	O	Phase comparison output terminal for the playback EFM system master PLL

Pin No.	Pin Name	I/O	Description
103	FILI	I	Filter input terminal for the playback EFM system master PLL
104	FILO	O	Filter output terminal for the playback EFM system master PLL
105	CLTV	I	Internal VCO control voltage input terminal for the playback EFM system master PLL
106	PEAK	I	Peak hold signal input of the light amount signal (RF/ABCD) the RF amplifier
107	BOTM	I	Bottom hold signal input of the light amount signal (RF/ABCD) the RF amplifier
108	ABCD	I	Light amount signal (ABCD) input from the RF amplifier
109	FE	I	Focus error signal input from the RF amplifier
110	VC	I	Middle point voltage input from the RF amplifier
111	ADIO	I	Monitor output terminal of A/D converter input signal Not used
112	ADRB	I	A/D converter the lower limit voltage input terminal
113	SE	I	Sled error signal input from the RF amplifier
114	TE	I	Tracking error signal input from the RF amplifier
115	AUX1	I	Auxiliary A/D input terminal
116	ADRT	I	The upper limit voltage of A/D converter input terminal
117	DCHG	-	Connecting terminal with the analog power supply of low impedance
118	APC	I	Error signal input terminal for the laser automatic power control
119	ADC1EXTC	-	Connection terminal for an external capacitor
120	TEMP_MON	I	Thermistor connection terminal for temperature detection
121	VB_MON	I	Monitor input terminal of rechargeable battery power supply voltage (UNREG)
122	CHG_MON	I	Charge or discharge current monitor input from power control IC
123	VREF_MON	O	Reference voltage monitor input from the RF amplifier
124, 125	SET_KEY_1, SET_KEY_2	I	Set key input terminal (A/D input)
126	DCIN_DET	I	Monitor input terminal of DC input voltage for battery charge
127	HIDC_MON	I	Monitor input terminal of High DC voltage
128	WK_DET	I	Detection terminal of panel key input for system wake up
129	VBUS_MON	I	Detection terminal of panel key input for camera wake up
130	BATT_MINUS _MON	I	Monitor input terminal of USB power supply voltage (VBUS)
131	RMC_KEY	I	Monitor input terminal of rechargeable battery minus terminal voltage
132	RST_CONT	O	Reset signal output to the power control IC
133	REC_KEY/ DOWNLOAD	I	REC/T MARK key input terminal
134	RADIO_ON	I	Radio on detection input terminal Not used
135	HALF_LOCK_SW	I	Top panel open switch detection terminal
136	XRST	I	System reset signal input terminal
137	PLL2EXTCI	I	Connection terminal for an external capacitor
138	PLL2EXTCO	O	Connection terminal for an external capacitor
139	PLL3EXTCI	I	Connection terminal for an external capacitor
140	PLL3EXTCO	O	Connection terminal for an external capacitor
141	DACVREFH	I	Reference voltage input terminal
142	APCREF_DA	O	Reference voltage output to the RF amplifier
143	ADC3VREFH	I	Reference voltage input terminal
144	ADC3EXTC	-	Connection terminal for an external capacitor (for A/D converter)
145	VIN	I	RF signal input from the RF amplifier
146	VREFL	I	Reference voltage input terminal (for internal D/A converter L-CH) Not used
147	AOUTL	O	Internal D/A converter (L-CH) output terminal Not used
148	AOUTR	O	Internal D/A converter (R-CH) output terminal Not used

Pin No.	Pin Name	I/O	Description
149	VREFR	I	Reference voltage input terminal (for internal D/A converter R-CH) Not used
150	DCLSOUTR	O	PWM modulator signal output to the headphone amplifier (R-CH)
151	DCLSOUTL	O	PWM modulator signal output to the headphone amplifier (L-CH)
152	RTCK	O	Not used
153	ADFG	I	ADIP duplex FM signal (21.05kHz to 23.05 kHz) input from the RF amplifier
154	TRDR	O	Tracking servo drive PWM signal output (-) to the coil driver
155	TFDR	O	Tracking servo drive PWM signal output (+) to the coil driver
156	FFDR	O	Focus servo drive PWM signal output (+) to the coil driver
157	FRDR	O	Focus servo drive PWM signal output (-) to the coil driver
158	FS4	O	176.4 kHz clock signal output to the over write head driver and power control IC
159	SFDR	O	Sled servo drive PWM signal output to the motor driver
160	SPRD	O	Spindle motor drive control signal output (U) to the motor driver
161	SPFD	O	Spindle servo drive PWM signal output to the motor driver
162	SPDV	O	Spindle motor drive control signal output (V) to the motor driver
163	SPDW	O	Spindle motor drive control signal output (W) to the motor driver
164	SPCU	I	Spindle motor drive comparison signal input (U) from the motor driver
165	SPCV	I	Spindle motor drive comparison signal input (V) from the motor driver
166	SPCW	I	Spindle motor drive comparison signal input (W) from the motor driver
167	SLDV	O	Sled motor drive control signal output (V) to the motor driver
168	SLDW	O	Sled motor drive control signal output (W) to the motor driver
169	SLCU	I	Sled motor drive comparison signal input (U) from the motor driver
170	SLCV	I	Sled motor drive comparison signal input (V) from the motor driver
171	SLCW	I	Sled motor drive comparison signal input (W) from the motor driver
172	SRDR	O	Sled motor drive control signal output (U) to the motor driver
173	DIN	I	Digital audio signal input terminal
174	FS256_OUT	O	11.2896 MHz clock output to the RF amplifier
175	CHOPPERCLK	O	Clock signal output for chopper to the over write head driver
176 to 179	MNT0 to MNT3	O	Monitor output terminal for DSP Not used
180	OFTRK	I/O	Tracking signal input/output for MD3
181	RECP	O	Laser power selection signal output to the power control IC
182	EFMO	O	EFM encode data output for the recording to the over write head driver
183	PAUSE_KEY	I	Pause key input terminal
184	PROTECT	I	Recording protector for normal disc detection switch input terminal
185	OPT_DET	I	Optical digital input plug detection signal input terminal "H": optical in
186	XJACK_DET	I	Line input plug detection signal input terminal "L": plug in
187	XMIC_DET	I	Microphone input plug detection signal input terminal "L": plug in
188	OPEN_CLOSE_SW	I	Top panel open/close detection switch input terminal
189	XCS_ADC	O	Chip select signal output to the A/D converter
190	XPD_ADC	O	Power control signal output to the A/D converter
191	NC	-	Not used
192	XRST_LCD	O	Reset signal output to the switch unit
193	USB_WAKE	I	System wake up signal output terminal by USB connection
194	A7CAL_SW	I/O	A7 offset voltage CAL on/off control signal output terminal Not used
195	SI0	I	Serial data input from the EEPROM
196	SO0	O	Serial data output to the A/D converter, EEPROM and power control IC
197	SCK0	O	Serial data transfer clock signal output to the A/D converter, EEPROM and power control IC
198	XGUM_ON	I	Rechargeable battery insert detection switch input terminal

Pin No.	Pin Name	I/O	Description
199	BEEP	O	Beep sound control signal output to the headphone amplifier Not used
200	XOPT_CTL	O	Power supply on/off control signal output terminal for the optical input jack
201	NC	-	Not used
202	EL_PWR_CTL	O	EL power supply on/off control signal output terminal
203	REC_LED/ ACCESS_LED	O	Recording indication LED and accessing indication LED drive signal output terminal Not used
204	MDVCC_CTL	O	Power supply control signal output terminal for the optical pick-up block
205	VBUS_VB_CTL	O	USB power supply control signal output terminal
206	EL_PWR_CTL	O	EL VDD power supply on/off control signal output terminal
207	DRAM_ALONE	O	Power on/off control signal output terminal for internal D-RAM
208	XNV_WP_CTL	-	Write protect signal output to the EEPROM
209, 210	PD_S0, PD_S1	O	PD IC mode selection signal output to the optical pick-up block
211	D_ENREG	O	Internal power supply on/off control signal output to the headphone amplifier
212	XMUTE	O	Muting on/off control signal output terminal
213	SII	I	Serial data input from the switch unit
214	SOI	O	Serial data output to the switch unit
215	SCK1	O	Serial data transfer clock signal output to the switch unit
216	SLD_MON	I	Monitor signal input terminal of sled servo
217	AOUT_SEL	O	Headphone/line output selection signal output terminal Not used
218	SLEEP	O	Chip enable signal output to the power control IC
219	FFCLR	O	Power supply on/off control signal output terminal for FCRAM (internal RAM)
220	NC	-	Not used
221, 222	CHGI_CTL2, CHGI_CTL3	O	Charge current control signal output terminal "H": low current charge
223	NC	-	Not used
224	XTEST	I	Input terminal for the test mode setting "L": test mode
225	XRF_RST	O	Reset signal output to the RF amplifier
226	VREC_SEL	O	VREC wake up timing control signal output terminal Not used
227	XHOLD_SW	I	HOLD switch input terminal
228	T_MARK_SW	I	T MARK switch input terminal Not used
229	XRST2_DET	I	Reset signal input from the power control IC
230	CHGI_SEL	O	Charge/discharge control signal output for current detection amplifier to the charge control IC
231	RECP_MON	I	Monitor input terminal for laser power selection signal output
232	SPDL_MON	I	Monitor signal input terminal of spindle servo
233	XCS_PWR_IC	O	Chip select signal output to the power control IC
234	USB_CHARGE	O	USB charge control signal output terminal
235	AC_CHARGE	O	AC charge control signal output terminal Not used
236	XCS_LCD	O	Chip select signal output to the switch unit
237	CC_CTL/VI_CTL	O	Constant current circuit control signal output to the charge control IC
238	XRST_MTR_DRV	O	Reset signal output to the motor driver
239	XCS_NV	O	Chip select signal output to the EEPROM
240	CHG_PWM	O	Charge current or voltage control signal output to the charge control IC
241	IAMP_CAL	O	Offset signal output for current detection amplifier charge control IC Not used
242	NC	-	Not used
243	D_VCONT_PWM	O	For voltage control signal output to the headphone amplifier
244	CHG_OPR_LED	O	Charging indication LED drive signal output terminal
245	XCS_REC_DRV	O	Chip select signal output to the over write head driver
246	GND_SW	O	Ground line selection signal output terminal

Pin No.	Pin Name	I/O	Description
247	CS_RTC	O	Chip select signal output to the real time clock Not used
248	JOG_A	I	Jog dial pulse input terminal (A phase)
249	JOG_B	I	Jog dial pulse input terminal (B phase)
250	VBUS_DET	I	Detection terminal of USB power supply
251	SSB_DATA	I/O	SSB data input/output with the RF amplifier
252	SSB_CLK	O	SSB clock output to the RF amplifier
253	UMD_PROTECT	I	Recording protector for Hi-MD disc detection switch input terminal
254	LDPEN	O	Pulse/DC light-emit selection signal output to the optical pick-up block
255	CHG_TYPE2	O	Charge control signal output terminal "H": charging
256	DRAM_HOLD_DET	I	Detection terminal for internal D-RAM power supply information keeping
257	DRAM_VDD_CLR	O	Internal D-RAM power supply latch clear signal output for quick mode sleep
258	AD2ENDF	I	Monitor input terminal for flag of servo signal A/D measuring finish
259	TEST	I	Input terminal for the test Not used
260	SRAM_MODE	I	Terminal for setting
261	HSALF	I	Terminal for setting
262 to 271	MON0 to MON9	O	Trigger monitor terminal Output clock=18.5 MHz
272	XLSRCK	O	Pulse output for laser strobe recording to the optical pick-up
273	TAT	I	Not used
274	TAN	I	Not used
275	NAR	I	Not used
276	IDO	I	Not used
277	SAK	O	Not used
278	LRCKI	I	L/R sampling clock signal input terminal for PCM data interface Not used
279	XBCKI	I	Bit clock signal input terminal for the PCM data interface Not used
280	DATAI	I	Serial data input terminal for the PCM data interface Not used
281	SI3	I	Serial data input for LAM microcomputer communication Not used
282	SO3	O	Serial data output for LAM microcomputer communication Not used
283	SCK3	O	Serial data transfer clock signal output for LAM microcomputer communication Not used
284	SI4	I	Serial data input for ATRAC3 plus encoder communication Not used
285	SO4	O	Serial data output for ATRAC3 plus encoder communication Not used
286	SCK4	O	Serial data transfer clock signal output for ATRAC3 plus encoder communication Not used
287, 288	NC	-	Not used
289	HI_Z_SLD	O	Standby signal output for the sled motor to the motor driver
290	HI_Z_SPDL	O	Standby signal output for the spindle motor to the motor driver
291 to 294	SET_CODE0 to SET_CODE3	I	Input terminal for the model setting
295, 296	D_EN1, D_EN2	O	Headphone/LINE/beep selection signal output to the headphone amplifier Not used
297	D_ENVG	O	Power on/off control signal output terminal for headphone amplifier
298	DADT	O	Audio data output to the D/A converter Not used
299, 300	PWM_L1, PWM_L2	O	LC drive PWM output terminal Not used
301, 302	I2C_1, I2C_2	I/O	Open drain for I2C
303, 304	JTAG0, JTAG1	I/O	Terminal for setting
305	CLKIN2	I	Clock signal input terminal (13.5 MHz or 27 MHz) Not used
306	FS256	O	Master clock signal (256Fs=11.2896 MHz) output to A/D converter
307	ADDT	I	Data input from A/D converter
308	LRCK	O	L/R sampling clock signal (44.1kHz) output to external A/D converter

Pin No.	Pin Name	I/O	Description
309	XBCK	O	Bit clock (2.8224 MHz) output to the external A/D converter
310	OSCI	I	Main system clock input terminal (22.5792 MHz)
311	OSCO	O	Main system clock output terminal (22.5792 MHz)
312	FS512	O	Clock signal (512Fs=22.5792 MHz) output to the headphone amplifier
313	DTCK	I/O	TSB master data clock input/output or SSB data input/output with the remote commander
314	UDP	I/O	USB data (+) input/output terminal
315	UDM	I/O	USB data (-) input/output terminal
316	USBHOLD	I	USB hold signal input from the power control IC
317	SUSPEND	O	USB suspend signal output to the power control IC
318	UPUEN	O	USB pull-up resistor connection control terminal
319	UOSCI	I	System clock input terminal (48 MHz) (for USB oscillation circuit)
320	UOSCO	O	System clock output terminal (48 MHz) (for USB oscillation circuit)

SECTION 7 EXPLODED VIEWS

NOTE:

- -XX and -X mean standardized parts, so they may have some difference from the original one.
- Color Indication of Appearance Parts
Example:
KNOB, BALANCE (WHITE) . . . (RED)
 ↑ ↑
 Parts Color Cabinet's Color

- Items marked “*” are not stocked since they are seldom required for routine service. Some delay should be anticipated when ordering these items.
- The mechanical parts with no reference number in the exploded views are not supplied.
- Accessories are given in the last of the electrical parts list.

The components identified by mark \triangle or dotted line with mark \triangle are critical for safety. Replace only with part number specified.

Les composants identifiés par une marque \triangle sont critiques pour la sécurité. Ne les remplacer que par une pièce portant le numéro spécifié.

7-1. CASE (LOWER) SECTION

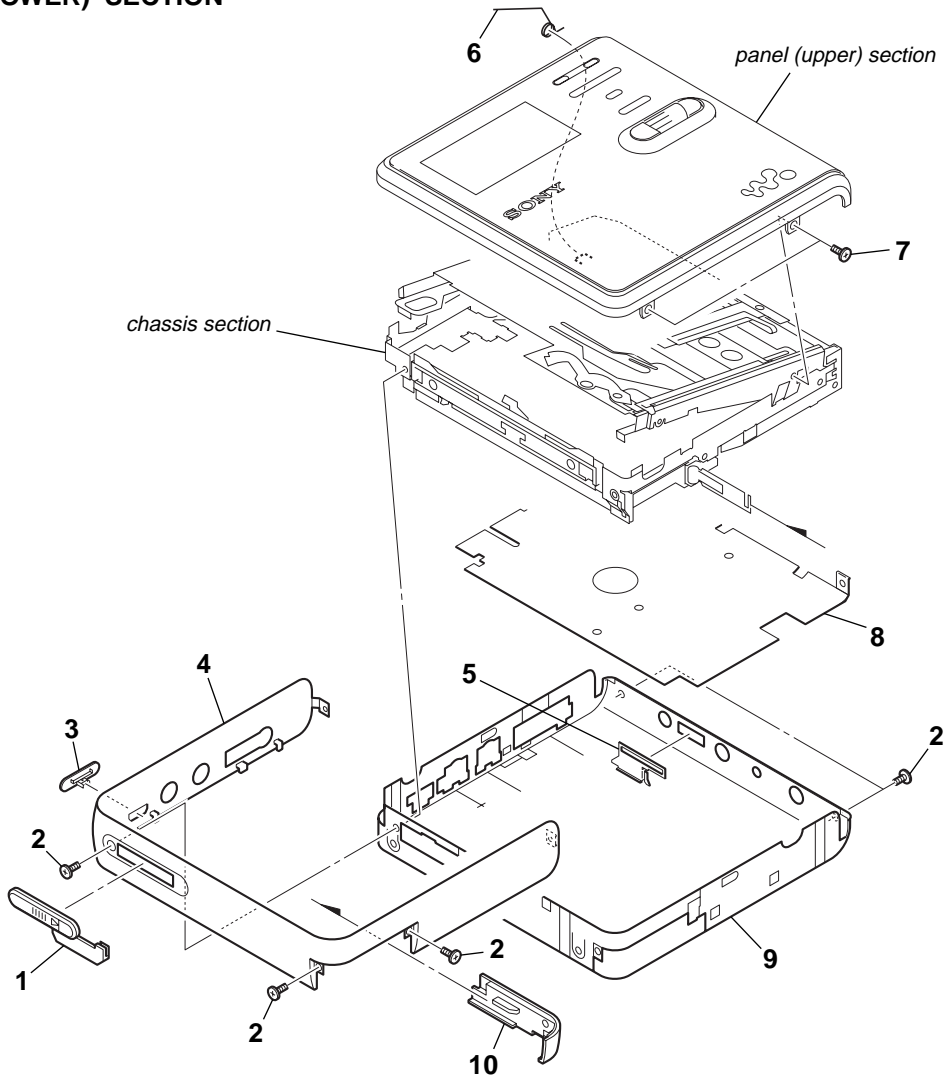

Ref. No.	Part No.	Description	Remark	Ref. No.	Part No.	Description	Remark
1	2-588-293-01	KNOB (OPEN) (for BLACK)		5	2-593-171-01	SHUTTER (JACK)	
1	2-588-293-11	KNOB (OPEN) (for SILVER)		6	2-588-274-01	TORSION SPRING (L)	
1	2-588-293-21	KNOB (OPEN) (for BLUE)		7	3-234-449-19	SCREW (M1.4)	
1	2-588-293-41	KNOB (OPEN) (for ORANGE)		8	X-2055-749-1	SHEET EMC SV ASSY	
2	3-234-449-25	SCREW (M1.4) (for BLACK)		9	2-588-290-81	CASE (LOWER) (BLACK)	
2	3-234-449-27	SCREW (M1.4) (for SILVER, BLUE, ORANGE)		9	2-588-290-91	CASE (LOWER) (SILVER)	
3	3-237-092-01	KNOB (HOLD) (for SILVER)		9	2-629-174-01	CASE (LOWER) (BLUE)	
3	3-237-092-51	KNOB (HOLD) (for BLACK)		9	2-629-174-11	CASE (LOWER) (ORANGE)	
3	3-249-687-81	KNOB (HOLD) (for BLUE, ORANGE)		10	X-2055-437-1	BATTERY LID ASSY (M)	
4	2-588-291-21	ORNAMENT (CASE)					

7-2. PANEL (UPPER) SECTION

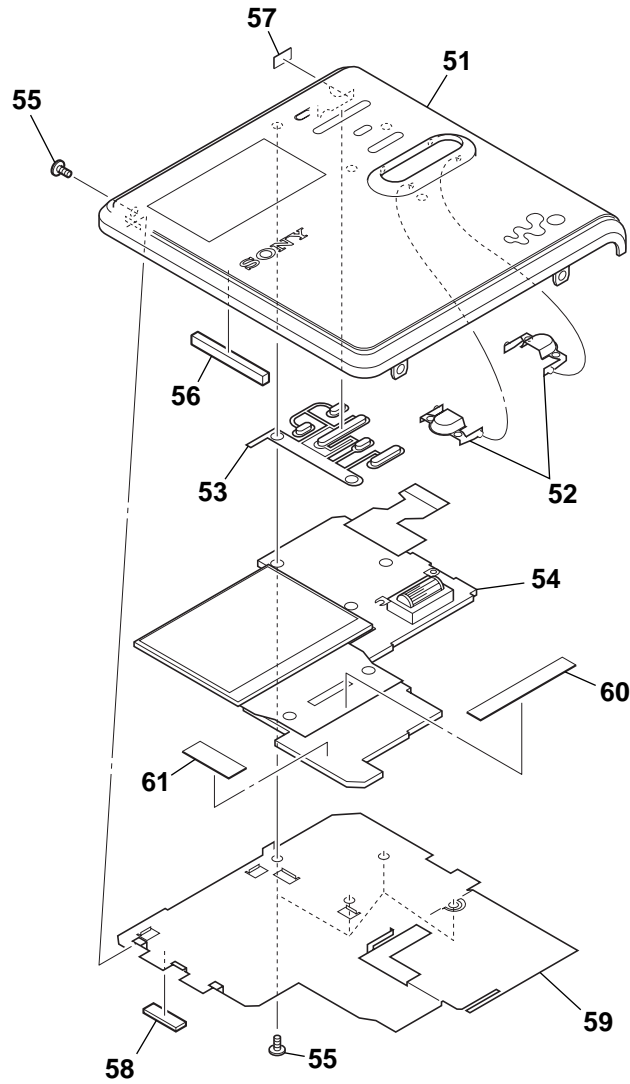

Ref. No.	Part No.	Description	Remark	Ref. No.	Part No.	Description	Remark
51	X-2055-745-1	PANEL (UPPER) (B) SV ASSY (BLACK)		54	A-1108-437-A	SWITCH UNIT ASSY (for SILVER, BLUE, ORANGE)	
51	X-2055-746-1	PANEL (UPPER) (S) SV ASSY (SILVER)		55	3-234-449-11	SCREW (M1.4)	
51	X-2055-747-1	PANEL (UPPER) (L) SV ASSY (BLUE)		56	2-590-008-01	SPACER (O/L)	
51	X-2055-748-1	PANEL (UPPER) (O) SV ASSY (ORANGE)		57	2-590-009-01	SPACER (L)	
52	2-588-282-01	BUTTON (FF/FR) (for BLACK)		58	2-596-596-01	SHEET, UPPER (PORON)	
52	2-588-282-11	BUTTON (FF/FR) (for SILVER, BLUE, ORANGE)		59	2-588-283-01	HOLDER LCD	
53	2-588-281-01	BUTTON (CONTROL) (for BLACK)		60	2-589-999-01	INSULATING SHEET (FPC)	
53	2-588-281-11	BUTTON (CONTROL) (for SILVER, BLUE, ORANGE)		61	2-590-003-01	INSULATING SHEET (UPPER PWB)	
54	A-1104-960-A	SWITCH UNIT ASSY (for BLACK)					

7-3. CHASSIS SECTION

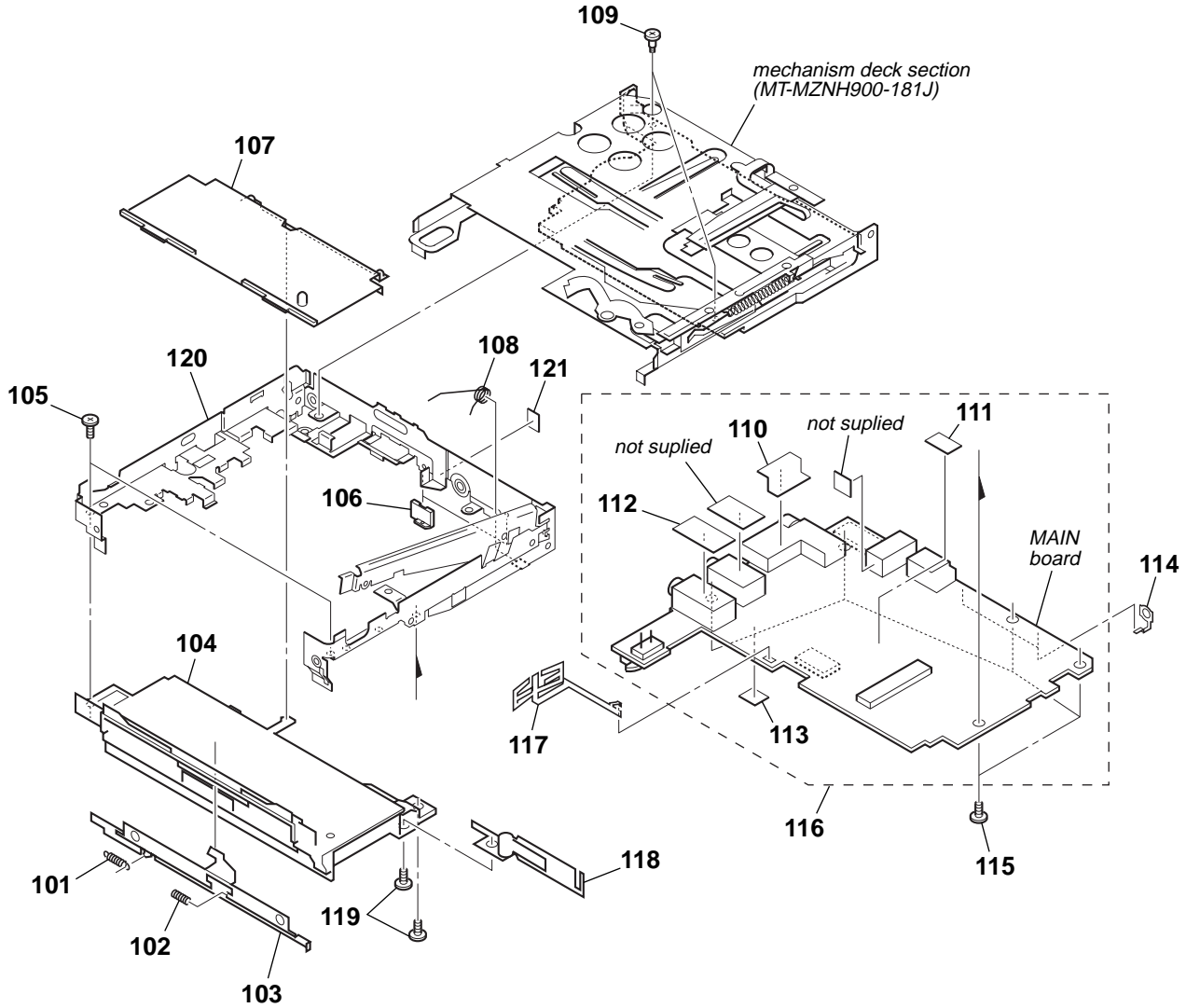

<u>Ref. No.</u>	<u>Part No.</u>	<u>Description</u>	<u>Remark</u>	<u>Ref. No.</u>	<u>Part No.</u>	<u>Description</u>	<u>Remark</u>
101	2-595-769-01	SPRING (LOCK), TENSION		112	2-024-013-01	SPACER (LINE IN)	
102	3-245-889-01	SPRING (LIMITTER), COMPRESSION		113	2-594-514-01	SPACER (IC)	
103	3-266-499-01	SLIDER, OPEN		114	2-588-273-01	TERMINAL (SUM3)	
104	3-266-506-01	CASE, BATTERY		115	3-238-876-04	SCREW (M1.4), TOOTHED LOCK	
105	3-254-003-01	SCREW		116	X-2025-842-1	MAIN BOARD, COMPLETE (for SERVICE)	
106	2-588-272-01	COVER (SUM3)		117	3-266-508-01	TERMINAL (-), BATTERY	
107	3-266-502-01	PIN, MD STANDARD		118	X-3382-584-2	TERMINAL (+) ASSY, BATTERY	
108	2-588-275-01	TORSION SPRING (R)		119	3-234-449-27	SCREW (M1.4)	
109	3-246-996-01	SCREW (MD), STEP		120	X-2050-643-1	CHASSIS ASSY, SET	
110	2-024-015-01	SPACER (HP)		121	2-630-349-01	SHEET (REC FPC), ADHESIVE	
111	2-594-513-01	SPECER (COIL)					

7-4. MECHANISM DECK SECTION (MT-MZNH900-181J)

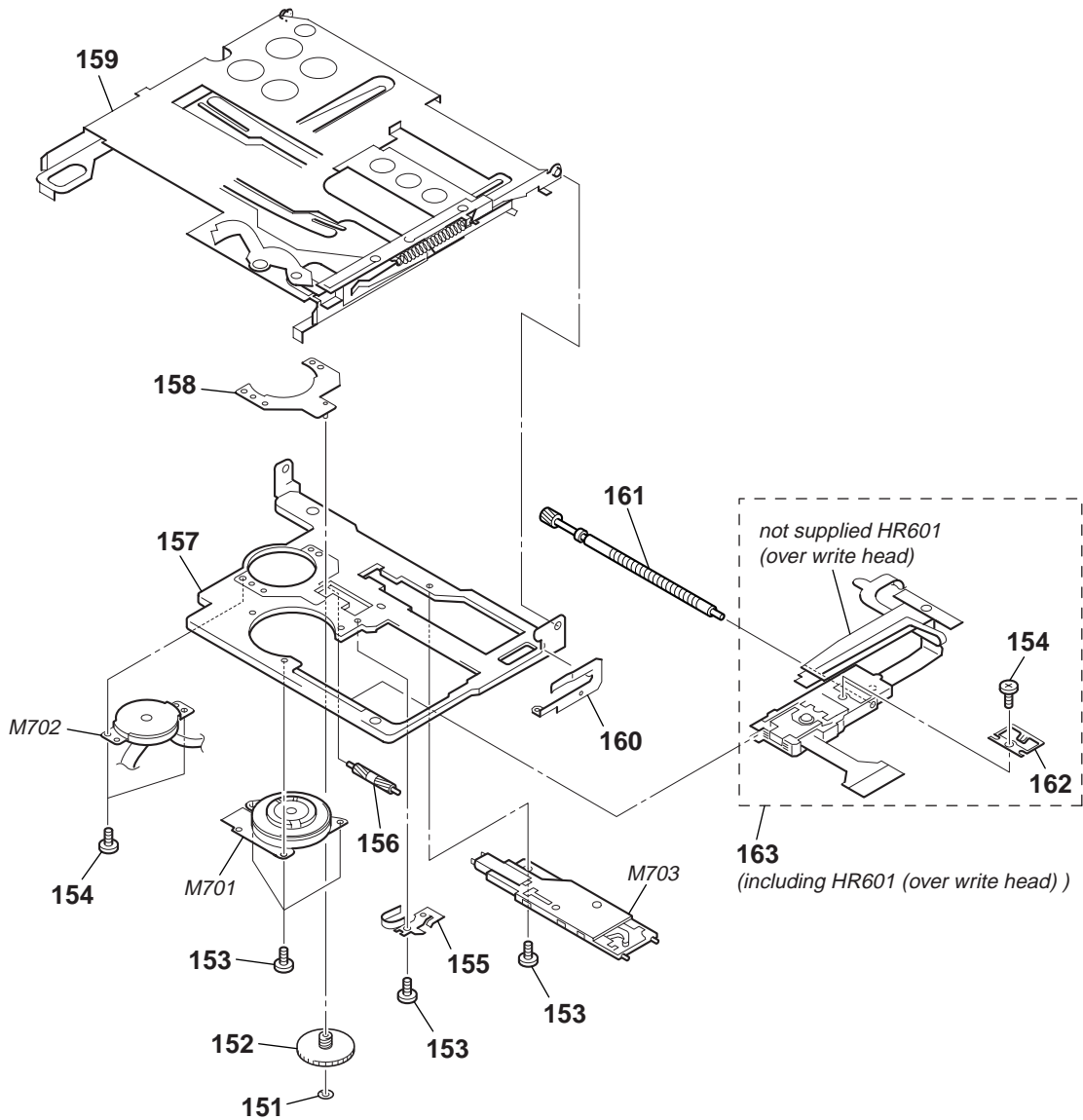

<p>The components identified by mark Δ or dotted line with mark Δ are critical for safety. Replace only with part number specified.</p>	<p>Les composants identifiés par une marque Δ sont critiques pour la sécurité. Ne les remplacer que par une pièce portant le numéro spécifié.</p>
---	---

Ref. No.	Part No.	Description	Remark	Ref. No.	Part No.	Description	Remark
151	3-338-645-31	WASHER (0.8-2.5)		161	X-2023-272-1	LEAD SCREW SERVICE ASSY	
152	3-263-454-01	GEAR (BSA)		162	3-244-879-01	SPRING, RACK	
153	3-248-370-01	SCREW, SELF TAP		Δ 163	X-2055-677-1	OP SERVICE ASSY (ABX-UJ) (including HR601(OVER WRITE HEAD))	
154	3-225-996-17	SCREW (M1.4) (EG), PRECISION PAN		M701	8-835-782-12	MOTOR, DC SSM18D/C-NP (SPINDLE)	
155	3-244-880-01	SPRING, THRUST RETAINER		M702	1-787-143-11	MOTOR, DC (SLED)	
156	3-263-455-01	GEAR (SB)		M703	1-477-519-21	MOTOR UNIT, DC (OVER WRITE HEAD UP/DOWN)	
157	3-259-972-24	CHASSIS (REC)					
158	X-3384-651-2	BASE ASSY, MOTOR					
159	X-3384-650-3	HOLDER ASSY					
160	3-263-453-01	PLATE, RATCHET					

SECTION 8 ELECTRICAL PARTS LIST

NOTE:

- Due to standardization, replacements in the parts list may be different from the parts specified in the diagrams or the components used on the set.
- -XX and -X mean standardized parts, so they may have some difference from the original one.
- RESISTORS
All resistors are in ohms.
METAL: Metal-film resistor.
METAL OXIDE: Metal oxide-film resistor.
F: nonflammable
- Abbreviation
AUS : Australian model HK : Hong Kong model
CND : Canadian model JE : Tourist model
EE : East European model KR : Korean model

- Items marked “*” are not stocked since they are seldom required for routine service. Some delay should be anticipated when ordering these items.
- SEMICONDUCTORS
In each case, u: μ , for example:
uA... : μ A... uPA... : μ PA...
uPB... : μ PB... uPC... : μ PC...
uPD... : μ PD...
• CAPACITORS
uF: μ F
• COILS
uH: μ H

The components identified by mark Δ or dotted line with mark Δ are critical for safety.
Replace only with part number specified.

Les composants identifiés par une marque Δ sont critiques pour la sécurité.
Ne les remplacer que par une pièce portant le numéro spécifié.

When indicating parts by reference number, please include the board.

Ref. No.	Part No.	Description	Remark	Ref. No.	Part No.	Description	Remark
	X-2055-842-1	MAIN BOARD, COMPLETE (for SERVICE) *****		C325	1-125-777-11	CERAMIC CHIP 0.1uF	10% 10V
	2-024-013-01	SPACER (LINE IN)		C327	1-125-837-11	CERAMIC CHIP 1uF	10% 6.3V
	2-024-015-01	SPACER (HP)		C328	1-125-837-11	CERAMIC CHIP 1uF	10% 6.3V
	2-594-513-01	SPECER (COIL)		C351	1-125-777-11	CERAMIC CHIP 0.1uF	10% 10V
	2-594-514-01	SPACER (IC)		C352	1-125-777-11	CERAMIC CHIP 0.1uF	10% 10V
	< CAPACITOR >			C354	1-125-837-11	CERAMIC CHIP 1uF	10% 6.3V
C101	1-164-874-11	CERAMIC CHIP 100PF	5% 50V	C355	1-128-964-11	TANTALUM CHIP 100uF	20% 6.3V
C102	1-125-837-11	CERAMIC CHIP 1uF	10% 6.3V	C356	1-128-964-11	TANTALUM CHIP 100uF	20% 6.3V
C104	1-164-939-11	CERAMIC CHIP 0.0022uF	10% 50V	C360	1-125-777-11	CERAMIC CHIP 0.1uF	10% 10V
C105	1-125-777-11	CERAMIC CHIP 0.1uF	10% 10V	C361	1-119-750-11	TANTALUM CHIP 22uF	20% 6.3V
C106	1-164-937-11	CERAMIC CHIP 0.001uF	10% 50V	C362	1-135-259-11	TANTALUM CHIP 10uF	20% 6.3V
C107	1-131-862-11	TANTALUM CHIP 47uF	20% 4V	C364	1-125-777-11	CERAMIC CHIP 0.1uF	10% 10V
C108	1-135-210-11	TANTALUM CHIP 4.7uF	20% 10V	C365	1-125-837-11	CERAMIC CHIP 1uF	10% 6.3V
C153	1-125-777-11	CERAMIC CHIP 0.1uF	10% 10V	C367	1-125-837-11	CERAMIC CHIP 1uF	10% 6.3V
C154	1-135-868-11	TANTALUM CHIP 220uF	20% 2.5V	C370	1-100-352-11	CERAMIC CHIP 1uF	20% 16V
C155	1-127-715-11	CERAMIC CHIP 0.22uF	10% 16V	C371	1-125-777-11	CERAMIC CHIP 0.1uF	10% 10V
C201	1-164-874-11	CERAMIC CHIP 100PF	5% 50V	C381	1-125-777-11	CERAMIC CHIP 0.1uF	10% 10V
C202	1-125-837-11	CERAMIC CHIP 1uF	10% 6.3V	C402	1-100-609-11	TANTALUM CHIP 220uF	5V
C204	1-164-939-11	CERAMIC CHIP 0.0022uF	10% 50V	C403	1-100-609-11	TANTALUM CHIP 220uF	5V
C205	1-125-777-11	CERAMIC CHIP 0.1uF	10% 10V	C406	1-125-777-11	CERAMIC CHIP 0.1uF	10% 10V
C206	1-164-937-11	CERAMIC CHIP 0.001uF	10% 50V	C407	1-125-777-11	CERAMIC CHIP 0.1uF	10% 10V
C207	1-131-862-11	TANTALUM CHIP 47uF	20% 4V	C408	1-125-777-11	CERAMIC CHIP 0.1uF	10% 10V
C208	1-135-210-11	TANTALUM CHIP 4.7uF	20% 10V	C409	1-164-943-11	CERAMIC CHIP 0.01uF	10% 16V
C253	1-125-777-11	CERAMIC CHIP 0.1uF	10% 10V	C411	1-119-751-11	TANTALUM CHIP 22uF	20% 16V
C254	1-135-868-11	TANTALUM CHIP 220uF	20% 2.5V	C412	1-125-777-11	CERAMIC CHIP 0.1uF	10% 10V
C255	1-127-715-11	CERAMIC CHIP 0.22uF	10% 16V	C415	1-125-777-11	CERAMIC CHIP 0.1uF	10% 10V
C303	1-125-777-11	CERAMIC CHIP 0.1uF	10% 10V	C417	1-125-777-11	CERAMIC CHIP 0.1uF	10% 10V
C310	1-135-259-11	TANTALUM CHIP 10uF	20% 6.3V	C419	1-125-777-11	CERAMIC CHIP 0.1uF	10% 10V
C311	1-125-777-11	CERAMIC CHIP 0.1uF	10% 10V	C420	1-125-777-11	CERAMIC CHIP 0.1uF	10% 10V
C312	1-100-539-11	TANTALUM CHIP 47uF	20% 6.3V	C421	1-125-777-11	CERAMIC CHIP 0.1uF	10% 10V
C313	1-100-539-11	TANTALUM CHIP 47uF	20% 6.3V	C424	1-128-964-11	TANTALUM CHIP 100uF	20% 6.3V
C314	1-125-777-11	CERAMIC CHIP 0.1uF	10% 10V	C426	1-119-751-11	TANTALUM CHIP 22uF	20% 16V
C315	1-165-851-11	TANTALUM CHIP 10uF	20% 6.3V	C452	1-107-826-11	CERAMIC CHIP 0.1uF	10% 16V
C316	1-119-750-11	TANTALUM CHIP 22uF	20% 6.3V	C453	1-165-176-11	CERAMIC CHIP 0.047uF	10% 16V
C318	1-135-149-21	TANTALUM CHIP 2.2uF	10% 10V	C479	1-125-777-11	CERAMIC CHIP 0.1uF	10% 10V
C319	1-125-777-11	CERAMIC CHIP 0.1uF	10% 10V	C480	1-125-837-11	CERAMIC CHIP 1uF	10% 6.3V
C320	1-135-149-21	TANTALUM CHIP 2.2uF	10% 10V	C481	1-125-837-11	CERAMIC CHIP 1uF	10% 6.3V
C321	1-100-539-11	TANTALUM CHIP 47uF	20% 6.3V	C491	1-104-915-11	TANTALUM CHIP 2.2uF	20% 20V
C322	1-125-777-11	CERAMIC CHIP 0.1uF	10% 10V	C492	1-164-850-11	CERAMIC CHIP 10PF	0.5PF 50V
C323	1-135-259-11	TANTALUM CHIP 10uF	20% 6.3V	C493	1-125-837-11	CERAMIC CHIP 1uF	10% 6.3V
C324	1-125-777-11	CERAMIC CHIP 0.1uF	10% 10V	C511	1-125-777-11	CERAMIC CHIP 0.1uF	10% 10V
				C513	1-164-943-11	CERAMIC CHIP 0.01uF	10% 16V
				C515	1-125-777-11	CERAMIC CHIP 0.1uF	10% 10V
				C516	1-125-777-11	CERAMIC CHIP 0.1uF	10% 10V

Ref. No.	Part No.	Description	Remark	Ref. No.	Part No.	Description	Remark
C517	1-125-777-11	CERAMIC CHIP	0.1uF 10% 10V	C633	1-164-943-11	CERAMIC CHIP	0.01uF 10% 16V
C518	1-135-210-11	TANTALUM CHIP	4.7uF 20% 10V	C634	1-125-837-11	CERAMIC CHIP	1uF 10% 6.3V
C519	1-125-777-11	CERAMIC CHIP	0.1uF 10% 10V	C635	1-100-539-11	TANTALUM CHIP	47uF 20% 6.3V
C520	1-125-777-11	CERAMIC CHIP	0.1uF 10% 10V	C636	1-125-777-11	CERAMIC CHIP	0.1uF 10% 10V
C521	1-164-850-11	CERAMIC CHIP	10PF 0.5PF 50V	C637	1-100-442-11	TANTALUM CHIP	10uF 20% 6.3V
C522	1-164-850-11	CERAMIC CHIP	10PF 0.5PF 50V	C638	1-164-943-11	CERAMIC CHIP	0.01uF 10% 16V
C523	1-125-777-11	CERAMIC CHIP	0.1uF 10% 10V	C641	1-164-943-11	CERAMIC CHIP	0.01uF 10% 16V
C524	1-162-970-11	CERAMIC CHIP	0.01uF 10% 25V	C642	1-119-923-11	CERAMIC CHIP	0.047uF 10% 10V
C525	1-164-941-11	CERAMIC CHIP	0.0047uF 10% 16V	C643	1-100-743-91	CERAMIC CHIP	2.2uF 20% 16V
C526	1-164-874-11	CERAMIC CHIP	100PF 5% 50V	C644	1-164-941-11	CERAMIC CHIP	0.0047uF 10% 16V
C527	1-125-777-11	CERAMIC CHIP	0.1uF 10% 10V	C645	1-164-943-11	CERAMIC CHIP	0.01uF 10% 16V
C528	1-125-777-11	CERAMIC CHIP	0.1uF 10% 10V	C646	1-119-923-11	CERAMIC CHIP	0.047uF 10% 10V
C529	1-125-777-11	CERAMIC CHIP	0.1uF 10% 10V	C648	1-119-923-11	CERAMIC CHIP	0.047uF 10% 10V
C530	1-125-837-11	CERAMIC CHIP	1uF 10% 6.3V	C650	1-100-442-11	TANTALUM CHIP	10uF 20% 6.3V
C531	1-164-943-11	CERAMIC CHIP	0.01uF 10% 16V	C652	1-135-259-11	TANTALUM CHIP	10uF 20% 6.3V
C533	1-164-943-11	CERAMIC CHIP	0.01uF 10% 16V	C653	1-135-259-11	TANTALUM CHIP	10uF 20% 6.3V
C536	1-107-819-11	CERAMIC CHIP	0.022uF 10% 16V	C658	1-100-539-11	TANTALUM CHIP	47uF 20% 6.3V
C537	1-125-837-11	CERAMIC CHIP	1uF 10% 6.3V	C662	1-165-851-11	TANTALUM CHIP	10uF 20% 6.3V
C538	1-164-941-11	CERAMIC CHIP	0.0047uF 10% 16V	C666	1-127-820-11	CERAMIC CHIP	4.7uF 10% 16V
C539	1-125-837-11	CERAMIC CHIP	1uF 10% 6.3V	C668	1-125-837-11	CERAMIC CHIP	1uF 10% 6.3V
C545	1-125-777-11	CERAMIC CHIP	0.1uF 10% 10V	C669	1-125-837-11	CERAMIC CHIP	1uF 10% 6.3V
C547	1-119-923-11	CERAMIC CHIP	0.047uF 10% 10V	C671	1-125-777-11	CERAMIC CHIP	0.1uF 10% 10V
C550	1-119-923-11	CERAMIC CHIP	0.047uF 10% 10V	C672	1-127-820-11	CERAMIC CHIP	4.7uF 10% 16V
C552	1-164-943-11	CERAMIC CHIP	0.01uF 10% 16V	C673	1-125-777-11	CERAMIC CHIP	0.1uF 10% 10V
C553	1-135-210-11	TANTALUM CHIP	4.7uF 20% 10V	C675	1-164-943-11	CERAMIC CHIP	0.01uF 10% 16V
C554	1-125-777-11	CERAMIC CHIP	0.1uF 10% 10V	C677	1-125-777-11	CERAMIC CHIP	0.1uF 10% 10V
C555	1-164-941-11	CERAMIC CHIP	0.0047uF 10% 16V	C701	1-119-923-11	CERAMIC CHIP	0.047uF 10% 10V
C556	1-135-210-11	TANTALUM CHIP	4.7uF 20% 10V	C702	1-119-923-11	CERAMIC CHIP	0.047uF 10% 10V
C557	1-125-777-11	CERAMIC CHIP	0.1uF 10% 10V	C703	1-119-923-11	CERAMIC CHIP	0.047uF 10% 10V
C558	1-164-937-11	CERAMIC CHIP	0.001uF 10% 50V	C705	1-164-943-11	CERAMIC CHIP	0.01uF 10% 16V
C559	1-164-941-11	CERAMIC CHIP	0.0047uF 10% 16V	C706	1-107-819-11	CERAMIC CHIP	0.022uF 10% 16V
C560	1-125-777-11	CERAMIC CHIP	0.1uF 10% 10V	C707	1-164-943-11	CERAMIC CHIP	0.01uF 10% 16V
C564	1-135-210-11	TANTALUM CHIP	4.7uF 20% 10V	C708	1-107-819-11	CERAMIC CHIP	0.022uF 10% 16V
C565	1-125-777-11	CERAMIC CHIP	0.1uF 10% 10V	C709	1-164-943-11	CERAMIC CHIP	0.01uF 10% 16V
C566	1-125-777-11	CERAMIC CHIP	0.1uF 10% 10V	C710	1-107-819-11	CERAMIC CHIP	0.022uF 10% 16V
C567	1-135-210-11	TANTALUM CHIP	4.7uF 20% 10V	C712	1-125-777-11	CERAMIC CHIP	0.1uF 10% 10V
C570	1-112-014-11	TANTALUM CHIP	4.7uF 20% 6.3V	C713	1-125-777-11	CERAMIC CHIP	0.1uF 10% 10V
C573	1-164-933-11	CERAMIC CHIP	220PF 10% 50V	C714	1-125-777-11	CERAMIC CHIP	0.1uF 10% 10V
C601	1-125-837-11	CERAMIC CHIP	1uF 10% 6.3V	C715	1-125-777-11	CERAMIC CHIP	0.1uF 10% 10V
C602	1-125-777-11	CERAMIC CHIP	0.1uF 10% 10V	C716	1-125-777-11	CERAMIC CHIP	0.1uF 10% 10V
C604	1-125-777-11	CERAMIC CHIP	0.1uF 10% 10V	C717	1-125-777-11	CERAMIC CHIP	0.1uF 10% 10V
C607	1-125-837-11	CERAMIC CHIP	1uF 10% 6.3V	C801	1-164-846-11	CERAMIC CHIP	6PF 0.5PF 50V
C609	1-125-837-11	CERAMIC CHIP	1uF 10% 6.3V	C802	1-164-846-11	CERAMIC CHIP	6PF 0.5PF 50V
C611	1-164-943-11	CERAMIC CHIP	0.01uF 10% 16V	C803	1-164-943-11	CERAMIC CHIP	0.01uF 10% 16V
C612	1-119-750-11	TANTALUM CHIP	22uF 20% 6.3V	C804	1-164-943-11	CERAMIC CHIP	0.01uF 10% 16V
C613	1-119-750-11	TANTALUM CHIP	22uF 20% 6.3V	C805	1-125-891-11	CERAMIC CHIP	0.47uF 10% 10V
C614	1-119-750-11	TANTALUM CHIP	22uF 20% 6.3V	C808	1-125-837-11	CERAMIC CHIP	1uF 10% 6.3V
C616	1-165-897-11	TANTALUM CHIP	22uF 20% 10V	C809	1-125-777-11	CERAMIC CHIP	0.1uF 10% 10V
C619	1-125-837-11	CERAMIC CHIP	1uF 10% 6.3V	C810	1-125-777-11	CERAMIC CHIP	0.1uF 10% 10V
C620	1-119-923-11	CERAMIC CHIP	0.047uF 10% 10V	C811	1-125-777-11	CERAMIC CHIP	0.1uF 10% 10V
C621	1-117-919-11	TANTALUM CHIP	10uF 20% 6.3V	C812	1-125-837-11	CERAMIC CHIP	1uF 10% 6.3V
C622	1-100-539-11	TANTALUM CHIP	47uF 20% 6.3V	C813	1-119-923-11	CERAMIC CHIP	0.047uF 10% 10V
C623	1-164-933-11	CERAMIC CHIP	220PF 10% 50V	C814	1-125-777-11	CERAMIC CHIP	0.1uF 10% 10V
C625	1-125-777-11	CERAMIC CHIP	0.1uF 10% 10V	C816	1-100-539-11	TANTALUM CHIP	47uF 20% 6.3V
C627	1-100-539-11	TANTALUM CHIP	47uF 20% 6.3V	C817	1-125-777-11	CERAMIC CHIP	0.1uF 10% 10V
C628	1-125-837-11	CERAMIC CHIP	1uF 10% 6.3V	C818	1-165-851-11	TANTALUM CHIP	10uF 20% 6.3V
C630	1-125-777-11	CERAMIC CHIP	0.1uF 10% 10V	C819	1-100-539-11	TANTALUM CHIP	47uF 20% 6.3V
				C820	1-125-777-11	CERAMIC CHIP	0.1uF 10% 10V

MAIN

Ref. No.	Part No.	Description	Remark	Ref. No.	Part No.	Description	Remark
C821	1-164-874-11	CERAMIC CHIP 100PF 5%	50V	C3301	1-164-931-11	CERAMIC CHIP 100PF 10%	50V
C822	1-125-777-11	CERAMIC CHIP 0.1uF 10%	10V	C3302	1-164-939-11	CERAMIC CHIP 0.0022uF 10%	50V
C823	1-125-777-11	CERAMIC CHIP 0.1uF 10%	10V	C3304	1-164-943-11	CERAMIC CHIP 0.01uF 10%	16V
C827	1-125-777-11	CERAMIC CHIP 0.1uF 10%	10V	C3305	1-164-943-11	CERAMIC CHIP 0.01uF 10%	16V
C828	1-164-937-11	CERAMIC CHIP 0.001uF 10%	50V	C3306	1-164-941-11	CERAMIC CHIP 0.0047uF 10%	16V
C830	1-164-937-11	CERAMIC CHIP 0.001uF 10%	50V	C3308	1-164-937-11	CERAMIC CHIP 0.001uF 10%	50V
C835	1-125-777-11	CERAMIC CHIP 0.1uF 10%	10V	C3309	1-164-937-11	CERAMIC CHIP 0.001uF 10%	50V
C836	1-165-851-11	TANTALUM CHIP 10uF 20%	6.3V	C3331	1-164-931-11	CERAMIC CHIP 100PF 10%	50V
C838	1-165-851-11	TANTALUM CHIP 10uF 20%	6.3V	C3332	1-164-931-11	CERAMIC CHIP 100PF 10%	50V
C839	1-125-777-11	CERAMIC CHIP 0.1uF 10%	10V	C3372	1-164-937-11	CERAMIC CHIP 0.001uF 10%	50V
C843	1-125-777-11	CERAMIC CHIP 0.1uF 10%	10V	C3374	1-164-937-11	CERAMIC CHIP 0.001uF 10%	50V
C845	1-100-539-11	TANTALUM CHIP 47uF 20%	6.3V	C4416	1-164-937-11	CERAMIC CHIP 0.001uF 10%	50V
C846	1-125-777-11	CERAMIC CHIP 0.1uF 10%	10V	C4418	1-164-937-11	CERAMIC CHIP 0.001uF 10%	50V
C847	1-125-777-11	CERAMIC CHIP 0.1uF 10%	10V	C4425	1-164-937-11	CERAMIC CHIP 0.001uF 10%	50V
C850	1-125-777-11	CERAMIC CHIP 0.1uF 10%	10V	C4427	1-164-933-11	CERAMIC CHIP 220PF 10%	50V
C853	1-125-777-11	CERAMIC CHIP 0.1uF 10%	10V	C4428	1-164-937-11	CERAMIC CHIP 0.001uF 10%	50V
C856	1-125-777-11	CERAMIC CHIP 0.1uF 10%	10V	C4429	1-164-937-11	CERAMIC CHIP 0.001uF 10%	50V
C857	1-164-858-11	CERAMIC CHIP 22PF 5%	50V	C4438	1-164-937-11	CERAMIC CHIP 0.001uF 10%	50V
C861	1-125-777-11	CERAMIC CHIP 0.1uF 10%	10V	C4455	1-164-937-11	CERAMIC CHIP 0.001uF 10%	50V
C883	1-135-259-11	TANTALUM CHIP 10uF 20%	6.3V	C4456	1-164-937-11	CERAMIC CHIP 0.001uF 10%	50V
C884	1-135-259-11	TANTALUM CHIP 10uF 20%	6.3V	C4458	1-164-937-11	CERAMIC CHIP 0.001uF 10%	50V
C885	1-125-837-11	CERAMIC CHIP 1uF 10%	6.3V	C4459	1-164-937-11	CERAMIC CHIP 0.001uF 10%	50V
C886	1-164-943-11	CERAMIC CHIP 0.01uF 10%	16V	C4462	1-164-874-11	CERAMIC CHIP 100PF 5%	50V
C887	1-125-837-11	CERAMIC CHIP 1uF 10%	6.3V	C4463	1-164-874-11	CERAMIC CHIP 100PF 5%	50V
C888	1-164-943-11	CERAMIC CHIP 0.01uF 10%	16V	C4464	1-125-777-11	CERAMIC CHIP 0.1uF 10%	10V
C891	1-125-777-11	CERAMIC CHIP 0.1uF 10%	10V	C4465	1-164-937-11	CERAMIC CHIP 0.001uF 10%	50V
C892	1-125-777-11	CERAMIC CHIP 0.1uF 10%	10V	C4466	1-164-937-11	CERAMIC CHIP 0.001uF 10%	50V
C895	1-125-777-11	CERAMIC CHIP 0.1uF 10%	10V	C4467	1-164-937-11	CERAMIC CHIP 0.001uF 10%	50V
C901	1-125-777-11	CERAMIC CHIP 0.1uF 10%	10V	C4485	1-125-777-11	CERAMIC CHIP 0.1uF 10%	10V
C902	1-125-777-11	CERAMIC CHIP 0.1uF 10%	10V	C6649	1-125-777-11	CERAMIC CHIP 0.1uF 10%	10V
C903	1-164-943-11	CERAMIC CHIP 0.01uF 10%	16V	C6674	1-112-010-11	CAP-CHIP 33PF 5%	100V
C906	1-100-352-11	CERAMIC CHIP 1uF 20%	16V	C6676	1-164-937-11	CERAMIC CHIP 0.001uF 10%	50V
C908	1-164-943-11	CERAMIC CHIP 0.01uF 10%	16V	C6679	1-164-866-11	CERAMIC CHIP 47PF 5%	50V
C909	1-119-751-11	TANTALUM CHIP 22uF 20%	16V	C6680	1-164-937-11	CERAMIC CHIP 0.001uF 10%	50V
C915	1-100-442-11	TANTALUM CHIP 10uF 20%	6.3V	C8858	1-164-937-11	CERAMIC CHIP 0.001uF 10%	50V
C916	1-100-442-11	TANTALUM CHIP 10uF 20%	6.3V	C8859	1-164-937-11	CERAMIC CHIP 0.001uF 10%	50V
C918	1-165-176-11	CERAMIC CHIP 0.047uF 10%	16V	C8864	1-164-935-11	CERAMIC CHIP 470PF 10%	50V
C919	1-164-227-11	CERAMIC CHIP 0.022uF 10%	25V	C8893	1-164-937-11	CERAMIC CHIP 0.001uF 10%	50V
C920	1-125-777-11	CERAMIC CHIP 0.1uF 10%	10V	C9001	1-162-970-11	CERAMIC CHIP 0.01uF 10%	25V
C922	1-128-964-11	TANTALUM CHIP 100uF 20%	6.3V	C9957	1-164-933-11	CERAMIC CHIP 220PF 10%	50V
C923	1-100-539-11	TANTALUM CHIP 47uF 20%	6.3V	< CONNECTOR >			
C924	1-100-539-11	TANTALUM CHIP 47uF 20%	6.3V	CN451	1-818-190-21	CONNECTOR, SQUARE TYPE (USB) 7P	
C931	1-165-884-11	CERAMIC CHIP 2.2uF 10%	6.3V	CN471	1-819-098-21	CONNECTOR, FFC/FPC (ZIF) 18P	
C932	1-164-943-11	CERAMIC CHIP 0.01uF 10%	16V	CN501	1-818-547-21	CONNECTOR, FFC/FPC (ZIF) 26P	
C933	1-165-884-11	CERAMIC CHIP 2.2uF 10%	6.3V	CN701	1-818-540-21	CONNECTOR, FFC/FPC (ZIF) 10P	
C935	1-165-884-11	CERAMIC CHIP 2.2uF 10%	6.3V	< DIODE/VARISTOR >			
C936	1-165-884-11	CERAMIC CHIP 2.2uF 10%	6.3V	D401	6-501-199-01	DIODE NSR0320MW2T1G	
C937	1-165-884-11	CERAMIC CHIP 2.2uF 10%	6.3V	D438	6-500-483-01	DIODE MA22D2800LS0	
C939	1-119-750-11	TANTALUM CHIP 22uF 20%	6.3V	D440	6-500-483-01	DIODE MA22D2800LS0	
C940	1-119-750-11	TANTALUM CHIP 22uF 20%	6.3V	D443	6-500-912-01	DIODE MA2SD3100LS0	
C945	1-164-939-11	CERAMIC CHIP 0.0022uF 10%	50V	D444	6-500-912-01	DIODE MA2SD3100LS0	
C946	1-164-941-11	CERAMIC CHIP 0.0047uF 10%	16V	D450	6-501-199-01	DIODE NSR0320MW2T1G	
C948	1-119-750-11	TANTALUM CHIP 22uF 20%	6.3V	D457	6-500-483-01	DIODE MA22D2800LS0	
C954	1-164-937-11	CERAMIC CHIP 0.001uF 10%	50V	D458	8-719-422-49	DIODE MA8056-L	
C958	1-125-837-11	CERAMIC CHIP 1uF 10%	6.3V	D471	8-719-072-27	DIODE MA2Z748001S0	
C959	1-125-777-11	CERAMIC CHIP 0.1uF 10%	10V	D491	6-501-200-01	DIODE HRC0201ATRF-E	
C961	1-125-777-11	CERAMIC CHIP 0.1uF 10%	10V				

Ref. No.	Part No.	Description	Remark	Ref. No.	Part No.	Description	Remark
D601	6-500-813-01	DIODE MA2SD32008S0				< IC >	
D602	8-719-072-27	DIODE MA2Z748001S0		IC301	(Not supplied)	IC AK5356VN-L	
D604	6-500-483-01	DIODE MA22D2800LS0		IC302	6-706-528-01	IC XC6219B212MR	
D605	6-501-201-01	DIODE BAT54XV2T1		IC351	6-706-746-01	IC NJU8716AV (TE2)	
D606	6-500-909-01	DIODE MA22D1700LS0		@ IC401	6-707-717-01	IC MM1690NCBE	
				IC471	6-705-715-01	IC XC6219B242MR	
D607	6-500-909-01	DIODE MA22D1700LS0					
D608	6-501-201-01	DIODE BAT54XV2T1		IC491	6-707-762-01	IC XC9103D092MR	
D613	6-500-813-01	DIODE MA2SD32008S0		@ IC501	6-705-012-11	IC SN761059AZQLR	
D614	6-500-813-01	DIODE MA2SD32008S0		@ IC601	6-705-000-01	IC SC901585VAR2	
D801	6-501-200-01	DIODE HRC0201ATRF-E		IC602	6-703-317-01	IC R1160N121B-TR-FA	
				IC604	6-706-079-01	IC R1180Q121C-TR-FA	
D803	6-500-813-01	DIODE MA2SD32008S0					
D881	6-500-813-01	DIODE MA2SD32008S0		IC605	6-706-214-01	IC TC7SL32FU (TE85R)	
D882	6-500-813-01	DIODE MA2SD32008S0		IC606	6-702-590-01	IC XC61CN1702NR	
D883	6-500-813-01	DIODE MA2SD32008S0		IC607	8-759-690-72	IC XC61CN0902NR	
D884	8-719-072-27	DIODE MA2Z748001S0		IC701	6-705-001-01	IC SC901583EPR2	
				@ IC801	8-753-239-65	IC CXD2681-225GG	
D885	8-719-072-27	DIODE MA2Z748001S0					
D904	6-501-200-01	DIODE HRC0201ATRF-E		IC804	6-704-732-01	IC PST3325UL	
D905	6-501-200-01	DIODE HRC0201ATRF-E		IC881	6-708-012-01	IC MM3005BNLE	
D906	6-501-199-01	DIODE NSR0320MW2T1G		IC882	6-706-094-01	IC R1180Q221B-TR-FA	
D3305	8-719-083-91	DIODE EDZ TE61 6.8B		IC891	6-702-168-01	IC AK6512CM-E2	
				IC901	6-704-997-01	IC SC901584EPR2	
D3352	8-719-081-71	DIODE DF8A6.8FK (TE85R)					
D4435	8-719-978-33	DIODE DTZ-TT11-6.8B		IC903	6-704-245-01	IC XC61CC1702NR	
D4436	8-719-083-91	DIODE EDZ TE61 6.8B					
D4441	8-719-978-33	DIODE DTZ-TT11-6.8B				< JACK >	
D4442	1-805-697-21	VARIATOR (SMD)					
D4443	8-719-083-91	DIODE EDZ TE61 6.8B		J301	1-815-950-12	JACK (LINE IN (OPT))	
D4456	8-719-083-91	DIODE EDZ TE61 6.8B		J302	1-794-084-12	JACK (MIC (PLUG IN POWER))	
D6615	6-500-909-01	DIODE MA22D1700LS0		J351	1-816-153-21	JACK (⊘)	
D6616	6-500-909-01	DIODE MA22D1700LS0		J402	1-785-383-11	JACK, DC (POLARITY UNIFIED TYPE)(DC IN 3V)	
		< FUSE >				< COIL/RESISTOR >	
△ F351	1-576-439-41	FUSE (0.25A/125V)		L152	1-400-582-21	INDUCTOR	47uH
				L252	1-400-582-21	INDUCTOR	47uH
		< JUMPER RESISTOR/FERRITE BEAD >		L303	1-400-397-11	INDUCTOR	10uH
				L491	1-469-952-21	COIL, CHOKE	22uH
				L502	1-400-397-11	INDUCTOR	10uH
FB802	1-218-990-11	SHORT CHIP	0				
FB807	1-218-990-11	SHORT CHIP	0	L503	1-400-397-11	INDUCTOR	10uH
FB808	1-218-990-11	SHORT CHIP	0	L504	1-400-397-11	INDUCTOR	10uH
FB1101	1-500-283-11	INDUCTOR, FERRITE BEAD		L505	1-400-397-11	INDUCTOR	10uH
FB1102	1-400-591-22	BEAD, FERRITE (CHIP) (1608)		L506	1-400-397-11	INDUCTOR	10uH
				L507	1-400-397-11	INDUCTOR	10uH
FB1151	1-400-180-21	INDUCTOR, EMI FERRITE (1608)					
FB2201	1-500-283-11	INDUCTOR, FERRITE BEAD		L601	1-414-398-11	INDUCTOR	10uH
FB2202	1-400-591-22	BEAD, FERRITE (CHIP) (1608)		L603	1-414-398-11	INDUCTOR	10uH
FB2251	1-400-180-21	INDUCTOR, EMI FERRITE (1608)		L605	1-456-697-21	COIL, CHOKE	22uH
FB3301	1-500-283-11	INDUCTOR, FERRITE BEAD		L606	1-400-626-11	COIL, CHOKE	10uH
				L607	1-456-697-21	COIL, CHOKE	22uH
FB3302	1-400-591-22	BEAD, FERRITE (CHIP) (1608)					
FB3351	1-400-180-21	INDUCTOR, EMI FERRITE (1608)		L608	1-400-402-21	INDUCTOR	4.7uH
FB3353	1-469-179-21	INDUCTOR, FERRITE BEAD		L801	1-400-397-11	INDUCTOR	10uH
FB3355	1-469-179-21	INDUCTOR, FERRITE BEAD		L802	1-400-343-21	INDUCTOR	22uH
FB3357	1-469-179-21	INDUCTOR, FERRITE BEAD		L803	1-216-001-00	RES-CHIP	10 5% 1/10W
				L804	1-216-001-00	RES-CHIP	10 5% 1/10W
FB4451	1-469-869-21	INDUCTOR (EMI FERRITE) (2012)					
FB4452	1-469-869-21	INDUCTOR (EMI FERRITE) (2012)		L806	1-400-342-21	INDUCTOR	10uH
FB5501	1-218-990-11	SHORT CHIP	0	L881	1-414-404-41	COIL, CHOKE	100uH
FB5503	1-216-864-11	SHORT CHIP	0	L901	1-456-710-21	COIL, CHOKE	100uH
FB8803	1-216-864-11	SHORT CHIP	0	L903	1-400-397-11	INDUCTOR	10uH
				L904	1-400-397-11	INDUCTOR	10uH
FB8810	1-218-990-11	SHORT CHIP	0				
				L906	1-456-677-21	COIL, CHOKE	47uH
				L907	1-456-677-21	COIL, CHOKE	47uH

The components identified by mark △ or dotted line with mark △ are critical for safety. Replace only with part number specified.

Les composants identifiés par une marque △ sont critiques pour la sécurité. Ne les remplacer que par une pièce portant le numéro spécifié.

@ Replacement of IC401, IC501, IC601 and IC801 used in this set requires a special tool.

MZ-RH10

MAIN

Ref. No.	Part No.	Description	Remark	Ref. No.	Part No.	Description	Remark
		< FILTER/COIL >		R107	1-208-715-11	METAL CHIP	22K 0.5% 1/16W
LF401	1-411-957-11	FILTER, COMMON MODE		R151	1-218-961-11	RES-CHIP	4.7K 5% 1/16W
LF4451	1-456-111-11	COIL, COMMON MODE CHOKE					
		< TRANSISTOR >		R155	1-218-929-11	RES-CHIP	10 5% 1/16W
Q151	6-550-379-01	FET	2SK354700LS0	R156	1-218-937-11	RES-CHIP	47 5% 1/16W
Q251	6-550-379-01	FET	2SK354700LS0	R201	1-208-927-11	METAL CHIP	47K 0.5% 1/16W
Q301	8-729-051-23	TRANSISTOR	2SA2018TL	R203	1-208-715-11	METAL CHIP	22K 0.5% 1/16W
Q351	6-550-859-01	FET	NTHD4508NT1G	R206	1-208-911-11	METAL CHIP	10K 0.5% 1/16W
Q352	6-551-127-01	TRANSISTOR	RT1P441U-TP-1				
Q353	6-551-154-01	TRANSISTOR	RT2C00M-TP	R207	1-208-715-11	METAL CHIP	22K 0.5% 1/16W
Q401	6-551-329-01	TRANSISTOR	TPCP8601 (TE85L, F)	R251	1-218-961-11	RES-CHIP	4.7K 5% 1/16W
Q402	6-551-334-01	FET	RTL035N03TR	R255	1-218-929-11	RES-CHIP	10 5% 1/16W
Q403	6-551-334-01	FET	RTL035N03TR	R256	1-218-937-11	RES-CHIP	47 5% 1/16W
Q406	6-551-321-01	TRANSISTOR	RT3WLMM-TP-1F	R301	1-218-953-11	RES-CHIP	1K 5% 1/16W
Q407	6-551-327-01	TRANSISTOR	RT1N144U-TP-1	R302	1-400-807-21	BEAD, FERRITE (1005)	
Q432	6-551-328-01	TRANSISTOR	TPCP8501 (TE85L, F)	R303	1-400-807-21	BEAD, FERRITE (1005)	
Q433	6-551-325-01	TRANSISTOR	2SC5383-TP-1F	R304	1-218-977-11	RES-CHIP	100K 5% 1/16W
Q441	8-729-030-46	TRANSISTOR	XP4314-TX	R305	1-218-941-11	RES-CHIP	100 5% 1/16W
Q442	6-551-334-01	FET	RTL035N03TR	R306	1-218-965-11	RES-CHIP	10K 5% 1/16W
Q451	6-550-354-01	FET	RTQ035P02TR	R307	1-218-941-11	RES-CHIP	100 5% 1/16W
Q452	6-551-321-01	TRANSISTOR	RT3WLMM-TP-1F	R309	1-218-953-11	RES-CHIP	1K 5% 1/16W
Q471	6-551-154-01	TRANSISTOR	RT2C00M-TP	R310	1-218-953-11	RES-CHIP	1K 5% 1/16W
Q491	6-551-273-01	FET	RTR025N03TL	R312	1-218-929-11	RES-CHIP	10 5% 1/16W
Q492	6-551-334-01	FET	RTL035N03TR	R314	1-218-990-11	SHORT CHIP	0
Q493	8-729-030-46	TRANSISTOR	XP4314-TX	R351	1-218-989-11	RES-CHIP	1M 5% 1/16W
Q502	8-729-051-23	TRANSISTOR	2SA2018TL	R352	1-218-973-11	RES-CHIP	47K 5% 1/16W
Q503	6-551-325-01	TRANSISTOR	2SC5383-TP-1F	R353	1-208-715-11	METAL CHIP	22K 0.5% 1/16W
Q504	8-729-037-89	TRANSISTOR	2SC4627J-C (TX).SO	R354	1-218-990-11	SHORT CHIP	0
Q601	6-550-357-01	FET	CPH5614-TL-E	R355	1-218-989-11	RES-CHIP	1M 5% 1/16W
Q602	6-550-740-01	FET	MCH6617-TL-E	R356	1-218-957-11	RES-CHIP	2.2K 5% 1/16W
Q603	6-550-859-01	FET	NTHD4508NT1G	R357	1-218-973-11	RES-CHIP	47K 5% 1/16W
Q608	8-729-030-46	TRANSISTOR	XP4314-TX	R358	1-218-990-11	SHORT CHIP	0
Q609	6-550-859-01	FET	NTHD4508NT1G	R359	1-218-985-11	RES-CHIP	470K 5% 1/16W
Q611	6-551-334-01	FET	RTL035N03TR	R360	1-218-977-11	RES-CHIP	100K 5% 1/16W
Q612	6-551-273-01	FET	RTR025N03TL	R361	1-218-933-11	RES-CHIP	22 5% 1/16W
Q616	6-551-334-01	FET	RTL035N03TR	R362	1-218-985-11	RES-CHIP	470K 5% 1/16W
Q617	6-551-321-01	TRANSISTOR	RT3WLMM-TP-1F	R364	1-216-864-11	SHORT CHIP	0
Q618	6-551-321-01	TRANSISTOR	RT3WLMM-TP-1F	R365	1-218-990-11	SHORT CHIP	0
Q801	8-729-047-68	FET	SSM3K03FE (TPL3)	R366	1-218-990-11	SHORT CHIP	0
Q802	8-729-051-50	FET	XP152A12COMR	R401	1-218-990-11	SHORT CHIP	0
Q803	6-551-325-01	TRANSISTOR	2SC5383-TP-1F	R413	1-218-977-11	RES-CHIP	100K 5% 1/16W
Q881	6-551-321-01	TRANSISTOR	RT3WLMM-TP-1F	R414	1-218-965-11	RES-CHIP	10K 5% 1/16W
Q883	6-551-327-01	TRANSISTOR	RT1N144U-TP-1	R415	1-218-961-11	RES-CHIP	4.7K 5% 1/16W
Q884	8-729-048-77	TRANSISTOR	XP4313- (TX).SO	R417	1-218-989-11	RES-CHIP	1M 5% 1/16W
Q885	6-551-334-01	FET	RTL035N03TR	R418	1-218-977-11	RES-CHIP	100K 5% 1/16W
Q886	8-729-030-46	TRANSISTOR	XP4314-TX	R419	1-218-965-11	RES-CHIP	10K 5% 1/16W
Q901	6-550-818-01	FET	US6K1TR	R420	1-218-961-11	RES-CHIP	4.7K 5% 1/16W
Q904	6-551-334-01	FET	RTL035N03TR	R421	1-218-977-11	RES-CHIP	100K 5% 1/16W
Q905	8-729-030-46	TRANSISTOR	XP4314-TX	R422	1-218-989-11	RES-CHIP	1M 5% 1/16W
Q906	6-551-321-01	TRANSISTOR	RT3WLMM-TP-1F	R423	1-218-981-11	RES-CHIP	220K 5% 1/16W
		< RESISTOR/FERRITE BEAD >		R424	1-218-985-11	RES-CHIP	470K 5% 1/16W
R101	1-208-927-11	METAL CHIP	47K 0.5% 1/16W	R425	1-218-957-11	RES-CHIP	2.2K 5% 1/16W
R103	1-208-715-11	METAL CHIP	22K 0.5% 1/16W	R426	1-218-990-11	SHORT CHIP	0
R106	1-208-911-11	METAL CHIP	10K 0.5% 1/16W	R432	1-245-456-21	METAL CHIP	1 1% 1/5W
				R433	1-245-455-21	METAL CHIP	0.47 1% 1/5W
				R434	1-218-989-11	RES-CHIP	1M 5% 1/16W
				R436	1-218-981-11	RES-CHIP	220K 5% 1/16W
				R437	1-218-981-11	RES-CHIP	220K 5% 1/16W
				R438	1-218-977-11	RES-CHIP	100K 5% 1/16W

Ref. No.	Part No.	Description	Quantity	Unit	Remark	Ref. No.	Part No.	Description	Quantity	Unit	Remark
R441	1-218-990-11	SHORT CHIP	0			R647	1-218-989-11	RES-CHIP	1M	5%	1/16W
R442	1-218-977-11	RES-CHIP	100K	5%	1/16W	R648	1-245-456-21	METAL CHIP	1	1%	1/5W
R443	1-218-977-11	RES-CHIP	100K	5%	1/16W						
R455	1-218-989-11	RES-CHIP	1M	5%	1/16W	R649	1-245-456-21	METAL CHIP	1	1%	1/5W
R456	1-218-985-11	RES-CHIP	470K	5%	1/16W	R651	1-245-456-21	METAL CHIP	1	1%	1/5W
						R653	1-218-969-11	RES-CHIP	22K	5%	1/16W
R462	1-218-981-11	RES-CHIP	220K	5%	1/16W	R654	1-218-989-11	RES-CHIP	1M	5%	1/16W
R463	1-218-945-11	RES-CHIP	220	5%	1/16W	R659	1-218-977-11	RES-CHIP	100K	5%	1/16W
R464	1-208-935-11	METAL CHIP	100K	0.5%	1/16W						
R466	1-220-804-11	RES-CHIP	2.2M	5%	1/16W	R660	1-218-985-11	RES-CHIP	470K	5%	1/16W
R467	1-218-965-11	RES-CHIP	10K	5%	1/16W	R661	1-218-985-11	RES-CHIP	470K	5%	1/16W
						R662	1-218-985-11	RES-CHIP	470K	5%	1/16W
R472	1-218-937-11	RES-CHIP	47	5%	1/16W	R663	1-218-981-11	RES-CHIP	220K	5%	1/16W
R473	1-218-990-11	SHORT CHIP	0			R664	1-216-789-11	METAL CHIP	2.2	5%	1/10W
R476	1-208-699-11	METAL CHIP	4.7K	0.5%	1/16W						
R477	1-208-699-11	METAL CHIP	4.7K	0.5%	1/16W	R675	1-220-804-11	RES-CHIP	2.2M	5%	1/16W
R478	1-218-961-11	RES-CHIP	4.7K	5%	1/16W	R678	1-218-990-11	SHORT CHIP	0		
						R679	1-218-945-11	RES-CHIP	220	5%	1/16W
R480	1-218-977-11	RES-CHIP	100K	5%	1/16W	R681	1-218-989-11	RES-CHIP	1M	5%	1/16W
R481	1-218-990-11	SHORT CHIP	0			R682	1-218-989-11	RES-CHIP	1M	5%	1/16W
R482	1-218-977-11	RES-CHIP	100K	5%	1/16W						
R484	1-218-981-11	RES-CHIP	220K	5%	1/16W	R683	1-218-989-11	RES-CHIP	1M	5%	1/16W
R486	1-218-990-11	SHORT CHIP	0			R684	1-218-965-11	RES-CHIP	10K	5%	1/16W
						R685	1-218-965-11	RES-CHIP	10K	5%	1/16W
R488	1-218-981-11	RES-CHIP	220K	5%	1/16W	R686	1-216-864-11	SHORT CHIP	0		
R489	1-218-941-11	RES-CHIP	100	5%	1/16W	R687	1-218-990-11	SHORT CHIP	0		
R490	1-218-941-11	RES-CHIP	100	5%	1/16W						
R491	1-218-941-11	RES-CHIP	100	5%	1/16W	R689	1-218-990-11	SHORT CHIP	0		
R492	1-218-985-11	RES-CHIP	470K	5%	1/16W	R690	1-216-864-11	SHORT CHIP	0		
						R691	1-218-990-11	SHORT CHIP	0		
R493	1-208-715-11	METAL CHIP	22K	0.5%	1/16W	R693	1-218-990-11	SHORT CHIP	0		
R494	1-208-715-11	METAL CHIP	22K	0.5%	1/16W	R707	1-218-957-11	RES-CHIP	2.2K	5%	1/16W
R495	1-208-935-11	METAL CHIP	100K	0.5%	1/16W						
R496	1-218-989-11	RES-CHIP	1M	5%	1/16W	R708	1-218-957-11	RES-CHIP	2.2K	5%	1/16W
R497	1-218-977-11	RES-CHIP	100K	5%	1/16W	R709	1-218-957-11	RES-CHIP	2.2K	5%	1/16W
						R710	1-218-965-11	RES-CHIP	10K	5%	1/16W
R499	1-218-981-11	RES-CHIP	220K	5%	1/16W	R711	1-218-965-11	RES-CHIP	10K	5%	1/16W
R501	1-218-957-11	RES-CHIP	2.2K	5%	1/16W	R712	1-218-965-11	RES-CHIP	10K	5%	1/16W
R502	1-218-953-11	RES-CHIP	1K	5%	1/16W						
R505	1-218-929-11	RES-CHIP	10	5%	1/16W	R713	1-218-953-11	RES-CHIP	1K	5%	1/16W
R513	1-218-965-11	RES-CHIP	10K	5%	1/16W	R801	1-218-961-11	RES-CHIP	4.7K	5%	1/16W
						R802	1-218-990-11	SHORT CHIP	0		
R514	1-218-973-11	RES-CHIP	47K	5%	1/16W	R804	1-218-933-11	RES-CHIP	22	5%	1/16W
R515	1-218-965-11	RES-CHIP	10K	5%	1/16W	R805	1-218-933-11	RES-CHIP	22	5%	1/16W
R516	1-218-973-11	RES-CHIP	47K	5%	1/16W						
R517	1-218-965-11	RES-CHIP	10K	5%	1/16W	R806	1-218-961-11	RES-CHIP	4.7K	5%	1/16W
R518	1-218-973-11	RES-CHIP	47K	5%	1/16W	R807	1-218-957-11	RES-CHIP	2.2K	5%	1/16W
						R808	1-218-957-11	RES-CHIP	2.2K	5%	1/16W
R519	1-218-953-11	RES-CHIP	1K	5%	1/16W	R810	1-218-990-11	SHORT CHIP	0		
R520	1-218-949-11	RES-CHIP	470	5%	1/16W	R811	1-218-965-11	RES-CHIP	10K	5%	1/16W
R524	1-218-945-11	RES-CHIP	220	5%	1/16W						
R525	1-216-864-11	SHORT CHIP	0			R812	1-218-977-11	RES-CHIP	100K	5%	1/16W
R526	1-216-864-11	SHORT CHIP	0			R813	1-218-990-11	SHORT CHIP	0		
						R814	1-218-990-11	SHORT CHIP	0		
R605	1-218-953-11	RES-CHIP	1K	5%	1/16W	R815	1-218-981-11	RES-CHIP	220K	5%	1/16W
R608	1-218-446-11	METAL CHIP	1	5%	1/10W	R817	1-218-953-11	RES-CHIP	1K	5%	1/16W
R612	1-220-804-11	RES-CHIP	2.2M	5%	1/16W						
R616	1-218-953-11	RES-CHIP	1K	5%	1/16W	R818	1-218-957-11	RES-CHIP	2.2K	5%	1/16W
R617	1-218-953-11	RES-CHIP	1K	5%	1/16W	R819	1-218-953-11	RES-CHIP	1K	5%	1/16W
						R820	1-218-945-11	RES-CHIP	220	5%	1/16W
R618	1-218-977-11	RES-CHIP	100K	5%	1/16W	R821	1-220-804-11	RES-CHIP	2.2M	5%	1/16W
R619	1-218-977-11	RES-CHIP	100K	5%	1/16W	R822	1-218-989-11	RES-CHIP	1M	5%	1/16W
R624	1-218-985-11	RES-CHIP	470K	5%	1/16W						
R625	1-218-985-11	RES-CHIP	470K	5%	1/16W	R823	1-218-965-11	RES-CHIP	10K	5%	1/16W
R628	1-218-933-11	RES-CHIP	22	5%	1/16W	R827	1-218-941-11	RES-CHIP	100	5%	1/16W
						R829	1-218-990-11	SHORT CHIP	0		
R629	1-220-804-11	RES-CHIP	2.2M	5%	1/16W	R834	1-218-985-11	RES-CHIP	470K	5%	1/16W
R645	1-218-985-11	RES-CHIP	470K	5%	1/16W	R835	1-208-943-11	METAL CHIP	220K	0.5%	1/16W
R646	1-218-973-11	RES-CHIP	47K	5%	1/16W						

MAIN

Ref. No.	Part No.	Description	Remark
R836	1-208-927-11	METAL CHIP	47K 0.5% 1/16W
R837	1-218-957-11	RES-CHIP	2.2K 5% 1/16W
R841	1-218-929-11	RES-CHIP	10 5% 1/16W
R842	1-218-973-11	RES-CHIP	47K 5% 1/16W
R843	1-218-957-11	RES-CHIP	2.2K 5% 1/16W
R854	1-208-927-11	METAL CHIP	47K 0.5% 1/16W
R857	1-218-985-11	RES-CHIP	470K 5% 1/16W
R858	1-218-929-11	RES-CHIP	10 5% 1/16W
R860	1-218-965-11	RES-CHIP	10K 5% 1/16W
R861	1-218-929-11	RES-CHIP	10 5% 1/16W
R865	1-218-989-11	RES-CHIP	1M 5% 1/16W
R866	1-218-989-11	RES-CHIP	1M 5% 1/16W
R868	1-218-990-11	SHORT CHIP	0
R872	1-218-965-11	RES-CHIP	10K 5% 1/16W
R873	1-218-965-11	RES-CHIP	10K 5% 1/16W
R877	1-218-989-11	RES-CHIP	1M 5% 1/16W
R878	1-218-937-11	RES-CHIP	47 5% 1/16W
R879	1-218-937-11	RES-CHIP	47 5% 1/16W
R880	1-218-937-11	RES-CHIP	47 5% 1/16W
R881	1-218-981-11	RES-CHIP	220K 5% 1/16W
R882	1-218-985-11	RES-CHIP	470K 5% 1/16W
R883	1-218-989-11	RES-CHIP	1M 5% 1/16W
R884	1-218-985-11	RES-CHIP	470K 5% 1/16W
R885	1-218-989-11	RES-CHIP	1M 5% 1/16W
R886	1-218-977-11	RES-CHIP	100K 5% 1/16W
R887	1-218-977-11	RES-CHIP	100K 5% 1/16W
R888	1-218-981-11	RES-CHIP	220K 5% 1/16W
R890	1-218-981-11	RES-CHIP	220K 5% 1/16W
R892	1-218-981-11	RES-CHIP	220K 5% 1/16W
R893	1-220-804-11	RES-CHIP	2.2M 5% 1/16W
R894	1-218-977-11	RES-CHIP	100K 5% 1/16W
R895	1-218-977-11	RES-CHIP	100K 5% 1/16W
R897	1-218-990-11	SHORT CHIP	0
R898	1-208-935-11	METAL CHIP	100K 0.5% 1/16W
R899	1-218-990-11	SHORT CHIP	0
R903	1-218-989-11	RES-CHIP	1M 5% 1/16W
R904	1-218-989-11	RES-CHIP	1M 5% 1/16W
R906	1-218-973-11	RES-CHIP	47K 5% 1/16W
R907	1-218-965-11	RES-CHIP	10K 5% 1/16W
R908	1-218-969-11	RES-CHIP	22K 5% 1/16W
R910	1-218-969-11	RES-CHIP	22K 5% 1/16W
R912	1-218-981-11	RES-CHIP	220K 5% 1/16W
R914	1-208-911-11	METAL CHIP	10K 0.5% 1/16W
R917	1-218-981-11	RES-CHIP	220K 5% 1/16W
R918	1-218-985-11	RES-CHIP	470K 5% 1/16W
R920	1-218-985-11	RES-CHIP	470K 5% 1/16W
R922	1-218-977-11	RES-CHIP	100K 5% 1/16W
R923	1-220-804-11	RES-CHIP	2.2M 5% 1/16W
R924	1-218-985-11	RES-CHIP	470K 5% 1/16W
R925	1-208-927-11	METAL CHIP	47K 0.5% 1/16W
R926	1-208-935-11	METAL CHIP	100K 0.5% 1/16W
R927	1-208-683-11	METAL CHIP	1K 0.5% 1/16W
R929	1-208-935-11	METAL CHIP	100K 0.5% 1/16W
R930	1-208-927-11	METAL CHIP	47K 0.5% 1/16W
R933	1-208-943-11	METAL CHIP	220K 0.5% 1/16W
R934	1-208-715-11	METAL CHIP	22K 0.5% 1/16W
R935	1-208-935-11	METAL CHIP	100K 0.5% 1/16W
R936	1-208-927-11	METAL CHIP	47K 0.5% 1/16W

Ref. No.	Part No.	Description	Remark
R937	1-208-715-11	METAL CHIP	22K 0.5% 1/16W
R938	1-208-927-11	METAL CHIP	47K 0.5% 1/16W
R939	1-218-977-11	RES-CHIP	100K 5% 1/16W
R957	1-208-943-11	METAL CHIP	220K 0.5% 1/16W
R960	1-218-990-11	SHORT CHIP	0
R961	1-220-803-81	RES-CHIP	4.7 5% 1/16W
R962	1-218-990-11	SHORT CHIP	0
R966	1-218-973-11	RES-CHIP	47K 5% 1/16W
R967	1-218-985-11	RES-CHIP	470K 5% 1/16W
R968	1-218-985-11	RES-CHIP	470K 5% 1/16W
R969	1-218-957-11	RES-CHIP	2.2K 5% 1/16W
R976	1-218-973-11	RES-CHIP	47K 5% 1/16W
R977	1-218-977-11	RES-CHIP	100K 5% 1/16W
R4460	1-218-990-11	SHORT CHIP	0
R6620	1-244-161-11	RES-CHIP	2.2 5% 1/16W
R6621	1-244-161-11	RES-CHIP	2.2 5% 1/16W
R6622	1-244-161-11	RES-CHIP	2.2 5% 1/16W
R6623	1-244-161-11	RES-CHIP	2.2 5% 1/16W
R6694	1-218-929-11	RES-CHIP	10 5% 1/16W
R6695	1-218-990-11	SHORT CHIP	0
R8813	1-218-990-11	SHORT CHIP	0
R8891	1-218-953-11	RES-CHIP	1K 5% 1/16W
R8892	1-218-953-11	RES-CHIP	1K 5% 1/16W
< SWITCH >			
S890	1-786-691-21	SWITCH, PUSH (1 KEY) (PROTECT DETECT)	
S891	1-786-692-21	SWITCH, PUSH (1 KEY) (HI-MD PROTECT DETECT)	
S892	1-762-946-12	SWITCH, PUSH (1 KEY) (HLAF LOCK)	
S893	1-762-805-21	SWITCH, PUSH (1 KEY) (OPEN/CLOSE DETECT)	
* S894	1-786-079-21	SWITCH, PUSH (1 KEY) (BATTERY INSERT DETECT)	
S895	1-762-078-11	SWITCH, SLIDE (HOLD)	
< THERMISTOR >			
THP401	1-805-580-11	THERMISTOR, POSITIVE	
TH801	1-805-194-21	THERMISTOR, NTC (SMD)	
< VARISTOR >			
VDR8801	1-805-697-21	VARISTOR (SMD)	
< VIBRATOR >			
X801	1-813-353-21	VIBRATOR, CERAMIC (48MHz)	
X802	1-795-728-21	VIBRATOR, CRYSTAL (22.5792MHz)	

<p>The components identified by mark Δ or dotted line with mark Δ are critical for safety. Replace only with part number specified.</p>	<p>Les composants identifiés par une marque Δ sont critiques pour la sécurité. Ne les remplacer que par une pièce portant le numéro spécifié.</p>
---	---

Ref. No.	Part No.	Description	Remark
		MISCELLANEOUS *****	
54	A-1104-960-A	SWITCH UNIT ASSY	
△ 163	X-2055-677-1	OP SERVICE ASSY (ABX-UJ) (including HR601(OVER WRITE HEAD))	
M701	8-835-782-12	MOTOR, DC SSM18D/G-NP (SPINDLE)	
M702	1-787-143-11	MOTOR, DC (SLED)	
M703	1-477-519-21	MOTOR UNIT, DC (OVER WRITE HEAD UP/DOWN)	

		ACCESSORIES *****	
	1-400-877-11	FILTER, CLAMP (FERRITE CORE) (for remote control, stereo microphone, line cable) (EXCEPT E, JE)	
△	1-569-007-12	ADAPTOR, CONVERSION 2P (JE)	
	1-816-206-11	CONNECTOR, LIGHT (AEP, UK, E, EE, AUS)	
	1-816-206-21	CONNECTOR, LIGHT (HK, KR, JE)	
	2-588-601-11	MANUAL, INSTRUCTION (ENGLISH) (EXCEPT KR)	
	2-588-601-21	MANUAL, INSTRUCTION (FRENCH) (CND, AEP)	
	2-588-601-31	MANUAL, INSTRUCTION (GERMAN) (AEP)	
	2-588-601-41	MANUAL, INSTRUCTION (SPANISH) (AEP, JE)	
	2-588-601-51	MANUAL, INSTRUCTION (DUTCH) (AEP)	
	2-588-601-61	MANUAL, INSTRUCTION (SWEDISH) (AEP)	
	2-588-601-71	MANUAL, INSTRUCTION (ITALIAN) (AEP)	
	2-588-601-81	MANUAL, INSTRUCTION (PORTUGUESE) (AEP, JE)	
	2-588-601-91	MANUAL, INSTRUCTION (FINNISH) (AEP)	
	2-588-602-11	MANUAL, INSTRUCTION (CZECH) (EE)	
	2-588-602-21	MANUAL, INSTRUCTION (HUNGARIAN) (EE)	
	2-588-602-31	MANUAL, INSTRUCTION (POLISH) (EE)	
	2-588-602-41	MANUAL, INSTRUCTION (SLOVAKIAN) (EE)	
	2-588-602-51	MANUAL, INSTRUCTION (RUSSIAN) (EE)	
	2-588-602-61	MANUAL, INSTRUCTION (TRADITIONAL CHINESE) (E, HK, JE)	
	2-588-602-71	MANUAL, INSTRUCTION (SIMPLIFIED CHINESE) (JE)	
	2-588-602-81	MANUAL, INSTRUCTION (KOREAN) (KR, JE)	
	3-220-749-01	CASE, CARRYING	
	X-2050-995-1	CD-ROM (APPLICATION) ASSY (SonicStage/MD Simple Burner)	
△ 501	1-478-846-11	ADAPTOR, AC (AC-ES3010K2) (US, CND)	
△ 501	1-478-847-11	ADAPTOR, AC (AC-ES3010K2) (KR)	
△ 501	1-478-848-11	ADAPTOR, AC (AC-ES3010K2) (AEP, E, EE)	
△ 501	1-478-849-11	ADAPTOR, AC (AC-ES3010K2) (UK, HK)	
△ 501	1-478-850-11	ADAPTOR, AC (AC-ES3010K2) (AUS)	
△ 501	1-478-853-12	ADAPTOR, AC (AC-ES3010K2) (JE)	
502	1-479-321-11	REMOTE COMMANDER (RM-MC60)	
503	8-912-742-91	EARPHONES MDR-E0931SPB9 SET (JE)	
503	8-912-743-90	EARPHONES MDR-E808SPB19 SET (EXCEPT JE)	
504	1-830-472-11	CORD, CONNECTION (USB)	
505	1-756-120-23	BATTERY, NICKEL HYDROGEN (NH-14WM) (EXCEPT US, CND)	
505	1-756-120-61	BATTERY, NICKEL HYDROGEN (NH-14WM) (US, CND)	
506	3-008-521-01	CASE, CHARGE	

Ref. No.	Part No.	Description	Remark
507	1-417-577-11	CASE, BATTERY	
509	1-400-878-11	FILTER, CLAMP (FERRITE CORE) (for AC POWER ASAPTOR, DEDICATED USB CABLE)	

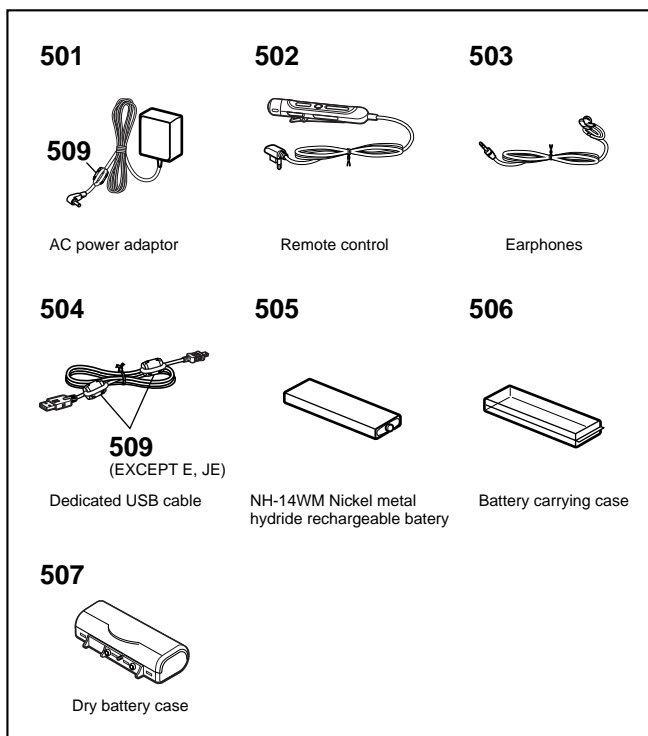

The components identified by mark △ or dotted line with mark △ are critical for safety. Replace only with part number specified.

Les composants identifiés par une marque △ sont critiques pour la sécurité. Ne les remplacer que par une pièce portant le numéro spécifié.

