

# *Personal MiniDisc System*

---

## Operating Instructions

### Owner's Record

The model number and the serial number are located on the right side.

Record the serial number in the space provided below. Refer to these numbers whenever you call upon your Sony dealer regarding this product.

Model No. PMC-MD55

Serial No. \_\_\_\_\_



## *PMC-MD55*

## Warning

To prevent fire or shock hazard, do not expose the player to rain or moisture.

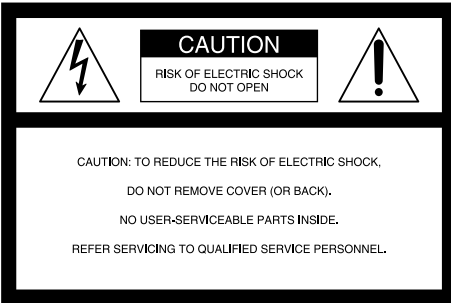

This symbol is intended to alert the user to the presence of uninsulated “dangerous voltage” within the product’s enclosure that may be of sufficient magnitude to constitute a risk of electric shock to persons.



This symbol is intended to alert the user to the presence of important operating and maintenance (servicing) instructions in the literature accompanying the appliance.

## CAUTION

The use of optical instruments with this product will increase eye hazard.

## WARNING

Do not install the appliance in a confined space, such as a bookcase or built-in cabinet.

## Information

For customers in the United States

This equipment has been tested and found to comply with the limits for a Class B digital device, pursuant to Part 15 of the FCC Rules. These limits are designed to provide reasonable protection against harmful interference in a residential installation. This equipment generates, uses and can radiate radio frequency energy and, if not installed and used in accordance with the instructions, may cause harmful interference to radio communications. However, there is no

guarantee that interference will not occur in a particular installation. If this equipment does cause harmful interference to radio or television reception, which can be determined by turning the equipment off and on, the user is encouraged to try to correct the interference by one or more of the following measures:

- Reorient or relocate the receiving antenna.
- Increase the separation between the equipment and receiver.
- Connect the equipment into an outlet on a circuit different from that to which the receiver is connected.
- Consult the dealer or an experienced radio/TV technician for help.

You are cautioned that any changes or modifications not expressly approved in this manual could void your authority to operate this equipment.

## CAUTION

- You can use this player on AC power source only. You cannot use it on batteries. When you use this player for the first time, or when you have not used it for a long time, leave it connected to AC power source for about one hour to charge the built-in backup battery for the clock, timer, preset radio stations, etc. You can use the player during charging. The player will charge the battery automatically as long as it is connected to a power source.

When you disconnect the AC power cord after charging, be sure to turn the power off first. Once fully charged, the backup battery will last for about 30 minutes without being connected to any power sources.

If the stored data are erased, reenter them when you use the player again.

- Do not put foreign objects in the duct of the super woofer. If a foreign object should enter the super woofer’s duct, turn off the power and contact your nearest Sony service station immediately.
- The speakers, super woofer, and player are designed to be used as a single unit. Never connect the speakers, super woofer, and player to different equipment. Doing so may cause the connected equipment to malfunction.

# Table of contents

## Basic Operations

- 4 Playing a CD
- 6 Recording a whole CD (Synchronized recording)
- 8 Playing an MD
- 10 Listening to the radio

### The CD Player•The MD Player

- 12 Using the display
- 16 Checking CD text information
- 18 Locating a specific track
- 19 Playing tracks repeatedly (Repeat Play)
- 20 Creating your own program (Program Play)
- 22 Playing tracks in random order (Shuffle Play)

### The Radio

- 23 Presetting radio stations
- 25 Playing preset radio stations

### Recording

- 26 Recording the track you are listening to (Synchronized recording of a single track - REC IT)
- 27 Recording the tracks you programmed (Synchronized recording of the tracks you programmed)
- 29 Recording from the radio or a CD
- 31 Recording on a recorded MD

### Editing recorded tracks on the MD

- 32 Before editing
- 34 Erasing recordings (Erase Function)
- 37 Dividing recorded tracks (Divide Function)
- 39 Combining recorded tracks (Combine Function)
- 41 Moving recorded tracks (Move Function)
- 42 Labeling recordings (Name Function)

### The Timer

- 46 Setting the clock
- 48 Waking up to music
- 50 Timer-recording radio programs
- 52 Falling asleep to music

### Setting Up

- 53 Hooking up the system
- 59 Connecting optional components
- 61 Using the super woofer
- 62 Adjusting the audio emphasis

### Additional Information

- 63 Precautions
- 65 System limitations of the MD
- 67 Getting to know the MD
- 69 Troubleshooting
- 72 Error messages
- 73 Specifications
- 75 Index

# Playing a CD

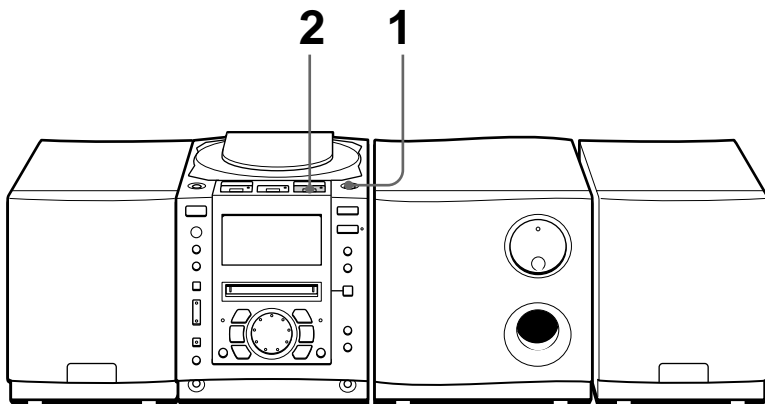

For hookup instructions, see pages 53 - 58.

1

CD  
OPEN/CLOSE



Press ▲ CD OPEN/CLOSE (direct power-on) and place the CD on the CD compartment.



With the label side up

2



Press CD ►► (CD ► on the remote).

The lid of the CD compartment closes and the player plays all the tracks once.

Display

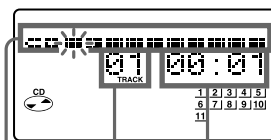

Position  
pointer

Track  
number

Playing  
time

## Use these buttons for additional operations

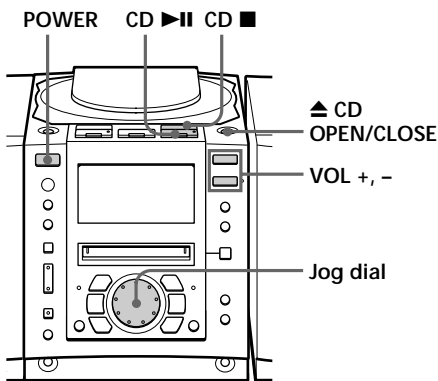

## Tips

- Next time you want to listen to a CD, just press CD ►||. The player turns on automatically and starts playing the CD.
- **What is the position pointer in the display?** It shows about where on the CD track the player is playing.
- When opening or closing the lid of the CD compartment, be careful not to pinch your fingers, etc., between the lid and the player. If pinched, press ▲ CD OPEN/CLOSE again to open the lid.

To	Do this
adjust the volume	Press VOL +, -
stop playback	Press CD ■
pause playback	Press CD ►   (CD    on the remote). Press the button again to resume play after pause.
go to the next track	Turn the jog dial clockwise. (On the remote, press ►►)
go back to the previous track	Turn the jog dial counterclockwise. (On the remote, press ◀◀)
remove the CD	Press ▲ CD OPEN/CLOSE.
turn on/off the player	Press POWER.

# Recording a whole CD

## (Synchronized recording)

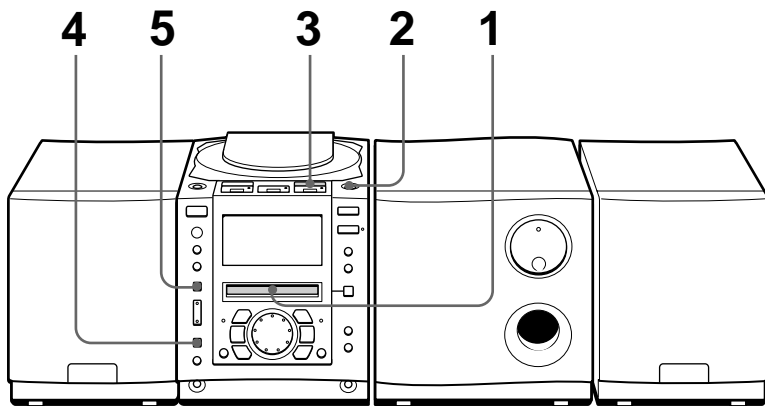

For hookup instructions, see pages 53 - 58.

**1**

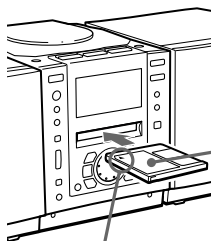

Insert in the direction of the arrow

Insert a recordable MD (direct power-on).

With the label side up

Display

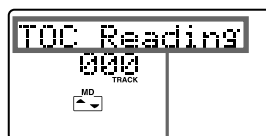

After "TOC Reading" is displayed, the disc name will be displayed if it is labeled.

**2**

CD OPEN/CLOSE



Press ▲ CD OPEN/CLOSE and place the CD on the CD compartment.

Press ▲ CD OPEN/CLOSE again to close the CD compartment.

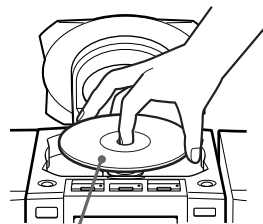

With the label side up

**3**

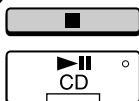

Press CD ■.

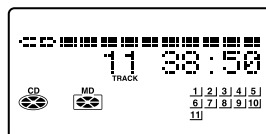



To record at high speed, press HIGH SPEED.

The indicator on the button lights up.

To record at normal speed, skip this step.

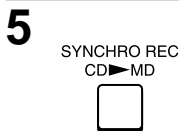

Press SYNCHRO REC CD ►

Position pointer (showing playing position on the CD and recording position on the MD)

The player starts recording automatically.

If the MD has any previous recording, recording will be made from the last recorded position.

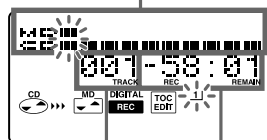

Track number of MD

Remaining recording time of MD

**Notes**

- **TOC EDIT** After you stop recording, do not disconnect the AC power cord or move the player while "TOC EDIT" is flashing in the display. If you do so, recording may not be done properly.
- When you record a whole CD, you cannot pause recording.

**Tips**

- Adjusting the volume or the audio emphasis (page 62) will not affect the recording level. Keep the volume at a moderate level so as to prevent the sound from skipping.
- To record over the previous recording, see page 31.
- Once the clock is set, the recording date and time are stamped automatically (page 46).
- You can label an MD or a track during recording (page 42).

**Use these buttons for additional operations**

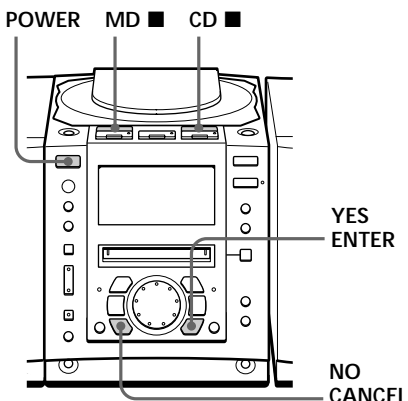

To	Press
stop recording	MD ■ or CD ■
turn on/off the player	POWER

If "CD>MD OK?" alternates with time display  
 There is not enough space on the MD to record the whole CD.  
 If it is all right to record as much as possible and cancel recording of some tracks, press YES • ENTER. To stop recording, press NO • CANCEL.  
 If any other messages are displayed, see page 72.

# Playing an MD

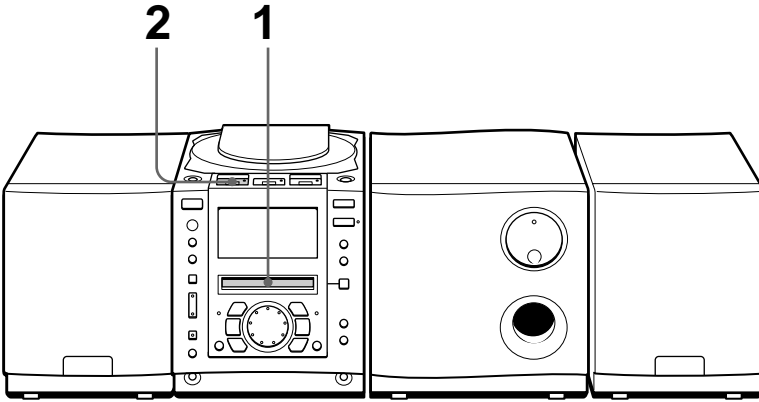

For hookup instructions, see pages 53 - 58.

**1**

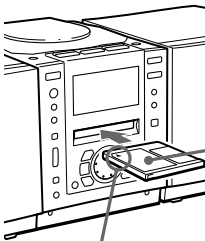

Insert in the direction of the arrow

Insert the MD (direct power-on).

With the label side up

Display

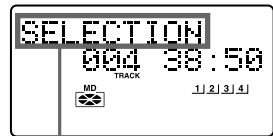

After "TOC Reading" is displayed, the disc name will be displayed if it is labeled.

**2**



Press MD ►|| (MD ► on the remote).

The player plays all the tracks once.

Track name is displayed if it is labeled.

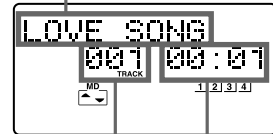

Track number      Playing time

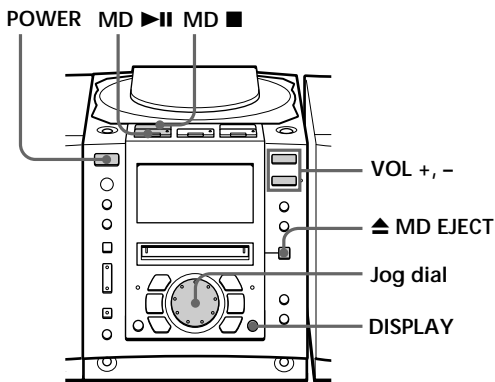

## Use these buttons for additional operations

**Tip**

Next time you want to listen to an MD, just press MD ►||. The player turns on automatically and starts playing the MD.

To	Do this
adjust the volume	Press VOL +, -
stop playback	Press MD ■
pause playback	Press MD ►   (MD    on the remote). Press the button again to resume play after pause.
go to the next track	Turn the jog dial clockwise. (On the remote, press ►  )
go back to the previous track	Turn the jog dial counterclockwise. (On the remote, press ◀  )
remove the MD	Press ▲ MD EJECT.
turn on/off the player	Press POWER.
check the playing position in the display using the position pointer	Press DISPLAY.

# Listening to the radio

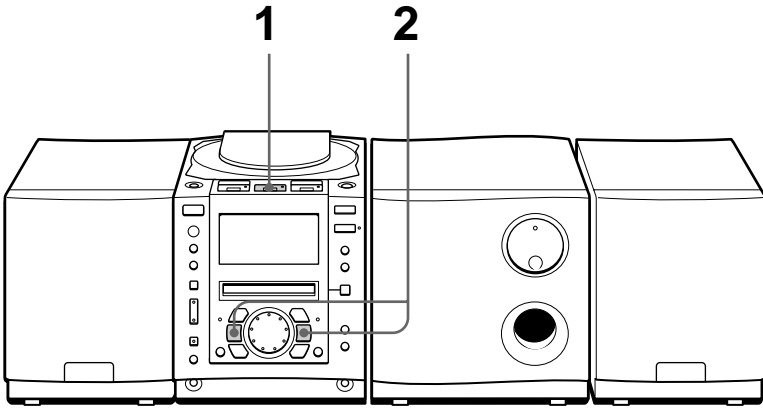

For hookup instructions, see pages 53 - 58.

**1**



Press **RADIO BAND** until the band you want appears in the display (direct power-on).

Display

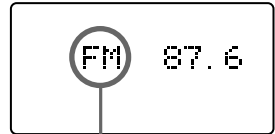

"FM" or "AM" appears

**2**

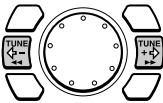

Hold down **TUNE +** or **TUNE -** until the frequency digits begin to change in the display.

The player automatically scans the radio frequencies and stops when it finds a clear station.

If you can't tune in a station, press **TUNE +** or **TUNE -** repeatedly to change the frequency step by step.

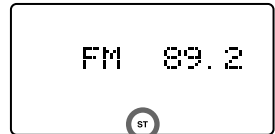

Indicates an FM stereo broadcast

## Use these buttons for additional operations

## POWER

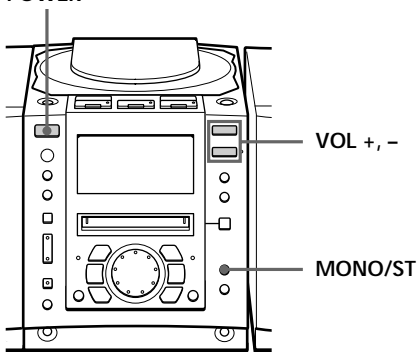

## Tips

- If the FM broadcast is noisy, press MONO/ST (MODE on the remote) until “Mono” appears in the display and radio will play in monaural.
- Next time you want to listen to the radio, just press RADIO BAND. The player turns on automatically and starts playing the previous station.

To	Press
adjust the volume	VOL +, -
turn on/off the radio	POWER

## To improve broadcast reception

## FM:

Connect the supplied FM lead antenna.

If the FM broadcast is still noisy, disconnect the FM lead antenna and connect the FM outdoor antenna (not supplied) (see page 58).

## AM:

Keep the AM loop antenna as far as possible from the player and reorient it.

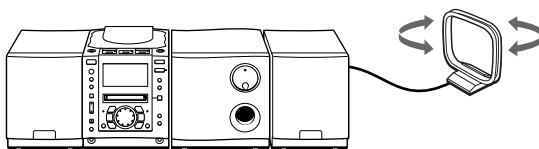

If the broadcast is still noisy, connect the external antenna (page 58).

# Using the display

You can check information about the CD and MD using the display.

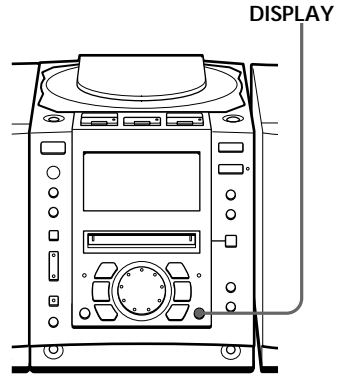

## Tip

When using the CD containing text information, the disc name, the artist name, etc. appear in the display (page 16).

## During stop (CD)

The total track number and playing time are displayed.

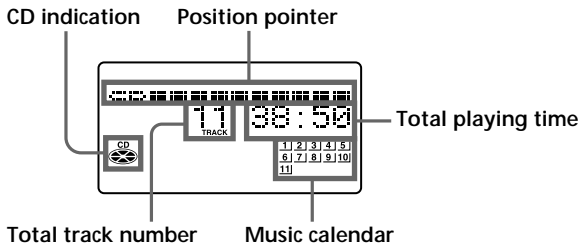

If the CD has more than 20 tracks, "OVER 20" appears in the display.

**Note**

During repeat play (page 19), program play (page 20) and shuffle play (page 22), the number of tracks left and remaining time on the CD will not be displayed.

**During play (CD)**

The current track number and playing time are displayed. The track numbers in the music calendar disappear after they are played.

**To check the remaining time**

Press DISPLAY.

To display	Press DISPLAY
the current track number and remaining time on the current track	once
the number of tracks left and remaining time on the CD	twice
the current track number and playing time	three times

continued

## Using the display (continued)

### Tip

The disc name or the track name is displayed only with the MDs that have been electronically labelled.

### During stop (MD)

The total track number and playing time are displayed.

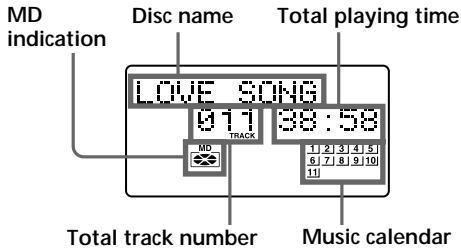

If the MD has more than 20 tracks, "OVER 20" appears in the display.

To check the remaining recording time on the MD  
Press DISPLAY.

The position pointer also appears in the display.

**Note**

During repeat play (page 19), program play (page 20) and shuffle play (page 22), the number of tracks left and remaining time on the MD will not be displayed.

**During play (MD)**

The current track number, playing time and the track name are displayed. The track numbers in the music calendar disappear after they are played.

To check the remaining time, recording date and time, etc.

Press DISPLAY.

To display	Press DISPLAY
the current track number, remaining time on the current track and position pointer	once
the number of tracks left, remaining time on the MD and the disc name	twice
recording date and time*	three times
the current track number, playing time and the track name	four times

\* Once the clock is set, the recording date and time are stamped automatically (page 46).

# Checking CD text information

You can display the CD text (the disc name, the artist name, the track name, etc.) when this information is recorded on the CD.

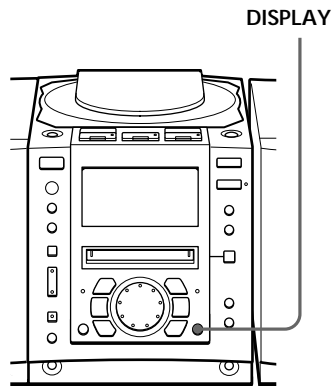

## Tips

-  This mark appears on the CD, the CD case, etc., when the CD contains text information.
- This player can display up to 1,500 characters of text information per CD. If a CD has text information of more than 1,500 characters, the excess characters will be omitted.

## During stop (CD)

The total track number and playing time are displayed.

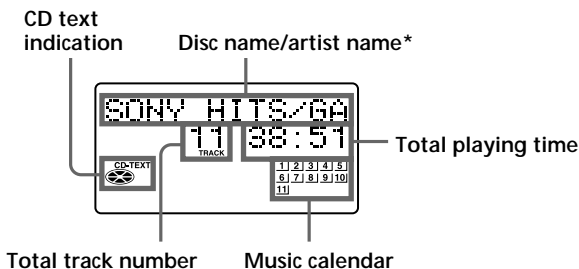

\* If you press DISPLAY once, the position pointer is displayed. If you press it twice, the display returns to the initial one.



**During play (CD)**

The current track name, the current track number and playing time are displayed.

If you press DISPLAY, indications in the display changes as follows:

To display	Press DISPLAY
the position pointer, the current track number and remaining time on the current track	once
the disc name/artist name, the number of tracks left and remaining time on the CD	twice
the current track name, the current track number and playing time	three times

# Locating a specific track

You can quickly locate any track on a CD or an MD using the number buttons on the remote. You can also find a specific point in a track while playing a CD or an MD.

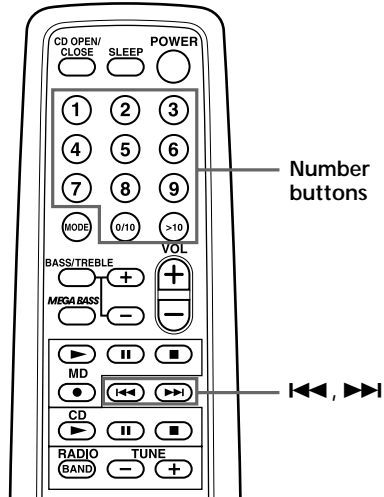

## Note

You cannot locate a specific track if “REP PGM”, “REP SHUF”, “PGM” or “SHUF” is lit in the display. Turn off the indication by pressing ■.

## Tips

- To locate a track numbered over 10, press >10 first, then the corresponding number buttons.  
Example:  
To play the track number 23, press >10 first, then 2 and 3.  
To play the track number 10, you can use the 0/10 button as well as >10, 1 and 0.
- To select a track on an MD numbered 100 or more, press >10 twice, then the corresponding number buttons.

To locate	Press
a specific track directly	the number button of the track.
a point while listening to the sound	▶▶▶ (forward) or ◀◀◀ (backward) while playing and hold down until you find the point. (On the player, use ▶▶▶ or ◀◀◀.)
a point while observing the display	▶▶▶ (forward) or ◀◀◀ (backward) in pause and hold down until you find the point. (On the player, use ▶▶▶ or ◀◀◀.)

# Playing tracks repeatedly

## (Repeat Play)

You can play tracks repeatedly in normal, shuffle or program play modes (page 20).

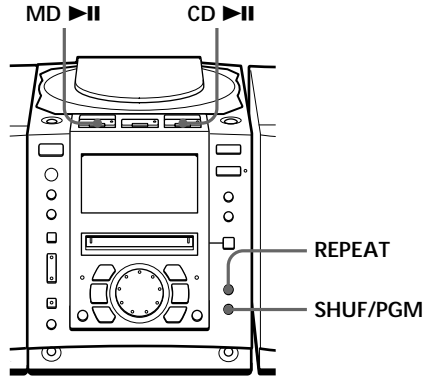

### On the remote

During stop, press MODE repeatedly until "REP 1", "REP ALL", "REP SHUF" or "REP PGM" appears in the display. Then play the CD or the MD.

You can also select "REP 1" or "REP ALL" during play.

To repeat	Do this
a single track	<ol style="list-style-type: none"> <li>1 Play the track you want.</li> <li>2 Press REPEAT until "REP 1" appears in the display.</li> </ol>
all the tracks	<ol style="list-style-type: none"> <li>1 Start normal play.</li> <li>2 Press REPEAT until "REP ALL" appears in the display.</li> </ol>
tracks in random order	<ol style="list-style-type: none"> <li>1 Start shuffle play (page 22).</li> <li>2 Press REPEAT until "REP SHUF" appears in the display.</li> </ol>
programmed tracks	<ol style="list-style-type: none"> <li>1 Start program play (page 20).</li> <li>2 Press REPEAT until "REP PGM" appears in the display.</li> </ol>

### To cancel Repeat Play

Stop play first. Then, press REPEAT until "REP" disappears from the display.

# Creating your own program

## (Program Play)

You can arrange the playing order of up to 20 tracks on a CD or an MD.

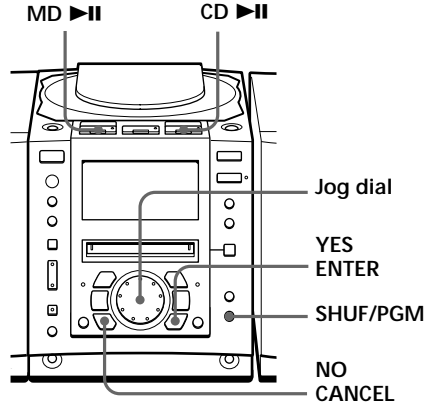

### On the remote

Press MODE until "PGM" appears in the display, then press the number button to select the track.

### Tip

If you made a mistake, press NO • CANCEL and re-enter the track number by turning the jog dial and press YES • ENTER.

Before you begin, make sure that the CD or MD player is in stop mode.

- 1 Press SHUF/PGM until "PGM" appears in the display.
- 2 Turn the jog dial to select the track you want to program, and press YES • ENTER.

Repeat this step.

Programed tracks appear in the music calendar.

(In case of CD)

Playing order    Total programed time

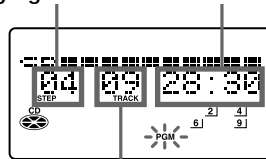

Track number

(In case of MD)

Playing order    Total programed time

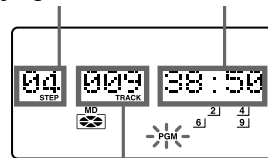

Track number

- 3 Press CD ►|| or MD ►|| to start program play.

### Tips

- If the program play is finished, the program is saved. You can play the same program again by pressing ►II.
- The program is erased:
  - if you open the lid of the CD compartment or
  - if you take out the MD.
- During play, total programmed time cannot be displayed.

### To cancel Programme Play

Stop play first. Then, press SHUF/PGM until “PGM” disappears from the display.

### To check the order of tracks before play

Before starting the program play, press YES • ENTER.

“PGM Check” appears in the display. Every time you press YES • ENTER, the track number appears in the programmed order.

### To change the current program

Change before starting the program play.

To	Do this
erase the last track in the program	<ol style="list-style-type: none"> <li>1 Press NO • CANCEL. The track programmed last is erased.</li> <li>2 Re-enter the track numbers by turning the jog dial and pressing YES • ENTER.</li> </ol>
change the whole program completely	<ol style="list-style-type: none"> <li>1 Press ■ to erase the whole program.</li> <li>2 Create a new program following the programming procedure.</li> </ol>

# Playing tracks in random order

## (Shuffle Play)

You can play tracks in random order.

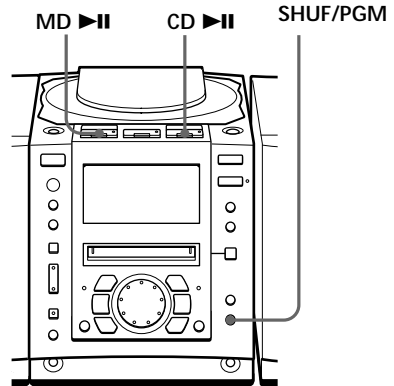

### Tip

During shuffle play, you cannot select the previous track by turning the jog dial (or by pressing **◀◀** on the remote).

### On the remote

Press MODE until "SHUF" appears in the display.

Before you begin, make sure that the CD or MD player is in stop mode.

- 1 Press SHUF/PGM until "SHUF" appears in the display.
- 2 Press CD **▶|** or MD **▶|** to start shuffle play.

### To cancel Shuffle Play

Stop play first. Then, press SHUF/PGM until "SHUF" disappears from the display.

# Presetting radio stations

You can store radio stations into the player's memory. You can preset up to 20 stations, 10 for each band in any order.

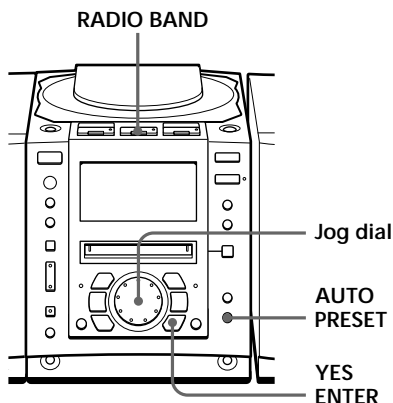

- 1** Press RADIO BAND until the band you want appears in the display.
- 2** Hold down AUTO PRESET until "Auto Preset" flashes in the display.

The stations are stored in memory from the lower frequencies (from the preset number 1, in numerical order) as long as the station has a signal strong enough.

When you've done presetting, the station stored in the preset number 1 will be tuned in automatically.

## On the remote

- 1** Press BAND until the band you want appears in the display.
- 2** Press TUNE + or - until you tune in the station you want.
- 3** Hold down the number button that you want to preset the new station on for 2 seconds.

## If a station cannot be preset automatically

You need to preset a station with a weak signal manually. Also, when you want to replace preset stations with a new one, proceed as follows:

- 1** Press RADIO BAND until the band you want appears in the display.
- 2** Press TUNE + or TUNE - repeatedly until you tune in the station you want, and then, hold down YES • ENTER for 2 seconds.
- 3** Select the preset number you want to preset the new station on by turning the jog dial.
- 4** Press YES • ENTER.

The new station replaces the old one.

continued

## Presetting radio stations (continued)

### The characters you can input

- Uppercase letters:  
ABCD.....WXYZ',/:  
□ (space)
- Lowercase letters:  
abcd.....wxyz',/:  
□ (space)
- Numbers and symbols:  
0123456789!#"#\$%&()\*.,;  
<=>? @\_`+ -',/:  
□ (space)

### To label the preset station

- 1 According to the procedure on page 25, tune in the station you want to label.
- 2 Press EDIT for 2 seconds.
- 3 Input the name of the station (up to 12 characters).  
For details, see step 3 on page 43.

To	Do this
move the cursor	Press ← or →.
select the characters	Turn the jog dial.
erase the characters	Press DELETE.
insert the characters	Use INSERT.

- 4 Press YES • ENTER.



# Playing preset radio stations

Once you've preset the stations, use the jog dial on the player or the number buttons on the remote to tune in your favorite stations.

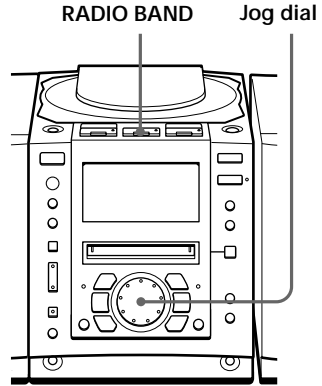

## On the remote

- 1 Press BAND until the band you want appears in the display.
- 2 Press the number button to tune in a stored station.

- 1 Press RADIO BAND until the band you want appears in the display.
- 2 Turn the jog dial to display the preset number of the station you want.

# Recording the track you are listening to

(Synchronized recording of a single track – REC IT)

You can record the track you are listening to from its beginning using the TO TOP or TO END button.

REC IT  
TO TOP  
TO END HIGH SPEED

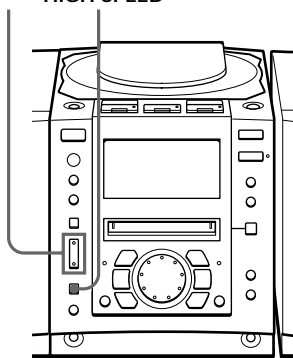

## Notes

-  After you stop recording, do not disconnect the AC power cord or move the player while "TOC EDIT" is flashing in the display. If you do so, recording may not be done properly.
- If you turn up the volume too high, sound skipping may occur.

## Tips

- To record over the previous recording, see page 31.
- Once the clock is set, the recording date and time are stamped automatically (page 46).
- You can label the track during recording (page 42).

- 1 Insert a recordable MD.
- 2 Insert the CD and play the track you want to record.
- 3 To record at high speed, press HIGH SPEED. The indicator on the button lights up. To record at normal speed, skip this step.
- 4 Press TO TOP or TO END of REC IT. The player goes back to the beginning of the track you are listening to, and starts recording.
 

When you use a recorded MD:

To record before the previous recording, press TO TOP.

To record after the previous recording, press TO END.

When you use a new MD:

Press either TO TOP or TO END.

When recording is finished, MD player will stop operation automatically but CD player will continue play.

# Recording the tracks you programmed

(Synchronized recording of the tracks you programmed)

You can record the tracks you programmed.

## Tip

If you made a mistake, press NO•CANCEL and re-enter the track number using the jog dial and YES•ENTER.

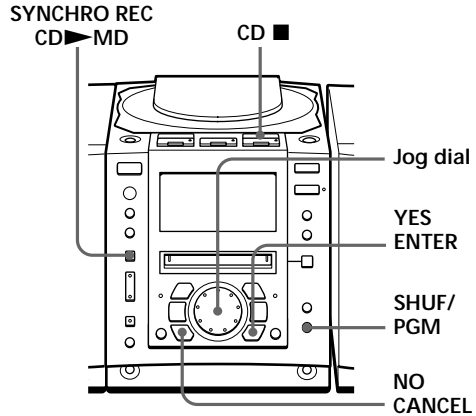

- 1 Insert a recordable MD.
- 2 Insert the CD you want to record and press CD ■.
- 3 Press SHUF/PGM until “PGM” appears in the display.
- 4 Turn the jog dial to select the track you want to program, and press YES•ENTER.

Repeat this step.

Programed tracks appear in the music calendar.

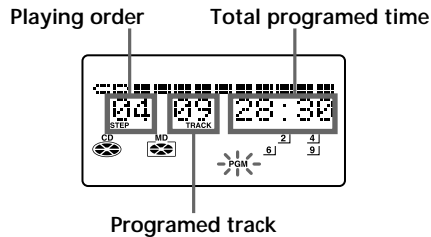

- 5 Press SYNCHRO REC CD ► MD.  
The player starts recording automatically.  
If the MD has any previous recording, recording will be made from the last recorded position.

continued

---

## Recording the tracks you programed (Synchronized recording of the tracks you programed) (continued)

### Notes

-  After you stop recording, do not disconnect the AC power cord or move the player while "TOC EDIT" is flashing in the display. If you do so, recording may not be done properly.
- If you turn up the volume too high, sound skipping may occur.

### Tips

- To record over the previous recording, see page 31.
- Once the clock is set, the recording date and time are stamped automatically (page 46).
- You can label the MD and the track during recording (page 42).

### If "CD>MD OK?" alternates with time display

There is not enough space on the MD to record the whole program.

If it is all right to record as much as possible and cancel recording of some tracks, press YES•ENTER. To stop recording, press NO•CANCEL.

If any other messages are displayed, see page 72.

# Recording from the radio or a CD

You can record from the radio or a CD to an MD using the REC button. You can start or stop recording at any point you want. You can also pause recording.

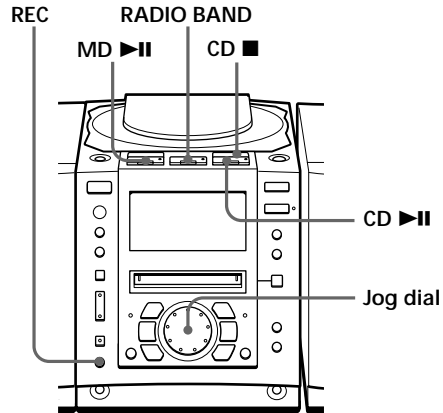

## Notes

-  After you stop recording, do not disconnect the AC power cord or move the player while "TOC EDIT" is flashing in the display. If you do so, recording may not be done properly.
- While recording from radio, you cannot change the station.
- If you turn up the volume too high, sound skipping may occur.

## Tips

- To record over the previous recording, see page 31.
- To add track marks during recording, press REC where you want to add track marks.
- To add track marks after recording, see "Dividing recorded tracks" on page 37.

## Recording from the radio

When receiving conditions are good, track marks are added on the MD automatically:

- when there is no sound input during recording for more than 2 seconds.
- when a soft sound like pianissimo continues during recording.
- when you pause recording.

If unnecessary track marks are added, erase them after recording (see "Combining recorded tracks" on page 39).

- 1 Tune in the station you want to record from.
- 2 Insert a recordable MD.
- 3 Press REC (● on the remote).  
The player stands by for recording.
- 4 Press MD >|| (MD > or MD || on the remote).  
Recording will be made from the last recorded position.

## To stop recording

Press MD ■.

continued

---

## Recording from the radio or a CD (continued)

### Tip

When you record a program of a station whose name is labeled on this player, the station name is recorded automatically as the track name (up to 50 names) (page 24).

### Notes

-  After you stop recording, do not disconnect the AC power cord or move the player while "TOC EDIT" is flashing in the display. If you do so, recording may not be done properly.
- If you turn up the volume too high, sound skipping may occur.

### Tips

- To record over the previous recording, see page 31.
- To add track marks during recording, press REC where you want to add track marks.
- To add track marks after recording, see "Dividing recorded tracks" on page 37.

### To pause recording

Press MD ►|| (MD || on the remote). Press the button again to resume recording.

### Recording from a CD

Track marks on the source CD are recorded on the same positions on the MD. Track marks are also added automatically on the MD when you pause recording.

If unnecessary track marks are added, erase them after recording (see "Combining recorded tracks" on page 39).

- 1 Insert a CD.
- 2 Press CD ■ to activate the CD player.
- 3 Insert a recordable MD.
- 4 Press REC (● on the remote).  
The player stands by for recording.
- 5 Press MD ►|| (MD ► or MD || on the remote).  
Recording will be made from the last recorded position.
- 6 Press CD ►||.

### To stop recording

Press MD ■.

### To pause recording

Press MD ►|| (MD || on the remote). Press the button again to resume recording.

# Recording on a recorded MD

There are two ways of recording on a recorded MD.

- To add to the previous recording. The previous recording will remain.
- To record over the previous recording. The previous recording will be erased.

## Adding recording (the previous recording will remain)

Insert a recorded MD, and start recording (pages 6, 29 and 30). Recording will be made from the last recorded position.

## If there is not enough space on the MD to record

When recording a whole CD, “CD>MD OK?” appears in the display (page 7). When recording from the radio or a CD, press DISPLAY to check the recording remaining time on the MD.

## Recording over the previous recording (the previous recording will be erased)

To record over from the beginning of the MD after erasing all tracks on the MD

First, erase all tracks on an MD (page 35). You can use the MD the same as a new one. Then, record on the MD as usual.

## To record over from a specific point on the MD

- 1 Play the MD and press MD ►|| to pause play at the point you want to start recording.
- 2 Press REC to make the player in standby mode.
- 3 Play the sound source.
- 4 Press MD ►|| to start recording.

## Note

When recording over from a specific point on the MD:

If the new recording is shorter than the previous recording, a part of the previous recording will remain after the recording. As you repeat this type of recording, many fragments of recording will remain on the MD. We recommend that you erase all tracks on the MD (page 35) if you no longer need to keep the recording. Then, start recording on the blank MD.

# Before editing

On the MD, track marks are inserted between the tracks. You can find the beginning of the tracks quickly using the track marks. You can change the positions of the track marks. For instance, you can divide a certain track into several tracks by adding track marks. You can also combine some tracks into a new longer track by erasing some track marks.

**The position of the track marks to be added are different depending on the type of recording or recording conditions**

The type of recording	The position of the track marks to be added
Recording a whole CD (page 6)	The same positions on the source CD
Recording from a CD using REC button (page 30)	<ul style="list-style-type: none"> <li>• The same positions on the source CD</li> <li>• The position where you pause recording</li> <li>• The position where you press REC</li> </ul>
Recording from the radio or other equipment connected to the player (pages 29 and 60)	<ul style="list-style-type: none"> <li>• When there is no sound input or a soft sound continues during recording for more than 2 seconds</li> <li>• The positions where you pause recording</li> <li>• The positions where you press REC</li> </ul>

You can add or erase track marks after recording. When you record, for instance, from a radio or other equipment connected to the player, track marks may be added to the positions you do not want. If that happens, change the positions of the track marks to those you want.

## Change the track marks correctly

- To erase a track mark → “Combining recorded tracks (Combine Function)” (page 39): You can combine two tracks into a single one by erasing the track mark between the two tracks.
- To add a track mark → “Dividing recorded tracks (Divide Function)” (page 37): You can divide one track into two tracks by adding a track mark.



### You can also use the following functions

- Erasing a single track → “Erasing recordings (Erase Function)” (page 34)
- Erasing all tracks on an MD → “Erasing recordings (Erase Function)” (page 35)
- Changing the order of the tracks → “Moving recorded tracks (Move Function)” (page 41)
- Locating any point in the track quickly → “Dividing recorded tracks (Divide Function)” (page 37)
- Combining several independently recorded portions into a single track → “Erasing recordings (Erase Function)” (page 34) and “Combining recorded tracks (Combine Function)” (page 39)

#### Note



After you stop recording, do not disconnect the AC power cord or move the player while “TOC EDIT” is flashing in the display. If you do so, recording may not be done properly.

# Erasing recordings

## (Erase Function)

You can quickly erase the recorded tracks or unnecessary portion in the track. Unlike a cassette-corder, blank portion will not remain after erasure.

Here are three options to erase recordings:

- Erasing a single track
- Erasing all tracks on an MD
- Erasing a portion of a track

### Notes

- If “Protected” appears in the display, the tab on the MD is in the record-protect position (page 64).

-  After you stop recording, do not disconnect the AC power cord or move the player while “TOC EDIT” is flashing in the display. If you do so, recording may not be done properly.

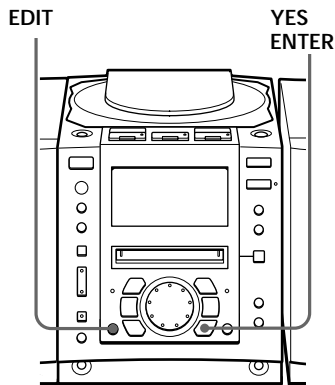

### Erasing a single track

You can erase a whole track quickly. When you erase a track, the total number of tracks on the MD decreases by one and all tracks following the erased one are renumbered.

- 1** Play the track you want to erase.
- 2** Press EDIT repeatedly until “Track Erase” appears in the display.
- 3** Press YES•ENTER.

“Erase OK?” appears in the display, and one-track repeat play starts. Once you have erased a track, you cannot recover it. Be sure to check the contents of the track you are trying to erase.

If you want to cancel the erase function at this point:

Press NO•CANCEL or MD ■.

- 4** Press YES•ENTER.

“Complete” appears in the display for a few seconds, and the current track will be erased.

Note



After you stop recording, do not disconnect the AC power cord or move the player while "TOC EDIT" is flashing in the display. If you do so, recording may not be done properly.

## Erasing all tracks on an MD

You can erase the disc name, all recorded tracks and their names at the same time. After you have erased all tracks on the MD, you can use it as a new MD.

**1** While the player is stopped, press EDIT repeatedly until "All Erase" appears in the display.

**2** Press YES•ENTER.

"Erase OK?" appears in the display. Once you have erased a track, you cannot recover it. Be sure to check the contents of the track you are trying to erase.

**If you want to cancel the erase function at this point:**

Press NO•CANCEL or MD ■.

**3** Press YES•ENTER.

After "TOC EDIT" disappears from the display, "Blank Disc" appears in the display, and all contents on the MD are erased.

continued

## Erasing recordings (Erase Function) (continued)

### Note

**TOC  
EDIT**

After you stop recording, do not disconnect the AC power cord or move the player while "TOC EDIT" is flashing in the display. If you do so, recording may not be done properly.

### Erasing a portion of a track

By using the Divide (page 37), Erase (page 34) and Combine (page 39) functions, you can erase specific portions of a track.

Example: Erasing a portion of track A

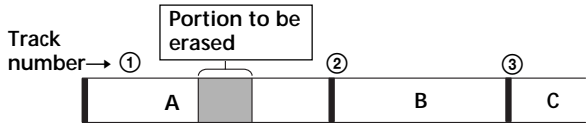

**1** Divide A into three parts (page 37).



**2** Erase A#2 (page 34).

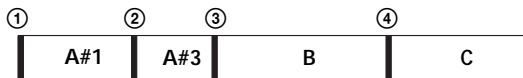

**3** Combine A#1 and A#3 (page 39).

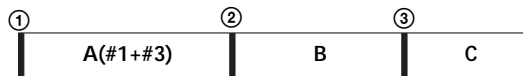

# Dividing recorded tracks

## (Divide Function)

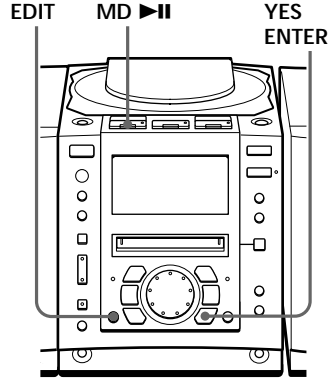

When recording from the radio, etc., track marks may not be added correctly. A number of tracks may be included in a single track. You can divide these tracks into separate tracks, and add a new track mark to each track. All tracks following the divided tracks are renumbered.

### Tips

- To put the divided tracks together, see “Combining recorded tracks” on page 39.
- To divide a track during recording, press REC at the point where you want to add the track mark.

### Note

If “Sorry” appears in the display, you cannot divide the track.

If you repeat editing on the MD, you may not be able to divide a track. This is due to the system limitations of the MD (page 65), but not caused by malfunction.

Example: Dividing track 1 into three tracks

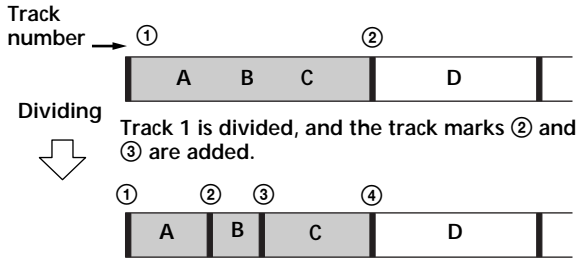

- 1 While playing the MD, press MD ►|| at the point where you want to create a new track.

The player pauses.

- 2 Press EDIT repeatedly until “Divide” appears in the display.

- 3 Press YES • ENTER.

“Divide OK?” appears in the display.

If you want to cancel the divide function at this point:

Press NO • CANCEL or MD ■.

continued

---

## Dividing recorded tracks (Divide Function) (continued)

### Note



After you stop recording, do not disconnect the AC power cord or move the player while "TOC EDIT" is flashing in the display. If you do so, recording may not be done properly.

### 4 Press YES•ENTER.

"Complete" appears in the display for a few seconds after the track is divided. The original track only has the track name, while the new track has no name (this happens only when the track you divided had its track name). One track is added to the music calendar.

# Combining recorded tracks

## (Combine Function)

You can combine two adjacent tracks into a single one. Using the combine function, you can combine a number of fragmented recordings or delete the unnecessary track marks. All tracks following the combined track are renumbered.

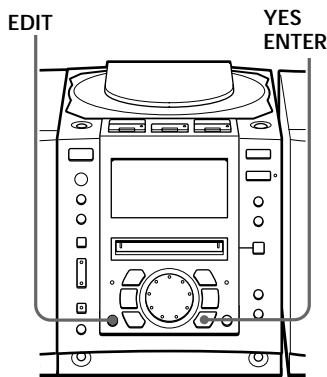

### Notes

- If “Sorry” appears in the display, you cannot combine the tracks. If you repeat editing on the MD, you may not be able to combine the tracks. This is due to the system limitations of the MD (page 65), but not caused by malfunction.
- If “Cannot Edit” appears in the display, you may be trying to combine the tracks on the first track. You cannot use the combine function on the first track.

Example: Combine the tracks B and C

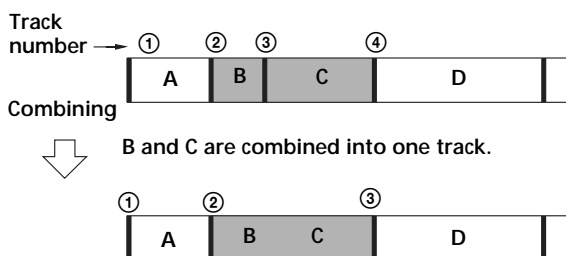

- 1** Play the track you want to combine.  
Example: To combine tracks B and C, play the track C.
- 2** Press EDIT repeatedly until “Combine” appears in the display.
- 3** Press YES•ENTER.  
“Combine OK?” appears in the display; the player enters the playback pause mode.  
If you want to cancel the combine function at this point:  
Press NO•CANCEL or MD ■.

continued

---

## Combining recorded tracks (Combine Function) (continued)

### Note

**TOC  
EDIT**

After you stop recording, do not disconnect the AC power cord or move the player while "TOC EDIT" is flashing in the display. If you do so, recording may not be done properly.

### 4 Press YES•ENTER.

"Complete" appears in the display for a few seconds after the tracks are combined. If both of the combined tracks had track names, the name of the latter track is erased. The total number of tracks in the music calendar decreases by one.



# Moving recorded tracks

(Move Function)

You can change the order of the tracks. After you move the track, the track numbers are renumbered automatically.

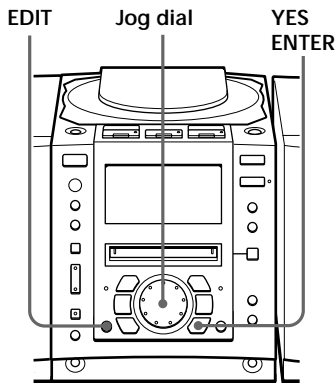

## Note



After you stop recording, do not disconnect the AC power cord or move the player while "TOC EDIT" is flashing in the display. If you do so, recording may not be done properly.

Example: Moving C to the position of track 1

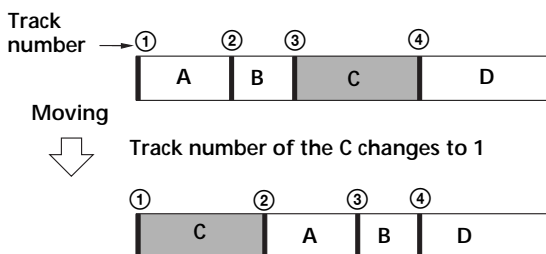

- 1 Play the track you want to move.
- 2 Press EDIT repeatedly until "Track Move" appears in the display.
- 3 Press YES•ENTER.  
"→Track 003?" appears in the display, and one-track repeat play starts.
- 4 Turn the jog dial to select the new track position.  
If you want to cancel the move function at this point:  
Press NO•CANCEL or MD ■.
- 5 Press YES•ENTER.  
"Complete" appears in the display for a few seconds after the track is moved.

# Labeling recordings

## (Name Function)

Either during recording or after recording, you can label the MDs and the tracks you have recorded with letters, numbers and symbols. You can input up to about 1,700 characters into each MD.

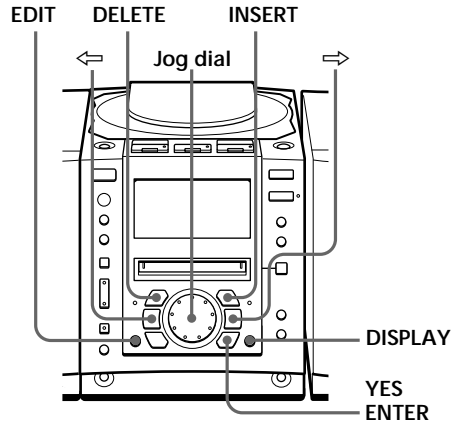

### Notes

- When recording a CD containing CD text information, a track name appears in the display at the time of labeling. Change the name according to step 3 on page 43, if necessary, then press YES•ENTER. The track names that have been labeled on a CD will not be recorded on an MD until you press YES•ENTER to confirm it.
- Certain characters contained in the CD text information (É, à, ñ, ç, ß, [, ], etc.) cannot be labeled on the MD. These characters will be labeled as blanks on the MD.

### Labeling during recording

- You can label both MDs and tracks during synchronized recording of a whole CD (page 6) or the tracks you programmed (page 27).
- You can label the tracks only during synchronized recording of a single track – REC IT (page 26).

### During synchronized recording of a whole CD or the tracks you programmed

You can label an MD or a track with up to 50 characters. You can label up to 30 tracks. If you want to label more than 30 tracks, label the tracks after recording (page 45).

- 1** During recording, press EDIT repeatedly until “Disc Name” or “Track Name” appears in the display, and press YES•ENTER.  
When you label an MD, select “Disc Name”.  
When you label a track, select “Track Name”.
- 2** When you label a track, turn the jog dial to select a track number in a CD, and press YES•ENTER.  
When you label an MD, proceed to step 3.

**The characters you can input**

- Uppercase letters:  
ABCD.....WXYZ',/:  
□ (space)
- Lowercase letters:  
abcd.....wxyz',/:  
□ (space)
- Numbers and symbols:  
0123456789!#\$%&()\*\*,;  
<=>? @ \_ ` + - ' , / :  
□ (space)

**Note**



After you stop recording, do not disconnect the AC power cord or move the player while "TOC EDIT" is flashing in the display. If you do so, recording may not be done properly.

**3** Input the characters using the jog dial.

Turn the jog dial clockwise or counterclockwise to select the character, and press ⇐⇒ to make the cursor shift rightward.

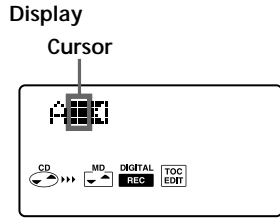

Besides the jog dial, you can use the following buttons:

Button to use	Function
DISPLAY	Each time you press the button, the character changes as follows: Uppercase letters → Lowercase letters → Numbers and symbols.
⇐, ⇒	Move the cursor leftward or rightward.
DELETE	Delete the character marked by the cursor.
INSERT	Make a space between the characters.

**4** Repeat step 3 to complete an entire name.

**5** Press YES•ENTER.

The name has been labeled on the MD.

continued

## Labeling recordings (Name function) (continued)

### Notes

- When recording a CD containing CD text information, a track name appears in the display at the time of labeling. Change the name according to step 3 on page 43, if necessary, then press YES•ENTER. The track names that have been labeled on a CD will not be recorded on an MD until you press YES•ENTER to confirm it.
- Certain characters contained in the CD text information (É, à, ñ, ç, ß, [, ], etc.) cannot be labeled on the MD. These characters will be labelled as blanks on the MD.

### During REC IT recording

You can label a track name only. You can input up to 100 characters.

- 1** During recording, press EDIT.  
The display waits for the input of the characters.
- 2** According to steps 3 and 4 on page 43, label a track.
- 3** Press YES•ENTER.  
The name is labelled on the MD.

**Tip**

When using an MD that has been already labeled, a disc name or a track name appears in the display at the time of labelling. Change the name according to step 3 on page 43, if necessary, then press YES•ENTER to confirm the new name.

**Labeling after recording**

To label an MD or a track, operate as follows. You can input up to 100 characters for each label.

- 1** When you label an MD, insert the MD you want to label and stop operation.

When you label a track, play the track you want to label.

- 2** Press EDIT repeatedly until “Disc Name” or “Track Name” appears in the display, and press YES•ENTER.

When you label an MD, select “Disc Name”.

When you label a track, select “Track Name”.

- 3** Label the MD or the track according to steps 3 and 4 on page 43.

- 4** After completing an entire name, press YES•ENTER.

The name is labelled on the MD.

**To change the name**

According to step 1 on this page, make the disc name or the track name you want to change appear in the display. Replace the old name with a new one, and press YES•ENTER.

# Setting the clock

“- -y - -m - -d” and “- :- -” indications appear in the display until you set the clock.

Once the clock is set, the recording date and time are stamped automatically (pages 7, 26 and 28).

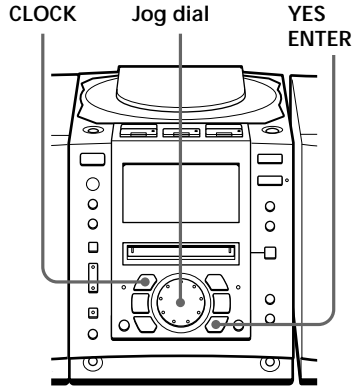

### Tips

- The time display system of this player is the 12-hour system.
- You can set the clock of this player any time, no matter whether power is on or off.

**1** Press and hold CLOCK until the year digits flash.

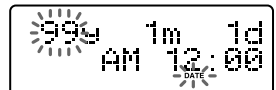

**2** Set the date.

① Turn the jog dial to set the year and press YES•ENTER.

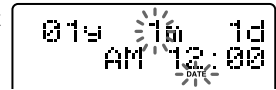

② Turn the jog dial to set the month and press YES•ENTER.

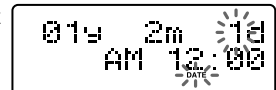

③ Turn the jog dial to set the day and press YES•ENTER.



**3** Set the time.

① Turn the jog dial to set the hour and press YES•ENTER.

② Turn the jog dial to set the minutes.

- 4** Press YES•ENTER.  
The clock starts from 00  
seconds.



01y 2m 14d  
AM 9:15

**To display the time**

Press CLOCK. To go back to the previous display, press CLOCK again. When the power is turned off, the time indication is displayed.

# Waking up to music

You can wake up to music or a radio program at a preset time.

Make sure you have set the clock (see “Setting the clock” on page 46).

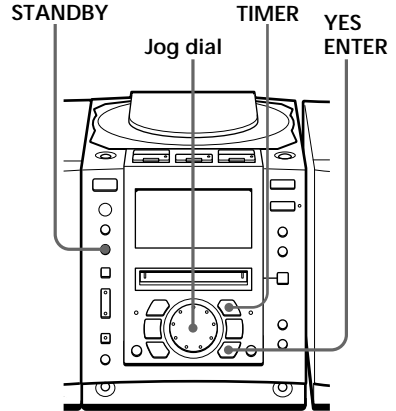

## Notes

- You cannot preset waking up timer and recording timer (page 50) at the same time.
- When playing the sound of the component connected to the LINE IN jack of the player, refer to the operating instructions of the component.

Before you begin, make sure “TIMER PLAY” or “TIMER REC” is not displayed. If either one is displayed, press STANDBY.

## 1 Prepare the music source you want to play.

Source	Do this
CD	Insert a CD.
MD	Insert an MD.
RADIO	Tune in the station.
LINE	Turn on the equipment connected to LINE IN.

## 2 Press TIMER.

“TIMER PLAY” or “TIMER REC” flashes in the display.



Make the following settings by checking the indications in the display.

## 3 Turn the jog dial until “TIMER PLAY” flashes in the display, and press YES•ENTER.

“MD”, “CD”, “RADIO” or “LINE” flashes in the display.

## 4 Turn the jog dial until the music source you want to play (“MD”, “CD”, “RADIO” or “LINE”) appears in the display, and press YES•ENTER.



**Tip**

If you made a mistake, press NO•CANCEL. The setting entered last will be cleared. Re-enter it.

**Tips**

- To exit the standby mode, press STANDBY to make “TIMER PLAY” disappear from the display.
- The preset settings remain until you reset them.
- As long as the ☹ indication appears in the display, the player is in timer mode.

- 5** Set the timer to the hour and the minutes you want the music to go on.

- ① Turn the jog dial to set the hour and press YES•ENTER.
- ② Turn the jog dial to set the minutes and press YES•ENTER.



- 6** Set the timer to the hour and the minutes you want the music to go off (Do as step 5.).

- 7** Turn the jog dial to set the volume you want, and press YES•ENTER.



- 8** Press STANDBY.

“TIMER PLAY” lights up; the player enters the standby mode.

At the preset time, the power will go on and music will play. Then the power will go off at the preset time, and the player will enter the standby mode again.

**To check/change the waking up timer settings**

Press TIMER, then press YES•ENTER. Each time you press YES•ENTER, a stored setting is displayed in the set order. To change the setting, display the setting you want to change and re-enter it.

**To use the player before a timer playback starts**

If you turn on the player, you can use it as usual (in case of the radio, if you listen to the station which is different from the one you tuned in step 1 on page 48, you will hear that station at the preset time). Turn off the player before the preset time.

**To stop play**

Turn off the power.

# Timer-recording radio programs

You can set timer to record the radio at a certain time. You can also record from the component connected to the LINE IN jack of the player.

Make sure you have set the clock (see “Setting the clock” on page 46).

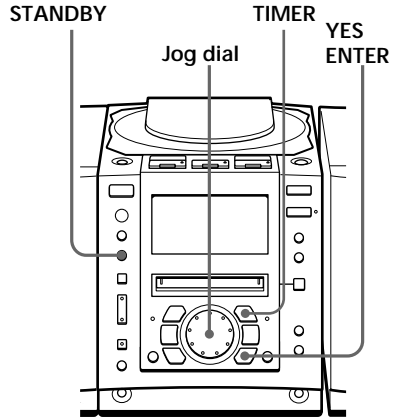

## Notes

- You cannot preset recording timer and waking up timer (page 48) at the same time.
- When recording from the component connected to the LINE IN jack of the player, refer to the operating instructions of the component.

## Tip

If you made a mistake, press NO•CANCEL. The setting entered last will be cleared. Re-enter it.

Before you begin, make sure “TIMER PLAY” or “TIMER REC” is not displayed. If either one is displayed, press STANDBY.

- 1 Tune in the radio station and insert an MD.
- 2 Press TIMER.

“TIMER PLAY” or “TIMER REC” flashes in the display.



Make the following settings by checking the indications in the display.

- 3 Turn the jog dial until “TIMER REC” flashes in the display, and press YES•ENTER.
- 4 Turn the jog dial until “RADIO” flashes in the display, and press YES•ENTER.

When recording from the component connected to the LINE IN jack of the player, turn the jog dial until “LINE” flashes in the display, and press YES•ENTER.

- 5 Set the timer to the hour and the minutes you want to start recording.

- ① Turn the jog dial to set the hour and press YES•ENTER.
- ② Turn the jog dial to set the minutes, and press YES•ENTER.



**Tips**

- To exit the standby mode, press STANDBY to make "TIMER REC" disappear from the display.
- The preset settings remain until you reset them.
- As long as the ⊖ indication appears in the display, the player is in timer mode.

**6** Set the timer to the hour and the minutes you want to stop recording. (Do as step 5.)

**7** Turn the jog dial to set the volume you want, and press YES•ENTER.

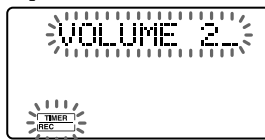

**8** Press STANDBY.

"TIMER REC" is displayed, and the player enters the standby mode.

At the preset time, the power will go on and the recording will start. Then the power will go off at the preset time, and the player will enter the standby mode again.

**To check/change the recording timer settings**

Press TIMER, then press YES•ENTER. Each time you press YES•ENTER, a stored setting is displayed in the set order. To change the setting, display the setting you want to change and re-enter it.

**To use the player before a timer-recording starts**

If you turn on the player, you can use it as usual (in case of the radio, if you listen to the station which is different from the one you tuned in step 1 on page 50, you will hear that station at the preset time). Turn off the player before the preset time.

**To stop timer-recording**

Turn off the power.

# Falling asleep to music

You can set the player to turn off automatically after 10, 20, 30, 60, 90 and 120 minutes, allowing you to fall asleep while listening to music.

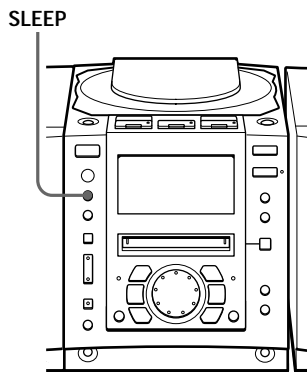

## Tips

- You can combine the waking up timer with the sleeping timer. Set the waking up timer first (page 48), turn on the player, and then set the sleeping timer.
- You can prepare the different music for the waking up timer and the sleeping timer. However, you cannot store different radio stations.
- You can set different volume for the waking up timer and the sleeping timer. For instance, you can sleep at lower volume and wake up at higher volume.

- 1 Play the music source you want.
- 2 Press SLEEP until “SLEEP” appears in the display.
- 3 Press SLEEP to select the minutes for the sleeping timer.

Each time you press the button, the indication changes as follows:

“60” → “90” → “120”  
→ no indication →  
“10” → “20” → “30”.

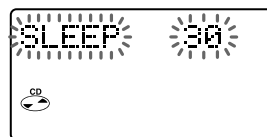

If 4 seconds have passed after you pressed SLEEP, the minutes in the display are entered.

The preset time has passed, the player goes off automatically.

## To cancel the sleep function

Press SLEEP to make “SLEEP” disappear from the display.

## To change the preset time

Do the steps 2 and 3 again.

# Hooking up the system

According to the illustrations, connect the cords firmly. Wrong connections cause malfunctions. Connect the AC power cord last.

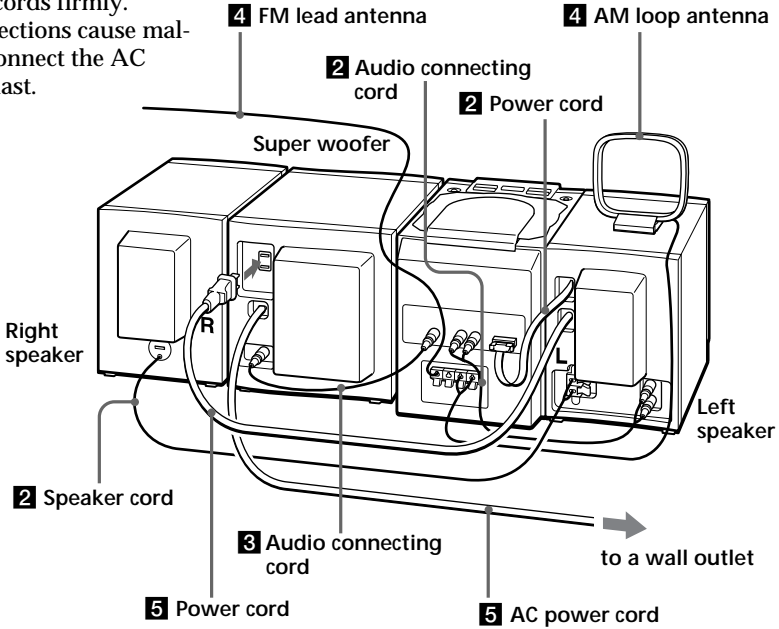

**Note**

Be sure to turn off the power of the player before connecting/disconnecting the AC power cord.

**1 Arranging the super woofer and speakers**

Leave at least a small space between the player, super woofer, and speakers. If you do not do this, vibration from the super woofer may cause the sound to skip.

continued

## Hooking up the system (continued)

### Note

Connect the supplied speakers to this player. If you connect any other speakers or equipment, a malfunction may occur.

### 2 Hooking up the speakers

- 1 Connect the power cord of the POWER OUTPUT on the left speaker to the POWER INPUT jack of the player.

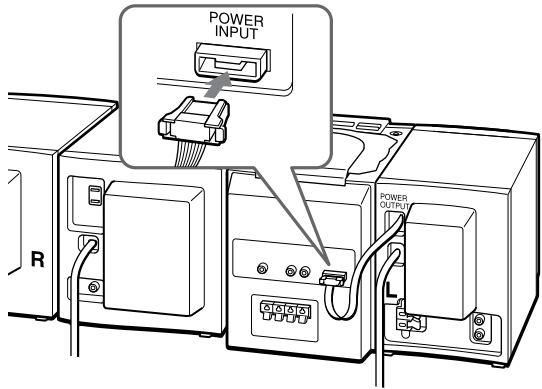

- 2 Connect the audio connecting cord (supplied) to the SIGNAL OUTPUT jacks of the player and the SIGNAL INPUT jacks of the left speaker.

Connect the white plugs to the L (left) jacks and the red plugs to the R (right) jacks.

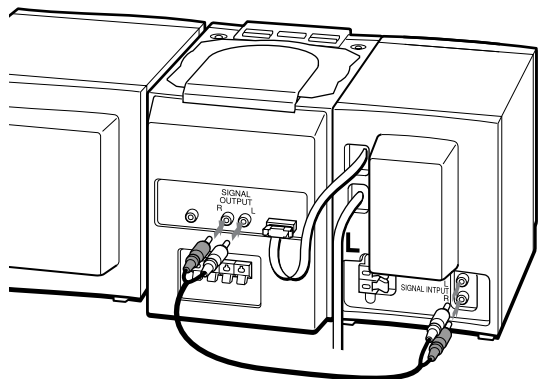

- 3** Connect the speaker cord of the right speaker to the SPEAKER OUT terminals of the left speaker.
- ① Push open the tab of the terminal.
  - ② Connect the red wire to the (+) plus terminal, and the black wire to the (-) minus terminal.
  - ③ Push the tab of the terminal back.

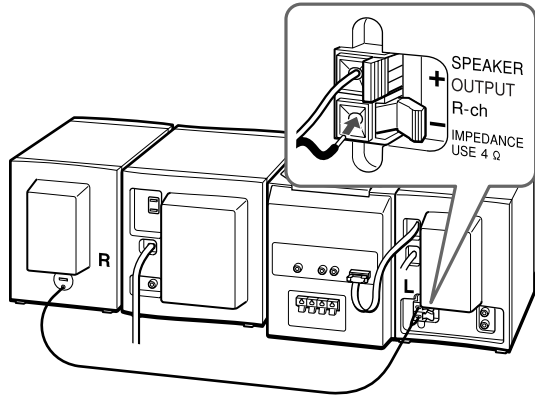

### 3 Hooking up the super woofer

Connect the audio connecting cord (supplied) to the SIGNAL OUTPUT (WOOFER) jack of the player and the SIGNAL INPUT (WOOFER) jack of the super woofer.

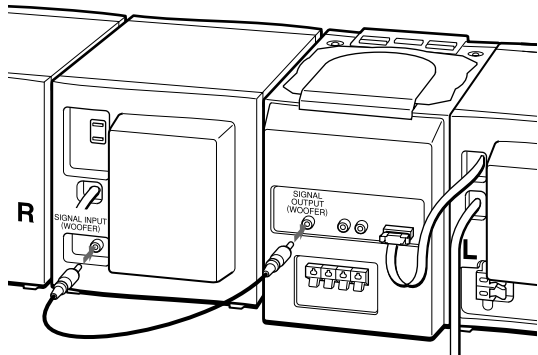

continued

## Hooking up the system (continued)

### Note

Keep the AM loop antenna away as far as possible from the player. If you do not, noise may be heard.

## 4 Hooking up the antennas

- 1 Strip the coating from the end of the cable and twist the wires.

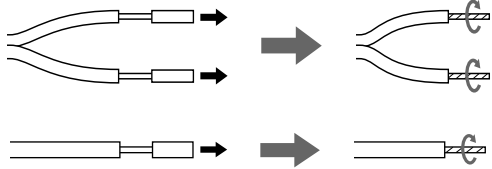

- 2 Connect the wires of the AM loop antenna and the FM lead antenna to the terminals.

- ① Press and hold the tab of the terminal.
- ② Connect the wires to the terminal.
- ③ Release the tab of the terminal.

AM loop antenna\*  
(supplied)

FM lead antenna\*\*  
(supplied)

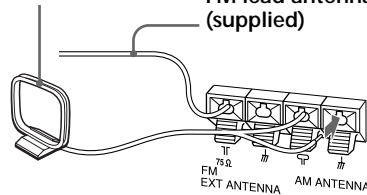

\*Reorient the antenna to improve broadcast reception.

\*\*Keep the antenna as horizontal as possible.

## Setting up the AM loop antenna

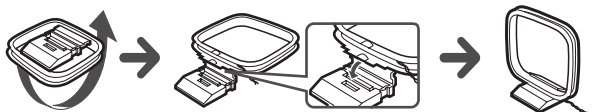



**Tip**

The sound quality may be changed depending on the polarity of the AC power cord plug. Change the direction of inserting the plug and check the sound quality.

**5** Connecting the AC power cord

Connect the power cord of the left speaker to the AC OUTLET MAX 35 W jack of the super woofer.

Then, connect the AC power cord of the super woofer to the wall outlet.

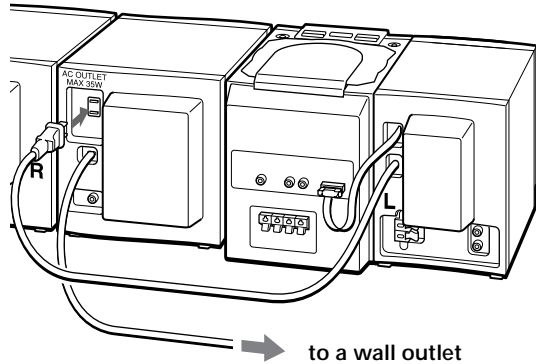
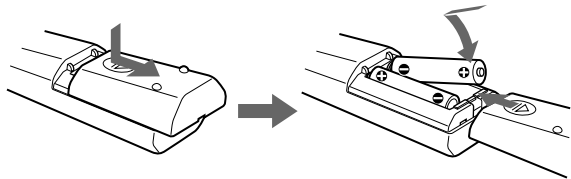
**6** Inserting batteries into the remote

Insert two size AA (R6) batteries (not supplied)

**Replacing batteries**

With normal use, the batteries should last for about six months. When the remote no longer operates the player, replace all the batteries with new ones.

continued

## Hooking up the system (continued)

### Important

When you use an outdoor antenna, be sure to connect the  $\#$  terminal to earth against lightning. To prevent a gas explosion, do not connect the ground wire to a gas pipe.

### To improve the FM reception

Connect the FM outdoor antenna (not supplied). If you use a distributor, you can also use the TV antenna.

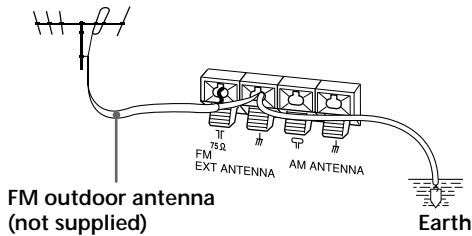

### To improve the AM reception

Connect a 6- to 15-meter (20- to 50 feet) insulated wire (not supplied) to the AM ANTENNA terminal. Keep the wire as horizontal as possible near the window or outdoor. You do not need to disconnect the supplied AM loop antenna.

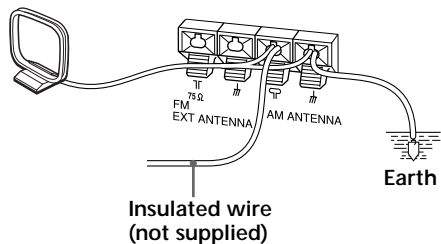

# Connecting optional components

You can enjoy the sound from a TV or VCR through the speakers of this player.

Be sure to turn off the power of each component before making connections. For details, refer to the instructions of the component to be connected.

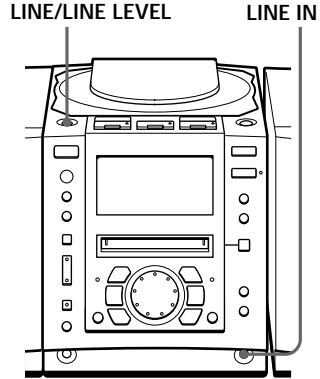

## Note

Connect the cords firmly to avoid any malfunction.

## Connecting a TV or a VCR

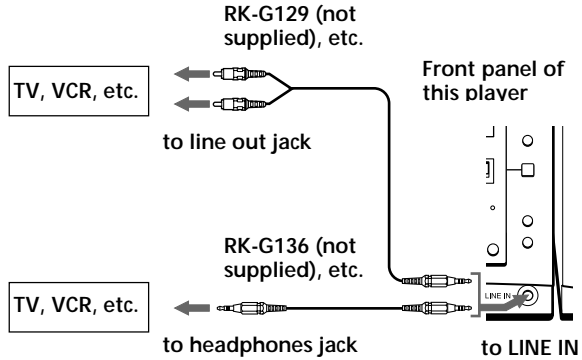

After finishing the connections, turn on the player, and press LINE/LINE LEVEL on the top panel repeatedly to display "LINE".

continued

---

## Connecting optional components (continued)

### Tip

If there is no sound input for more than 2 seconds during recording, a track mark is stamped automatically.

### Recording the sound from the connected components

- 1 Insert a recordable MD.
- 2 Press LINE/LINE LEVEL on the top panel to display “LINE”.
- 3 Press REC.  
The player stands by for recording.
- 4 Press MD ►||.  
Recording starts.
- 5 Play the optional component connected to the LINE IN jack of the player.

### If the volume of the component connected to the LINE IN jack is too high

Press LINE/LINE LEVEL to display “Level: High” (“Level: Normal” under the normal conditions ) or reduce the volume of the connected component.

# Using the super woofer

You can enjoy bass-boosted sound using the supplied super woofer.

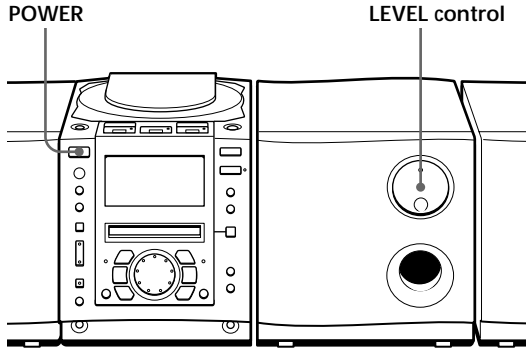

## Tip

When adjusting the bass level, use a piece of music you listen to often. A piece with a strong bass line, such as music which features a bass guitar is also suitable for level adjustment.

## Adjusting the woofer level

- 1** Press **POWER** to turn on the player.  
The power of the super woofer turns on automatically.
- 2** Play your favorite music at your usual volume setting.
- 3** Adjust the bass level of the super woofer using the **LEVEL** control.  
Turn the control clockwise little by little to increase the bass sound. Adjust the bass level to your personal preference.

Once you have adjusted the bass level to match your music, you do not have to make any further adjustments. The volume of the super woofer will change accordingly as you adjust the **VOL** (volume) control of the player.

# Adjusting the audio emphasis

You can adjust the audio emphasis of the bass sound or the bass/treble sound you are listening to.

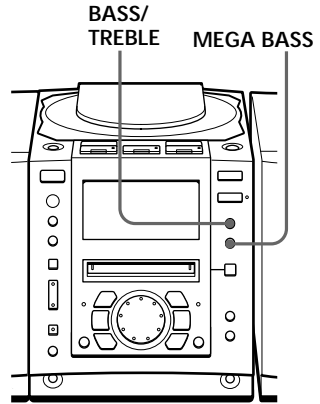

## Reinforcing the bass sound

Press MEGA BASS until “MEGA BASS On” appears in the display.

Display



### On the remote

- 1 Press BASS/TREBLE.
- 2 Adjust the sound using + or - button.

### Note

When the volume is too high, the sound adjustments may not be effective.

## Adjusting the bass/treble sound

- 1 Press BASS/TREBLE until “BASS” or “TREBLE” appears in the display.
- 2 Adjust the bass or treble sound using the jog dial.

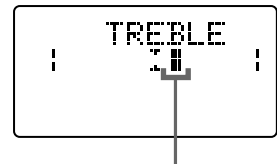

As you turn the jog dial, the cursor moves left or right. As the cursor moves rightward, the level will be turned up. As the cursor moves leftward, the level will be turned down.

# Precautions

## On safety

- As the laser beam used in the CD and MD player section is harmful to the eyes, do not attempt to disassemble the casing. Refer servicing to qualified personnel only.
- Should any solid object or liquid fall into the player, unplug the player, and have it checked by qualified personnel before operating it any further.

## On power sources

- The player is not disconnected from the AC power source (mains) as long as it is connected to the wall outlet, even if the player itself has been turned off.
- Unplug the player from the wall outlet when it is not to be used for an extended period of time.
- When the batteries are not to be used, remove them to avoid damage that can be caused by battery leakage or corrosion.
- The nameplate indicating operating voltage, power consumption, etc. is located on the right side.

## On placement

- Do not leave the player in a location near heat sources, or in a place subject to direct sunlight, excessive dust or mechanical shock.
- Do not place anything within 10 mm of the side of the cabinet. The ventilation holes must be unobstructed for the player to operate properly and prolong the life of its components.

- If the player is left in a car parked in the sun, be sure to choose a location in the car where the player will not be subjected to the direct rays of the sun.
- Since a strong magnet is used for the speakers, keep personal credit cards using magnetic coding or spring-wound watches away from the player to prevent possible damage from the magnet.

## On operation

- If the player is brought directly from a cold to a warm location, or is placed in a very damp room, moisture may condense on the lenses inside the CD and MD player section. Should this occur, the player will not operate properly. In this case, remove the CD or MD and wait about an hour for the moisture to evaporate.

If you have any questions or problems concerning your player, please consult your nearest Sony dealer.

continued

## Precautions (continued)

### Notes on CDs

- Before playing, clean the CD with a cleaning cloth. Wipe the CD from the centre out.



- Do not use solvents such as benzene, thinner, commercially available cleaners or anti-static spray intended for vinyl LPs.
- Do not expose the CD to direct sunlight or heat sources such as hot air ducts, nor leave it in a car parked in direct sunlight as there can be a considerable rise in temperature inside the car.
- Do not stick paper or sticker on the CD, nor scratch the surface of the CD.
- After playing, store the CD in its case.

If there is a scratch, dirt or fingerprints on the CD, it may cause tracking error.

### Cleaning the lens

If the lens becomes dirty, it may cause a skipping of sound during CD operation. Clean with a commercially available blower.

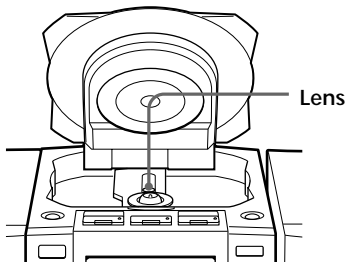

### Cleaning the cabinet

Clean the cabinet, panel and controls with a soft cloth slightly moistened with a mild detergent solution. Do not use any type of abrasive pad, scouring powder, or solvent, such as alcohol or benzene.

### Notes on MDs

- Do not open the shutter to expose the MD. Close the shutter immediately if the shutter opens.



Shutter Cartridge

- Wipe the disc cartridge with a dry cloth to remove dirt.

### Protecting a recorded MD

To record-protect an MD, slide open the tab at the side of the MD (so the tab is concealed).

In this position, the MD cannot be recorded. To record on the MD, slide close the tab.

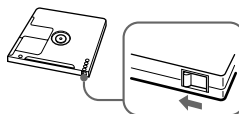

Slide open the tab.



---

# System limitations of the MD

The recording system in your MiniDisc recorder is radically different from those used in cassette and DAT decks and the system has limitations described below. Note, however, that these limitations are due to the inherent nature of the MD recording system itself and not to mechanical causes.

**"Disc Full" appears in the display even before the MD has reached the maximum recording time (60 or 74 minutes).**

When 254 tracks have been recorded on the MD, "Disc Full" appears regardless of the total recorded time. More than 254 tracks cannot be recorded on the MD. To continue recording, erase unnecessary tracks.

**"Disc Full" appears in the display even before the MD has reached the maximum track number or recording time.**

Repeated recording and erasing may cause fragmentation and scattering of data. Although those scattered data can be read, each fragment is counted as a track. In this case, the number of tracks may reach 254 and further recording is not possible. To continue recording, erase unnecessary tracks.

**The remaining recording time does not increase even after erasing numerous short tracks.**

Tracks under 12 seconds long are not counted, so erasing them may not increase the recording time.

**Some tracks cannot be combined with others.**

Track combination may become impossible when tracks are under 12 seconds long.

**The total recorded time and the remaining time on the MD may not reach the maximum recording time (60 or 74 minutes).**

Recording is done in minimum units of 2 seconds each, no matter how short the material. The contents recorded may thus be shorter than the maximum recording capacity. Disc space may also be further reduced by scratches.

**The sound may dropout while fast-forwarding or rewinding the edited tracks.**

Tracks created through editing may exhibit sound dropout during fast-forwarding or rewinding because high-speed playback takes time to search for the position on the disc when the tracks are scattered on the disc.

continued

---

---

## System limitations of the MD (continued)

### Guide to the serial copy management system

Digital audio equipment such as CDs, MDs, DATs, etc., copy music easily with high quality, for these products process music as a digital signal. The Serial Copy Management System allows you to make only a single copy of a recorded digital source through digital-to-digital connections because music programmes may be copyrighted.

This system is applied to this player.

### You can make only a first-generation copy\* through a digital-to-digital connection.

That is :

- 1 You can make a copy of a digital sound programme on the market such as CDs, MDs, etc., but you cannot make a second copy from the first-generation copy.
- 2 You can make a copy of a digital signal from a digitally-recorded analog sound programme on the market such as an analog record, music cassette tape, etc., or from digital satellite broadcasts, but you cannot make a second copy.

#### Note

No restrictions apply when a digital signal is recorded as an analog signal (that is, when a digital signal is recorded through analog-to-analog connection).

- \* A first-generation copy is a digital recording of a digital signal made on digital audio equipment through a digital-to-digital connection.  
During recording, "DIGITAL REC" appears in the display on this player.

---

# Getting to know the MD

## Structure

The 2.5-inch MiniDisc (MD) is compact and easy to handle requiring less care as it is encased in a plastic cartridge that looks like a 3.5-inch diskette (see illustrations below).

## Parts making up a MiniDisc

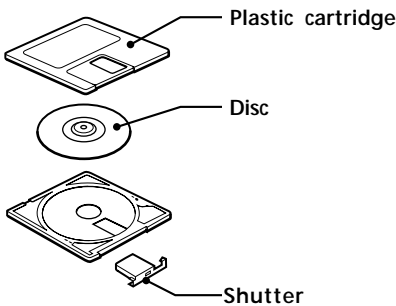

## Disc variation

MDs come in two types: pre-mastered (pre-recorded) and recordable (blank). Pre-mastered MDs cannot be recorded on or over like cassette tapes. To record, you must use a “recordable MD.”

## Pre-mastered MDs

Pre-mastered MDs are recorded and played like regular CDs. A laser beam focus on the pits on the surface of the MD and reflects the information back to the lens in the recorder. The recorder then decodes the signals and plays them back as music.



## Recordable MDs

Recordable MDs, which use magneto-optical (MO) technology, can be recorded again and again. The laser inside the recorder applies heat to the MD, demagnetizing the magnetic layer of the MD. The recorder then applies a magnetic field to the layer. This magnetic field corresponds exactly to the audio signals generated by the connected source. (The north and south polarities equate to digital “1” and “0.”) The demagnetised MD adopts the polarity of the magnetic field, resulting in a recorded MD.



continued

---

## Getting to know the MD (continued)

### Features

#### Long recording

The MD uses a new digital audio compression technology called Adaptive Transform Acoustic Coding (ATRAC). To store more sound in less space, ATRAC extracts and encodes only those frequency components actually audible to the human ear.

#### Quick random access

Like CDs, MDs offer instantaneous random access to the beginning of any music track. Pre-mastered MDs are recorded with location addresses corresponding to each music track.

#### Shock-resistant memory

One major drawback of optical read systems is that they skip or mute the sound when subject to vibration. The MD system resolves this problem by using a buffer memory that stores audio data.

# Troubleshooting

	Symptom	Remedy
General	There is no audio.	<ul style="list-style-type: none"> <li>• Press POWER to turn on the player.</li> <li>• Connect the AC power cord to a wall outlet securely.</li> <li>• Connect the power cord to POWER INPUT of the player (page 54).</li> <li>• Connect the audio connecting cord correctly (page 54).</li> <li>• Adjust the volume.</li> <li>• Unplug the headphones from the <math>\odot</math> jack when listening through speakers.</li> <li>• Wait until "TOC Reading" disappears from the display.</li> </ul>
	The picture of your TV becomes unstable.	<ul style="list-style-type: none"> <li>• Move the player away from the TV.</li> </ul>
	Noise is heard	<ul style="list-style-type: none"> <li>• Someone is using a portable telephone or other equipment that emits radio waves near the player. → Move the portable telephone, etc., away from the player.</li> </ul>
CD Player	The CD does not play./"No Disc" lights in the display even when a CD is in place.	<ul style="list-style-type: none"> <li>• Make sure that the CD compartment is closed.</li> <li>• Place the CD with the label surface up.</li> <li>• Clean the CD.</li> <li>• Take out the CD and leave the CD compartment open for about an hour to dry moisture condensation.</li> </ul>
	The sound drops out.	<ul style="list-style-type: none"> <li>• Reduce the volume.</li> <li>• Clean the CD, or replace it if the CD is badly damaged.</li> <li>• Place the player in a location free from vibration.</li> </ul>
MD Player	An incompletely inserted MD cannot be pulled out.	<ul style="list-style-type: none"> <li>• The MD player's self-lock system has gripped the MD. Insert the MD completely, then press <math>\blacktriangle</math> MD EJECT.</li> </ul>
	"Disc Error" lights in the display and the player does not operate.	<ul style="list-style-type: none"> <li>• Take the MD out and insert it again. If "Disc Error" remains, replace the MD. Try erasing all tracks on the MD (page 35).</li> </ul>

continued

## Troubleshooting (continued)

	Symptom	Remedy
MD Player	The MD does not play.	<ul style="list-style-type: none"> <li>Take out the MD and leave the player in a warm place for several hours until the moisture evaporates.</li> <li>The MD is inserted in the wrong direction. Slide the MD into the disc compartment with the label side up and the arrow pointing towards the opening until the player grips it.</li> <li>The MD may be blank (the music calendar does not appear). Replace the disc with one that has been recorded.</li> </ul>
	The MD does not record.	<ul style="list-style-type: none"> <li>The MD is record-protected ("Protected" appears). Close the record-protect slot.</li> <li>The track has been protected using another MD recorder ("Trk Protect" appears). Release the track-protect on the same MD recorder that protected the track.</li> <li>The player is not connected properly to the sound source. Make connections properly to the sound source.</li> <li>A pre-mastered MD is inserted. Replace it with a recordable MD.</li> <li>There is not enough space left on the MD. Replace it with another recordable MD with enough space, or erase unnecessary tracks.</li> <li>There has been a power failure. The mains lead has been disconnected. Data recorded to that point may be lost. Repeat the recording procedure.</li> </ul>
	The recorded sound drops out.	<ul style="list-style-type: none"> <li>The sound was recorded at high volume. Record again at lower volume.</li> </ul>
Radio	A stereo program cannot be received in stereo.	<ul style="list-style-type: none"> <li>Press MONO/ST until "Stereo" appears in the display (page 11).</li> </ul>
	The audio is weak or has poor quality.	<ul style="list-style-type: none"> <li>The FM stereo broadcast may be noisy (page 11).</li> <li>Move the player away from the TV.</li> <li>If you are using the remote while listening to an AM radio, noise may be heard. This is unavoidable.</li> <li>Move the AM loop antenna away from the player.</li> </ul>

	Symptom	Remedy
Timer	The timer does not operate.	<ul style="list-style-type: none"> <li>• Make sure the time on the clock is correct.</li> <li>• Check to see if the AC power had been cut off.</li> <li>• Make sure "TIMER REC" or "TIMER PLAY" appears in the display.</li> <li>• Check and change the preset start/stop time if both times are set to the same time.</li> </ul>
	The remote does not function.	<ul style="list-style-type: none"> <li>• Replace all the batteries in the remote with new ones if they are weak (page 57).</li> <li>• Make sure that you are pointing the remote at the remote sensor on the player.</li> <li>• Remove any obstacles in the path of the remote and the player.</li> <li>• Make sure the remote sensor is not exposed to strong light such as direct sunlight or fluorescent lamp light.</li> <li>• Move closer to the player when using the remote.</li> </ul>

Operation may become unstable depending on the power supply or other causes because this player employs a microcomputer to link each operation. If other troubles not described above occur, disconnect the AC power cord from the wall outlet, then connect it again after about 20 seconds. If the problem still occurs, press the RESET button at the bottom of the player with a pointed object (In this case, clock set, timer or preset radio stations are reset to the initial settings. Set these items again if you need). If the problem persists, please consult your nearest Sony dealer.

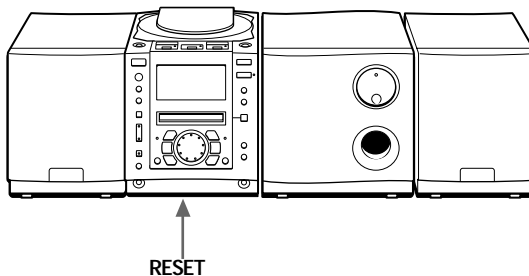

---

# Error messages

If the player cannot perform an MD or a CD operation, one of the following error messages may flash in the display window.

This message will flash	If
Blank Disc	you try to play an MD with no recording on it.
Cannot Edit	you try to use the combine function on the first track of the MD.
Disc Error	you inserted a damaged MD or an MD missing a TOC (information on recording contents).
Disc Full	there is no more space for recording or editing on the MD. (See "System limitations of the MD" on page 65.)
Name Full	the labelling capacity of the MD has reached its limit. Each label can be made up of up to 100 characters. You can input up to about, 1,700 characters into each MD.
No Disc	you try to play or record with no CD or MD in the player.
No MD	you try to play or record with no MD in the player (in case of synchronized recording, etc.).
PB Disc	you try to record or edit on a pre-mastered MD (PB means playback).
Protected	you try to record or edit on an MD with the tab in the record-protect position.
Sorry	you try to edit, ignoring the system limitations of the MD.
Trk Protect	you try to record or edit a track that has been already protected using other MD recorders.
No Text	you have selected the track that has no text information when playing a CD containing CD text information.



---

# Specifications

## AUDIOPOWER SPECIFICATIONS

### POWER OUTPUT AND TOTAL HARMONIC DISTORTION

With 4-ohm loads, both channels driven from 100 - 10,000 Hz; rated 7 W per channel - minimum RMS power, with no more than 10 % total harmonic distortion in AC operation.

Super woofer with 4-ohm loads, driven at 70 Hz; rated 30 W minimum RMS power, with no more than 10 % total harmonic distortion in AC operation.

## Other Specifications

### CD player section

#### System

Compact disc digital audio system

#### Laser diode properties

Material: GaAlAs

Wave length: 785 nm

Emission duration: Continuous

Laser output: Less than 44.6  $\mu$ W

(This output is the value measured at a distance of about 200 mm from the objective lens surface on the optical pick-up block with 7 mm aperture.)

#### Spindle speed

200 r/min (rpm) to 500 r/min (rpm) (CLV)

#### Number of programme positions

2

#### Frequency response

20 - 20,000 Hz +1/-1 dB

#### Wow and flutter

Below measurable limit

### Radio section

#### Frequency range

FM: 87.6 - 108 MHz

AM: 530 - 1,710 kHz

#### Antennas

FM: Lead antenna

AM: Loop antenna

### MD player section

#### System

Minidisc digital audio system

#### Disc

MiniDisc

#### Laser diode properties

Material: GaAlAs

Wave length: 785 nm

Emission duration: Continuous

Laser output: Less than 44.6  $\mu$ W

(This output is the value measured at a distance of about 200 mm from the objective lens surface on the optical pick-up block with 7 mm aperture.)

#### Recording/playback time

Maximum 74 minutes (with MDW-74)

#### Revolutions

400 rpm to 900 rpm (CLV)

#### Error correction

Advanced Cross Interleave Reed Solomon Code (ACIRC)

#### Sampling frequency

44.1 kHz

#### Coding

Adaptive TTransform Acoustic Coding (ATRAC)

#### Modulation system

EFM (Eight-to-Fourteen Modulation)

#### Number of programme positions

2 stereo programme positions

#### Frequency response

20 - 20,000 Hz +1/-2 dB

#### Signal-to-noise ratio

Over 80 dB (during playback)

#### Wow and flutter

Below measurable limit

### Super woofer

#### Speaker

Woofer: 10 cm (4 in.) dia., 4.0 ohms, cone type

#### Power output

30 W (at 100 Hz)

#### Power consumption

AC 28 W

#### Dimensions (incl. projecting parts)

Approx. 172 × 181 × 231 mm (w/h/d)

(6  $\frac{7}{8}$  × 7  $\frac{1}{4}$  × 9  $\frac{1}{8}$  inches)

#### Mass

Approx. 3.6 kg (7 lb. 15 oz.)

**continued**

---

## Specifications (continued)

### General

#### Speaker

Full-range : 8 cm (3 in.) dia., 4 ohms cone type (2)

#### Inputs

LINE IN (stereo minijack): Sensitivity 436 mV/  
870 mV

#### Outputs

Headphones jack (stereo minijack) (1):

For 32 ohms impedance headphones

#### Power requirements

For personal minidisc system:

120 V AC, 60 Hz

For remote controller:

3 V DC, 2 size AA (R6) batteries

#### Power consumption

34 W

#### Dimensions (incl. projecting parts)

Player: approx. 152 × 189 × 235 mm (w/h/d)  
(6 × 7 ½ × 9 ¾ inches)

Left speaker: approx. 139 × 181 × 235 mm  
(w/h/d) (5 ½ × 7 ¼ × 9 ¾ inches)

Right speaker: approx. 139 × 181 × 235 mm  
(w/h/d) (5 ½ × 7 ¼ × 9 ¾ inches)

#### Mass

Player: approx. 2.9 kg (6 lb. 6 oz.)

Left speaker: approx. 2.8 kg (6 lb. 3 oz.)

Right speaker: approx. 1.4 kg (3 lb. 1 oz.)

#### Supplied accessories

Remote controller (1)

FM lead antenna (1)

AM loop antenna (1)

Audio connecting cord (2)

### Optional accessories

Sony MDR headphone series

U.S. and foreign patents licensed from Dolby  
Laboratories Licensing Corporation.

Design and specifications are subject to change without  
notice.

---

# Index

## A

- Adjusting
  - bass 62
  - treble 62
  - volume 5, 9, 11
- ATRAC 68
- AUTO PRESET 23

## B

- Batteries
  - for the remote controller 57

## C

- CD player 12
- Checking playing time
  - a CD 12
  - an MD 14
- Cleaning 64
- Clock 46
- Combine function 39
- Connecting
  - AC power cord 57
  - antenna 56, 58
  - optional components 59
  - super woofer 61
  - the system. *See* Hooking up the system
- Creating your own program 20

## D

- Display 12 - 15
- Divide function 37

## E, F

- Editing 32
- Erase function 34
- Error message 72

## G

- Getting to know the MD 67

## H

- HIGH SPEED 7,26
- Hook up
  - antennas 56, 58
  - speakers 54
  - super woofer 55
  - system 53

## I, J, K

- Improving broadcast reception 11

## L

- Listening to the radio 10
- Locating a specific point on a track 18
- Locating a specific track 18

## M

- MD player 12
- MEGA BASS 62
- Move function 41

## N, O

- Name function 42

## P, Q

- Playing
  - a CD 4
  - an MD 8
  - preset radio stations 25
  - tracks repeatedly 19
- Power sources 57
- Presetting radio stations 23
- Program Play 20

## R

- Radio stations
  - playing 10
  - presetting 23
- Recording
  - a CD 6, 30
  - on an MD 6, 30, 31
- Repeat Play 19

## S

- Serial copy management system 66
- Setting up 53
- Shuffle play 22
- Super woofer 55, 61
- System limitations 65

## T

- Text information on a CD 16
- Timer
  - playback 48
  - recording 50
- Troubleshooting 69

## U, V, W, X, Y, Z

- Using
  - the display 12 - 15

